



Politechnika  
Wrocławska

- Praca doktorska prezentowana w celu
- uzyskania tytułu doktora nauk technicznych
- 
- Dyscyplina : Inżynieria Środowiska
- Prezentowana przez : Mateusz Słupiński ■
- 
- 

**Tytuł**  
«Metoda analizy złożonego systemu na  
przykładzie strategii produkcji energii w  
elektrociepłowni »

« The method for analysis of the complex system : Application to the strategy  
of the energy production in the heat and power co-generation plant »

Praca pisana w ramach umowy o wspólnym dyplomowaniu  
i prowadzeniu pracy doktorskiej pomiędzy Politechniką  
Wrocławską i Uniwersytetem Ludwika Pasteur'a w Strasbourgu ■

## **Członkowie rady :** ■

<b>Promotor :</b>	<b>Janusz Jeżowiecki, Prof, Politechnika Wrocławska</b>
<b>Współpromotor :</b>	<b>Roland de Guio, Prof, INSA de Strasbourg</b>
<b>Recenzent wewnętrzny PWr :</b>	<b>Sergey Anisimov, Prof, Politechnika Wrocławska</b>
<b>Recenzent zewnętrzny PWr :</b>	<b>Henryk Foit, dr hab., Politechnika Śląska</b>
<b>Recenzent zewnętrzny :</b>	<b>Emmanuel Caillaud, Prof, Université Louis Pasteur, Strasbourg</b>
<b>Recenzent zewnętrzny :</b>	<b>Aline Cauvin, dr hab., Laboratoire des Sciences de l'Information et des Systèmes, Marsylia</b>

Thèse présentée pour obtenir le grade de  
Docteur de l'Université Louis Pasteur  
Strasbourg I

- 
- 
- 
- 
- 
- 
- 

Discipline : Sciences de l'ingénieur  
par Mateusz Słupiński ■

Titre

*« Méthode d'analyse de système complexe :  
Application à la stratégie de production d'énergie  
dans les centrales co-génératrices de chaleur et  
d'électricité »*

« The method for analysis of the complex system : Application to the strategy  
of the energy production in the heat and power co-generation plant »

Cotutelle de thèse entre Université de Technologie  
de Wrocław et Université Louis Pasteur Strasbourg I ■

## Membres du jury: ■

Directeur de Thèse : M. Roland de Guio, Prof.,  
INSA de Strasbourg

Co-Directeur de Thèse : M. Janusz Jeżowiecki, Prof.,  
Université de Technologie de Wrocław

Rapporteur Interne ULP : M. Emmanuel Caillaud, Prof,  
Université Louis Pasteur, Strasbourg

Rapporteur Externe ULP : Mme. Aline Cauvin, HDR,  
Laboratoire des Sciences de l'Information et des  
Systèmes, Marseille

Rapporteur Externe : M. Sergey Anisimov, Prof,  
Université de Technologie de Wrocław

Rapporteur Externe : M. Henryk Foit, HDR, Université de Technologie de  
Silésie, Gliwice

## Acknowledgments

I would like to thank all people who helped me and have supported me during the PhD studies and research. First of all I would like to thank my mentor in Poland, Prof. Janusz Jeżowiecki, for the warm welcome at the Wrocław University of Technology and the support during the whole period of PhD studies. I would like to thank my mentor in France Prof. Roland de Guio from INSA Strasbourg - Graduate School of Science and Technology, for the great support and for making possible the cooperation in the frame of the co-mentorship convention. The maintenance of the close contact with LGECO would not be possible without consultations of the research with Mr. Dmitry Kucharavy, my tutor at INSA Strasbourg, thank you very much. Great thanks to Dr Pawel Malinowski from Wrocław University of Technology, for introducing me to the field of energy market, district heating and heat & power co-production plants. For the support in the engineering details concerning the process of preparation of the energy production strategy, I would like to thank Mr. Max Scheidt, CEO of ProCom GmbH Aachen, Ms Ebbecke Sinje and Mr. Christian Tegler consultants from ProCom. I would like to thank also to all people working at LGECO for the great and welcoming atmosphere during my stay in France.

## The title - translations

In English:

« The method for analysis of the complex system : Application to the strategy of the energy production in the heat and power co-generation plant »

In French:

« Méthode d'analyse de système complexe : Application à la stratégie de production d'énergie dans les centrales co-génératrices de chaleur et d'électricité »

In Polish:

« Metoda analizy złożonego systemu na przykładzie strategii produkcji energii w elektrociepłowni »

## Keywords

Keywords: complex system, system analysis approach, problem solving approach, energy production strategy, urban energy production system

Mots clés: système complexe, approche d'analyse de système, approche de solution des problèmes, stratégie de production de l'énergie, system de production de l'énergie pour la zone urbaine

Słowa kluczowe: system złożony, podejście do analizy systemu, podejście do rozwiązywania problemów, strategia produkcji energii, system produkcji energii dla aglomeracji miejskiej

## The thesis was prepared at:

1. Chair of Heating and Air Conditioning  
Department of Environmental Engineering  
Wroclaw University of Technology  
Ul. Norwida 4/6 bud. C-6  
50-373 Wrocław  
Poland
  
2. LGECO - Design Engineering Laboratory  
INSA Strasbourg - Graduate School of Science and Technology  
24 boulevard de la Victoire  
67084 Strasbourg CEDEX  
France

---

## Résumé

---

The research presented in the thesis addresses the problem in approach to the analysis of complex systems. The practical example, used as a case to develop the method of analysis, is the problem in the system of the process for preparation of the energy production strategy in the energy generation system for the urban area. The analysis of this complex system, which includes many systems from different domains, can be approached in two general ways. One is to use a ready to apply method of analysis. Second is to construct a method from the separate analysis tools assembled to match the particularities of the analyzed case. The second approach has been chosen as a one which will benefit from the united advantages of the particular analysis tools. The important problem in the creation of the method was the coordination of the various analysis tools in order to apply them in the most efficient way and organize the obtained results. This task has been realized by the systematic use of the tools for information management. Application of the analysis tools providing the control over the analysis process helped to bind the entire analysis and distinct three key foundations of the method: exploration tools, guidance tools and information management tools. Proposed solution in the construction of the method contributed in two main areas: the methodology of the analysis of the system of problem and the comprehension of the problems appearing in the complex system of problem based on the physical system of the preparation process of the energy production strategy.



---

Résumé  
Version in French

---

---

## Résumé de thèse

---

Le problème pratique support de la thèse concerne l'optimisation de la stratégie de production journalière d'énergie électrique et thermique urbaine de la société GENCO. Le support informatique au processus d'optimisation en place à savoir le logiciel BoFiT TEP (Daily Operation Optimization and Portfolio Management) permet de construire un modèle simulant le fonctionnement du réseau de centrales. Le résultat du processus de décision est un scénario de production obtenu par un processus itératif. Pour initier le processus, un expert propose un scénario à partir de données liées au marché. Les caractéristiques des scénarios de production sont fournies au logiciel BoFiT TEP qui dans un premier temps les transforme en un problème d'optimisation de type mixed integer problem (MIP) dont le but est de trouver la combinaison de ressources du réseau à faire fonctionner au moindre coût et dans les contraintes du scénario. L'optimisation est ensuite réalisée par un outil standard CPLEX. L'expert analyse ensuite le résultat pour le valider ou proposer un nouveau scénario. Le processus se poursuit dans un temps limité (1h) et une décision est prise par l'expert. Les temps de calcul sont considérés comme trop long car ils ne permettent pas à l'expert de réaliser suffisamment d'itérations. Les temps de calcul augmentent avec le nombre d'éléments de détails mis dans le modèle. Le problème initial peut être exprimé sous la forme d'une contradiction : nous voulons avoir beaucoup d'éléments dans le modèle afin d'améliorer la stratégie de production (maximisation du bénéfice pour GENCO), et en même temps nous ne voulons pas avoir pas beaucoup d'éléments dans le modèle parce que la consommation de temps du processus de calcul augmente avec le volume de données à traiter.

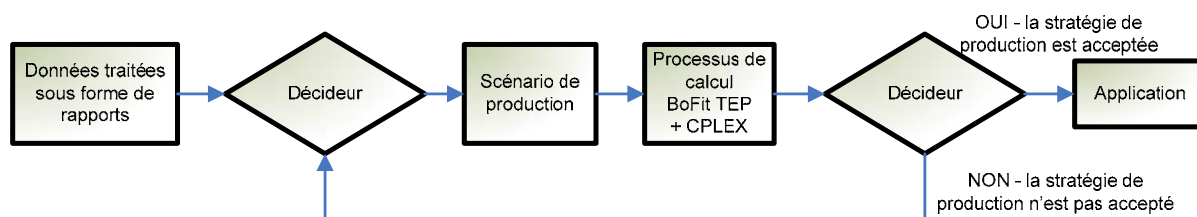

Figure 1. Processus de production de scénario

La compréhension approfondie du système de production de scénarios en vue de son optimisation n'est pas immédiate pour plusieurs raisons :

- Le nombre de variables à traiter est important et évolue dans le temps,
- Le processus de préparation des scénarios relève de connaissances de plusieurs domaines, le marché et les statistiques, les divers modèles de production d'énergie, des processus de calcul.



- Certaines activités du processus, notamment la production de scénarios et leur validation, relèvent de connaissances implicites. En fait, l'interface entre les modèles cités précédemment n'est pas formalisée.

Pour les raisons évoquées précédemment, une perception de l'influence des différents systèmes composant le processus de production de scénarios sur son optimisation s'avère nécessaire. L'un des objectifs de cette thèse est de proposer une démarche et des outils permettant d'identifier les problèmes clés liés à l'évolution du processus de production des scénarios et de donner une vision de leurs liens, d'aider à la prise de décision quant aux tactiques de résolution et, enfin, de mettre en forme cet ensemble de problèmes dans un formalisme permettant l'utilisation itérative d'outils et de méthodes de résolution de problèmes inventifs. Ce dernier point est nécessaires dans notre cas, car l'optimisation individuelle des éléments du système de production de scénario ne permettra pas de satisfaire les performances attendues à terme du système ; il faudra donc modifier le modèle du système, en inventer un nouveau qui résoudra des contradictions inhérentes au système existant.

En principe, différents outils et méthodes générales sont disponibles pour atteindre les résultats escomptés cités dans le paragraphe précédent. Deux approches s'opposent pour l'exploitation de ces outils. La première consiste à choisir un outil générique d'analyse de notre système et de l'adapter au problème traité. La seconde approche, que nous avons choisie, est de combiner des méthodes existantes pour tirer profit des valeurs ajoutées de leurs différences. La difficulté lors de l'emploi de cette tactique est de combiner à bon escient et de contrôler l'extraction de l'information utile au traitement de notre problème spécifique. En effet, d'une part les informations issues de ces méthodes se recouvrent partiellement et, d'autre part, les informations de différentes natures issues de ces méthodes sont à mettre en cohérence. Le second objectif de cette thèse est d'apporter une contribution méthodologique aux démarches générales d'analyse de systèmes complexes en vue de la résolution des contradictions associées à leur évolution (i.e : les résultats de l'analyse doivent permettre l'utilisation des méthodes de résolution de problème issues des théories de résolution des problèmes inventifs). En terme de conception de méthode, le conflit à résoudre est résumé sur la figure 2 ci-dessous.

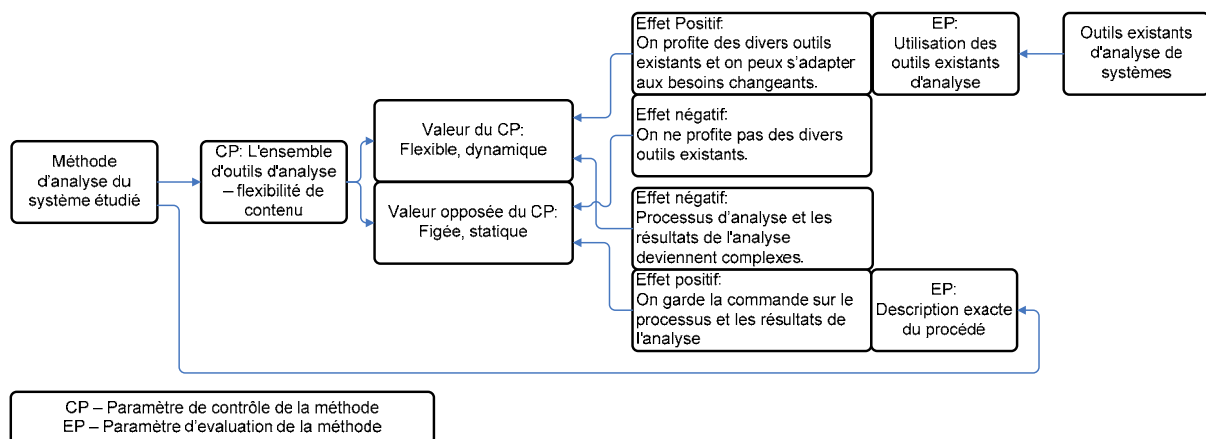

Figure 2: Contradiction associée à la construction de la méthode d'analyse

La méthode proposée en résultat de nos travaux repose sur la maîtrise et le contrôle des différents outils utilisés à partir d'une classification en trois familles:

- Les outils d'exploration qui permettent de décrire et d'explorer le système étudié,
- Les outils permettant d'orienter et de guider vers les étapes suivantes,

- Les outils de gestion de l'information et d'évaluation.

Le mémoire se compose de 6 chapitres. Le chapitre 1 décrit les approches connues d'analyse des systèmes complexes et formule le problème méthodologique abordé dans cette étude. Le chapitre 2 présente le système de préparation et de validation de scénarios de production d'énergie. Le chapitre 3 présente la catégorisation des outils d'analyse utilisés pour le traitement du cas d'étude. Le chapitre 4 aborde l'utilisation d'outils d'analyse proposés sur le cas de la génération d'une stratégie de production. Le chapitre 5 présente la méthode proposée. La conclusion et les perspectives du travail sont présentées dans le chapitre 6.

#### Chapitre 1. Portée et buts

L'introduction présente en détail les propriétés de quelques approches de résolution de problème et d'analyse de système complexe (théorie des agents, théorie des systèmes dynamiques, etc.). Les caractéristiques principales d'un système complexe sont présentées sur l'exemple des systèmes traités en ingénierie de l'environnement. La comparaison des approches existantes et des caractéristiques des systèmes complexes est employée pour formuler le but et la portée de notre recherche.

#### Chapitre 2. Le système de préparation de la stratégie journalière de production

Le système de préparation des stratégies de production journalière est introduit dans ce chapitre. Le système est décrit de plusieurs points de vue : sa position dans l'environnement, le processus de prise de décision.

L'utilisation du modèle technologique et des scénarios par le logiciel BoFiT TEP sont également présentés.

#### Chapitre 3. Outils d'analyse - introduction

Les outils d'analyse utilisés sont classés dans les catégories suivantes : des théories, des méthodes, des techniques, des procédures, des règles, des modèles et des concepts. Des outils d'analyse appliqués dans le chapitre suivant sont classés selon la description de l'objectif et du domaine d'application.

#### Chapitre 4. Analyse du problème de préparation de scénarios

L'analyse du problème de la préparation de la génération d'énergie débute par l'application d'outils simples permettant de collecter l'information de base sur le système. Ce type d'outils est appelé par la suite « outils d'exploration ». Ces outils sont complétés par des outils d'organisation des résultats de l'analyse.

#### Chapitre 5. Synthèse et généralisation : l'approche proposée

La construction de cette approche a été effectuée pendant lors de l'analyse du système de préparation des scénarios. La méthode d'analyse peut elle aussi être considérée comme un système d'activités. L'analyse de ce système montre qu'il lui manque un système de contrôle. Ce système de contrôle de l'analyse est porté sur trois points : l'exploration du système, une aide à l'orientation des activités suivantes, et enfin la gestion des informations. Le rôle du système de contrôle est de combiner judicieusement et d'aligner les méthodes existantes au cas particulier traité. Ainsi les outils existants utilisés lors d'une étude ne sont pas connus au départ de l'application de la méthode.

## Chapitre 6. Conclusion et perspectives

La méthode proposée permet de tirer parti de l'utilisation de plusieurs méthodes sans en avoir les inconvénients pratiques grâce au système de contrôle de l'information. Cette approche permet de construire en temps réel la démarche adaptée à un système donné.

Cette approche a permis dans le cas de la préparation des stratégies journalières de production d'énergie d'améliorer la communication avec les experts de divers domaines, d'avoir une compréhension globale et partagée entre experts des problèmes clés, et enfin d'avoir une meilleure compréhension des sous problèmes.



---

Résumé  
Version in Polish

---

---

## Streszczenie

---

Problem praktyczny, na którym zbudowana jest praca dotyczy optymalizacji dobowej strategii produkcji energii elektrycznej i ciepłej dla aglomeracji miejskiej. Jako wsparcie informatyczne dla procesu optymalizacji zastosowane jest oprogramowanie BoFiT TEP (Daily Operation Optimization and Portfolio Management), pozwalające skonstruować model symulujący funkcjonowanie sieci jednostek wytwarzających energię. Wynikiem procesu decyzyjnego jest scenariusz produkcji otrzymany w wyniku procesu iteracyjnego. W celu zainicjowania procesu, ekspert proponuje scenariusz na podstawie danych związanych z rynkiem energii. Charakterystyki scenariuszy produkcji są umieszczane w oprogramowaniu BoFiT TEP, który w pierwszym etapie zamienia je na problem optymalizacyjny typu mixed integer problem (MIP, problem o zmiennych całkowitych, mieszanych). Celem jest znalezienie takiej kombinacji środków dostępnych w sieci, aby układ produkował najtańszą energię w ramach ograniczeń zawartych w scenariuszu. Optymalizacja jest następnie realizowana przez standardowe narzędzie CPLEX. Następnie ekspert analizuje wyniki w celu ich zaakceptowania lub propozycji nowego scenariusza. Proces odbywa się w ograniczonym czasie (ok. 1h), a decyzja jest podejmowana przez eksperta. Czasy obliczeń zostały uznane za zbyt długie ponieważ nie pozwalają ekspertowi na realizację wystarczającej liczby iteracji. Czas obliczeń wzrasta z liczbą szczegółowych elementów umieszczonych w modelu. Wstępny problem może zostać wyrażony w formie sprzeczności: chcemy mieć wiele elementów w modelu aby polepszyć strategię produkcji (maksymalizacja zysku dla GENCO), i jednocześnie nie chcemy mieć wielu elementów w modelu ponieważ zużycie czasu poprzez proces obliczeniowy rośnie wraz z objętością obrabianych danych.

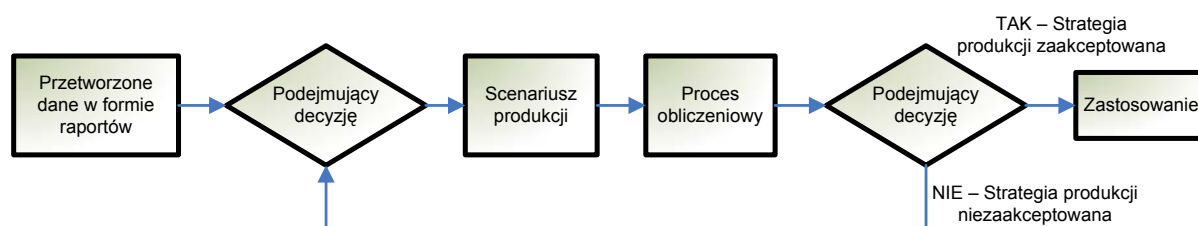

Figure 2. Proces tworzenia scenariusza

Dogłębne zrozumienie systemu przygotowania scenariuszy w celu jego optymalizacji nie jest od razu możliwe z paru powodów :

- Liczba zmiennych do przerobienia jest znacząca i ewoluuje w czasie,
- Proces przygotowania scenariuszy zależy od znajomości wielu dziedzin, rynku i statystyki, różnych modeli produkcji energii, procesów obliczeniowych.
- Niektóre składowe procesy, szczególnie przygotowanie scenariusza i jego walidacja, wymagają szczegółowej wiedzy. W zasadzie, interface pomiędzy modelami wspomnianymi wcześniej nie jest sformalizowany.

Z przyczyn wymienionych wcześniej, staje się konieczne rozpoznanie wpływu różnych systemów składowych procesu produkcji scenariuszy na jego optymalizację. Jednym z celów tej pracy doktorskiej jest zaproponowanie procedury i narzędzi pozwalających na zidentyfikowanie kluczowych problemów powiązanych z ewolucją procesu produkcji scenariuszy i dostarczenie obrazu jego powiązań, w celu pomocy w podjęciu decyzji, a także taktyki rozwiązania i ostatecznie, w celu ukształtowania tej całości problemów w formę pozwalającą na iteracyjne korzystanie narzędzi i metody rozwiązywania problemów innowacyjnych. Ten ostatni punkt jest konieczny w naszym przypadku, ponieważ indywidualna optymalizacja elementów systemu produkcji scenariuszy nie pozwala na uzyskanie zadawalającej wydajności oczekiwanej z punktu widzenia systemu ; należy stąd zmodyfikować model systemu, poprzez wymyślenie nowego, który rozwiąże wrodzone sprzeczność istniejącego systemu.

W zasadzie, dostępne są różne narzędzia i metody ogólne w celu osiągnięcia oczekiwanych rezultatów wymienionych w poprzednim paragrafie. Istnieją dwa podejścia, przeciwstawiające się sobie, przy wykorzystaniu tych narzędzi. Pierwsze polega na wybraniu ogólnego narzędzia analizy naszego systemu i dostosowania go do traktowanego problemu. Drugie podejście, które zostało przez nas wybrane, to złożenie istniejących metod w celu uzyskania dodatkowej wartości z ich zróżnicowania. Trudnością w czasie zastosowania tej taktyki jest złożenie ich w dobry sposób i kontrolowanie uzyskiwania informacji użytecznych w pracy nad naszym specyficznym problemem. W rezultacie, z jednej strony część informacji uzyskanych dzięki tym metodom częściowo, wzajemnie się pokrywa, z drugiej strony, uzyskane z tych metod informacje w różnej postaci, są spójne. Drugim celem pracy doktorskiej jest dostarczenie wkładu metodologicznego w ogólnym przebiegu analizy systemów złożonych z rozwiązaniem sprzeczności powiązanych z ich ewolucją (tj. wyniki analizy powinny pozwolić na używanie metod rozwiązywania problemów pochodzących z teorii innowacyjnego rozwiązywania problemów). Na poziomie koncepcji metody, konflikt do rozwiązania jest podsumowany na rysunku 2 poniżej.

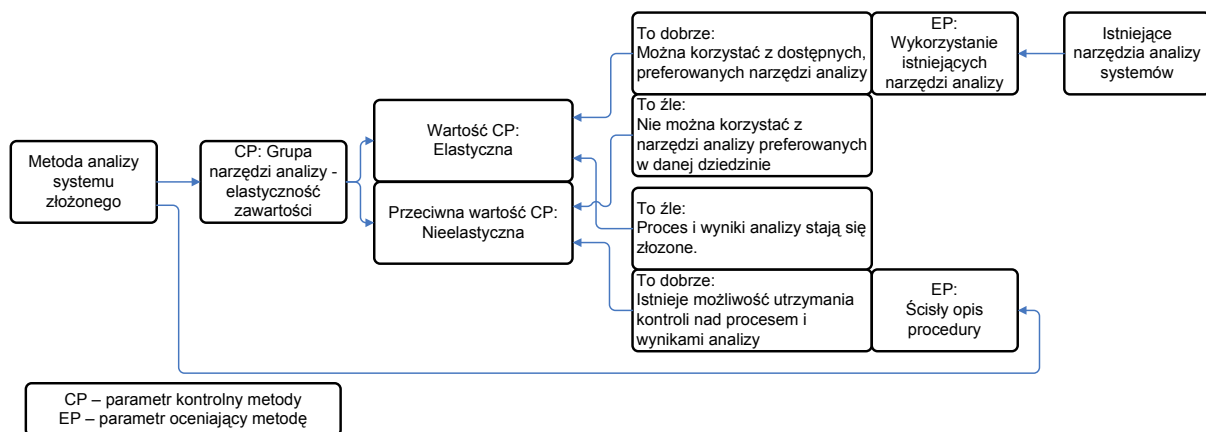

Rysunek 2: Sprzeczność powiązana z konstrukcją metody analizy

Metoda zaproponowana jako wynik naszej pracy opiera się na starannym zastosowaniu i kontroli różnych zastosowanych narzędzi sklasyfikowanych w trzech rodzinach:

- Narzędzia do eksploracji, które pozwalają na opisanie i eksplorowanie studiowanego systemu,
- Narzędzia pozwalające ukierunkować i poprowadzić do następnych etapów,
- Narzędzia zarządzania i ewaluacji informacji.

Praca składa się z 6 rozdziałów. Rozdział 1 opisuje znane podejścia do analizy systemów złożonych i formułuje problem w metodologii podjęty w tej pracy. Rozdział 2 prezentuje system przygotowania i walidacji scenariuszy produkcji energii. Rozdział 3 przedstawia kategoryzację narzędzi analizy zastosowanych do pracy nad przykładem. Rozdział 4 podejmuje tematykę stosowania narzędzi analizy zaproponowanych do przykładu procesu przygotowania strategii produkcji. Rozdział 5 prezentuje proponowaną metodę. Podsumowanie i perspektywy przyszłej pracy są zaprezentowane w rozdziale 6.

## Rozdział 1. Cel i zakres

Wprowadzenie prezentuje szczegółowo właściwości niektórych podejść do rozwiązywania problemów i analizy systemów złożonych (teoria agentów, teoria dynamiki systemów, itd.). Kluczowe cechy systemu złożonego są zaprezentowane na przykładzie systemu z dziedziny inżynierii środowiska. Porównanie istniejących podejść i charakterystyki systemów złożonych zostało wykorzystane do sformułowania celu i zakresu naszych badań naukowych.

## Rozdział 2. System przygotowania dobowej strategii produkcji

Ten rozdział zawiera wprowadzenie do systemu przygotowania dobowej strategii produkcji. System jest opisany z wielu punktów widzenia: umiejscowienia w otoczeniu, procesu podejmowania decyzji.

W tym samym rozdziale zaprezentowane jest także model technologii i przygotowania scenariuszy w oprogramowaniu BoFiT TEP.

## Rozdział 3. Narzędzia analizy – wprowadzenie

Wykorzystane narzędzia analizy są sklasyfikowane w następujące kategorie: teorie, metody, techniki, procedury, reguły, modele i koncepcje. Narzędzia analizy stosowane w następnym rozdziale są sklasyfikowane wg celu i miejsca zastosowania.

## Rozdział 4. Analiza problemu przygotowania scenariuszy

Analiza problemu przygotowania strategii produkcji energii rozpoczyna się od zastosowania prostych narzędzi pozwalających na zebranie podstawowych informacji o systemie. Ten typ narzędzi jest dalej nazywany ‘narzędziami do eksploracji’. Narzędzia te są uzupełnione narzędziami organizującymi wyniki i proces analizy.

## Rozdział 5. Synteza i podsumowanie : zaproponowane podejście

Konstrukcja przedstawionego podejścia została zrealizowana podczas analizy systemu przygotowania scenariuszy. Metoda analizy może być także uważana jako system poszczególnych działań. Analiza tego systemu wykazuje brak systemu kontroli. System kontroli analizy jest oparty na trzech punktach: eksploracji systemu, wsparciu w ukierunkowaniu dalszych kroków i ostatecznie zarządzaniu informacjami. Zadaniem systemu kontroli jest rozsądne złożenie i uporządkowanie istniejących metod do konkretnego przykładu poddanego analizie. Stąd istniejące narzędzia wykorzystane w czasie analizy przykładu nie są określone na początku wdrażania metody.

## Rozdział 6. Wnioski i perspektywy

Zaproponowana metoda pozwala na wykorzystanie wielu metod bez niekorzystnych efektów praktycznych dzięki systemowi kontroli informacji. To podejście pozwala na skonstruowanie w czasie rzeczywistym podejścia dostosowanego do zadanego systemu.



W zakresie przygotowania dobowej strategii produkcji energii, zaproponowane podejście pozwoliło na ulepszenie komunikacji z ekspertami różnych dziedzin, zrozumienia całościowego i rozdzielonego pomiędzy ekspertów w problemach kluczowych i ostatecznie uzyskanie najlepszego zrozumienia pod-problemów.



---

# Outline

---

Acknowledgments .....	5
Keywords .....	5
Résumé .....	7
Résumé de thèse .....	10
Streszczenie .....	16
Outline .....	21
List of Figures .....	24
General introduction.....	27
Reading guide.....	28
Chapter 1. Scope and aim .....	31
1. Definitions.....	31
2. Problem and system – model of problem.....	33
3. Complex problems in environmental science and practice – Classification.....	35
3.1. General properties of systems in the Environmental Engineering (EE): .....	37
3.2. Classification of problems in Environmental Engineering (EE).....	37
4. Engineering problem, complex system for analysis.....	38
5. Needs.....	39
6. Problem solving concepts, processes and tools.....	40
6.1. Agents theory .....	41
6.2. System dynamics.....	42
6.3. Evolutionary design.....	43
6.4. Theory of constraints.....	44
6.5. KJ method .....	45
6.6. C-K theory.....	46
6.7. IDEFØ .....	47
6.8. OTSM-TRIZ.....	49
6.9. Synthesis.....	51
7. System of problem – the model.....	51
8. System evolution analysis .....	53
9. Synthesis of our PhD problem issues .....	54
9.1. Scope .....	54
9.2. Aim.....	55
Chapter 2. The complex system presentation – energy generation system including CHP plant .....	57
1. Main information about power and heat generation .....	57
2. Presentation of the engineering system.....	58
2.1. From general view to the urban energy generation system.....	58
2.2. How does it work together? .....	59
2.3. Characteristic of the units applied in the system - example.....	63
2.4. Synthesis.....	63

3.	Energy market particular solutions .....	64
4.	Junction of the interests (UCED) .....	65
5.	Dealing with the problem – solutions in computation and market .....	65
5.1.	Before energy market liberalization .....	66
5.2.	After energy market liberalization .....	67
5.3.	Solution in the computation algorithms .....	68
5.4.	Solution in the market organization .....	68
5.5.	Synthesis.....	69
6.	BoFiT – example procedure incorporation .....	70
6.1.	BoFit TEP – The structure .....	71
6.2.	Components used in the model .....	73
6.3.	BoFiT – setup of an element in the model .....	75
6.4.	BoFiT – constraints .....	76
6.5.	Synthesis – information about BoFiT .....	76
7.	Operation of the model in BoFiT .....	77
Chapter 3.	Analysis tools – classification .....	79
1.	Classification of analysis tools – introduction .....	80
2.	Classification – conclusion.....	81
3.	Classification of analysis tools and the field of application.....	82
4.	Synthesis.....	85
Chapter 4.	Construction of the method .....	87
1.	Initial problem – engineering system .....	87
1.1.	Initial problem presentation .....	87
1.1.1	Initial problem – high time consumption .....	88
1.1.2	Number of data.....	89
1.1.3	Knowledge capitalization.....	90
1.1.4	Synthesis.....	93
1.2.	Problem exploration – ARIZ Part 1 .....	94
1.2.1	Contradictions .....	94
1.2.2	Introduction of process’s schemes .....	96
1.2.3	Position of the CHP in the urban energy generation system.....	98
1.2.4	The process of the production strategy preparation – BoFiT procedure.....	99
1.2.5	Knowledge capitalization .....	102
1.2.6	Synthesis.....	104
1.3.	Laws of technical system evolution .....	105
1.4.	AIS .....	106
1.5.	ARIZ – step back.....	107
1.6.	Bottleneck.....	110
1.7.	Additional features of the system observed during the analysis .....	111
1.8.	Synthesis.....	113
2.	Organization of problems, partial solutions, relations .....	114
2.1.	Multi Screen of the research.....	114
2.2.	Problem dynamics with System Dynamics .....	114
2.3.	IDEFØ of the analysis process .....	116
2.4.	Network of problems, Network of contradictions,.....	118
2.4.1	Selection of the key problems .....	119
2.4.2	Change of key problems into the contradictions.....	120
2.4.3	Selection of the key contradiction.....	121
2.4.4	Quick check of the key contradiction selection .....	122
2.4.5	Synthesis – construction of the network of contradictions .....	123

2.5. Synthesis.....	124
3. Description of the system.....	124
3.1. Input, output of the system elements.....	124
3.2. Subsystem of the data collection.....	127
3.3. Subsystem of decision making.....	128
3.4. The subsystem of scenario computation.....	131
3.5. The summary of systems and sub-systems.....	132
4. Strengths and weaknesses in the application of analysis tools.....	133
Chapter 5. Synthesis and generalization: proposed approach.....	135
1. New approach.....	135
2. Utilization of the method.....	137
3. Validation.....	139
Chapter 6. Conclusion and perspectives.....	143
References.....	147
Appendix 1. AIS - Analysis of initial situation.....	152
1. By-pass approach.....	152
1.1. Super-system.....	153
1.2. Sub-system.....	153
1.3. Opposite action.....	153
2. Which problem, original or by-pass, makes the most sense to solve?.....	154
3. Use operator STC (Size, Time, Cost).....	155
3.1. Change dimension of the object gradually from given value to infinity.....	155
3.2. Change dimension of the object from its giving value to zero.....	155
3.3. Changing the time of the process from its given value to infinity.....	156
3.4. Changing the time of the process from its given value to zero.....	156
3.5. Changing the cost (resources) from its given value to infinity.....	156
3.6. Changing the cost (resources) from its given value to zero.....	156
Appendix 2. SWOT.....	158
Appendix 3. ....	162
Appendix 4. Network of problems.....	164

---

## List of Figures

---

Figure 1.	Processus de production de scenario.....	10
Figure 2.	Proces tworzenia scenariusza.....	16
Figure 3.	The reading guide for the thesis.....	28
Figure 4.	Transformation from the problem to the solution – problem solving process.....	34
Figure 5.	Relation between physical system and the system of problem.....	34
Figure 6.	System of problem – paradigms, models of the system.....	35
Figure 7.	The design square (Hatchuel, Le Masson et al. 2004).....	46
Figure 8.	Contradiction: a) Elements of the model, b) Example (MIP – Mixed Integer Problem, PSt – Production strategy, PSt is a result of the optimization of the MIP).....	49
Figure 9.	Contradiction – many and few information (CP- control parameter).....	52
Figure 10.	System-model of the problem.....	53
Figure 11.	Causal loops presenting the method creation.....	55
Figure 12.	Position and main relations of the CHP in the urban energy generation system (day ahead market conditions).....	58
Figure 13.	Energy generation system from the point of view of the system of the preparation of the energy production strategy.....	60
Figure 14.	Synergy (Values of energy generation efficiency according to The Polish National Energy Conservation Agency).....	61
Figure 15.	Energy production in the CHP plant – production process with example elements (DH- district heating).....	62
Figure 16.	The feasible solution set for electric power and steam flow output. Condensing extraction turbine – set of operations modes. Operation at two different hot water outlet temperature levels is shown. The solid line represents a lower temperature level then the dotted line. (Thorin, Brand et al. 2001).....	63
Figure 17.	BoFiT – relation between engines.....	71
Figure 18.	Creation of the model (model with data for current situation).....	72
Figure 19.	Example of the graphical symbols used in the model in BoFiT TEP made by ProCom (ProCom 2005).....	73
Figure 20.	A view on the top level of the model in BoFiT TEP.....	75

Figure 21.	Relation between method, technique and module.....	82
Figure 22.	Time of computation – contradiction.....	88
Figure 23.	Number of constraints – contradiction.....	89
Figure 24.	Multi Screen Scheme of Inventive Thinking – description of the concept (Altshuller 1988).....	90
Figure 25.	Multi Screen Scheme of Inventive Thinking (System operator) – time consumption load and data amount.....	91
Figure 26.	IDEFØ concept – model of the function box.....	91
Figure 27.	IDEFØ scheme – Function: ‘Scenario computation’.....	92
Figure 28.	CLD Number of the data – Archetype: Limit to Success.....	92
Figure 29.	Network of problems – fragment.....	93
Figure 30.	Contradiction – Number of parameters.....	95
Figure 31.	Contradiction: Computation time.....	95
Figure 32.	Contradiction: Computation result’s precision.....	95
Figure 33.	Contradiction: Amount of data.....	96
Figure 34.	Structure of the calculation process.....	96
Figure 35.	Database transformation.....	96
Figure 36.	Data processing.....	97
Figure 37.	Data amount – contradiction I.....	97
Figure 38.	Data amount – contradiction II.....	98
Figure 39.	Urban energy system.....	98
Figure 40.	Production strategy preparation process in BoFiT (one day ahead); Explanation: ISO Independent System Operator; Duration of the computation stage is split into stages see Table 8 on page 90. ....	100
Figure 41.	Production strategy preparation process in BoFiT (after the trading session); Explanation: SCADA Supervisory Control And Data Acquisition, ISO Independent System Operator.....	100
Figure 42.	Multi Screen Scheme – Preparation of the PSt.....	103
Figure 43.	Causal Loop Diagram (CLD) – Quality of the PSt.....	103
Figure 44.	Network of problems – Energy production principle.....	104
Figure 45.	Energy flow in the system - model.....	105
Figure 46.	Decision maker (DM) and computation process.....	111
Figure 47.	Contradiction: Synergy effects.....	112
Figure 48.	Contradiction: Dynamicity.....	113
Figure 49.	Causal Loop Diagram – Decision Maker, Archetype: Fixes that fail.....	115

Figure 50.	Causal Loop Diagram – Method Development, Archetype: Shifting the burden 116	
Figure 51.	IDEFØ scheme of the production strategy preparation process.....	117
Figure 52.	IDEFØ of the research – main structure, system analysis path of research...	117
Figure 53.	IDEFØ of the research – defining the problem in the physical system.....	118
Figure 54.	Network of problems – Key problem (marked by dashed frame line).....	122
Figure 55.	Network of contradictions – objective: utilization of the record of system’s operation in order to improve the production strategy .....	123
Figure 56.	Data collection element - subsystems .....	127
Figure 57.	Decision making process – preparation of production scenario nr n .....	128
Figure 58.	Planning and forecasting (Scott Armstrong 1983).....	130
Figure 59.	Position of the DM – data flow diagram .....	130
Figure 60.	The computation process decomposed into stages (The numbers correspond to the Table 16)	132
Figure 61.	Causal Loop Diagram (CLD): Utilization of various analysis tools; Archetype: Fixes that fails	135
Figure 62.	Marginal cost curve .....	154
Figure 63.	Time of optimization, exponential dependence .....	155
Figure 64.	Network of problems - map .....	164
Figure 65.	Network of problems – page ‘Main’ .....	165
Figure 66.	Network of problems; Page 2 .....	166
Figure 67.	Network of problems; Page 3 .....	167
Figure 68.	Network of problems; Page 4.....	168
Figure 69.	Network of problems; Page 5 .....	169



---

## General introduction

---

The initial problem is located in the complex physical system of the process of preparation of the energy production strategy. The energy production strategy is prepared for the urban energy generation system operated inboard of the one energy generation company (GENCO). The physical system operated by GENCO is simplified in the shape of the model, built and operated by the software, in our case it is the BoFiT TEP (Daily Operation Optimization and Portfolio Management). The decision making process expresses its results in the form of the production scenario. Using BoFiT TEP, production scenario is put into the model in the form of mixed integer problem (MIP) and optimized by the CPLEX optimization algorithms. Decision is made again to accept the results of the optimization in the form of production strategy or to reformulate the production scenario and run the process again. The initial problem was stated as the too high time consumption in the computation process of the model.

The understanding of the physical system of the production strategy preparation faces several problems. The physical system can be characterized by the high number of elements, relations, dynamical changes of parameters and systems, included into the main system, which belong to different domains of engineering e.g.: technology process of energy production, decision making process including human elements, energy trading process, computation algorithms.

The point in the analysis of the system of problem, created on the basis of the physical system of the production strategy preparation, is to identify the problems related to the initial problem. Then the objective of the analysis is to learn about the relations between problems in the system and to identify the key problems. The process of analysis of the system of problem of the strategy preparation process is used to construct the method of analysis.

The analysis of the complex system of problem can be addressed with the ready to use approach. These approaches are usually developed to address large range of problems. As it was explained above, the system for energy production strategy preparation has a developed structure extending into several domains. In order to perform the analysis without a ready to use approach, it is proposed to apply several analysis tools. In this way it is possible to benefit from the individualized combination of approaches: techniques, concepts etc. matching the problems we face during the analysis. However the negative effect appears here. Application of several analysis tools returns the information about the system, defines the problems, describes the relations between elements. After several applications the amount of information grows and results from different tools overlaps. The outcomes of the complex system analysis start to become complex themselves. This causes the difficulty in application of further tools and utilization of previously received data. It shows the need for a systematized approach, which will organize the application of multiple analysis and problem solving tools inside the one method.

The thesis consists of 6 chapters. Chapter one describes the known approaches to the analysis of complex systems and formulates the problem in the method. Chapter two presents the complex physical system of energy production strategy preparation process, analyzed during the construction of the method. Chapter three introduces the categorization of the analysis tools applied in the thesis. Chapter four contains the application of several analysis tools to the example complex system of problem. Chapter five presents the synthesis and conclusion is presented in the chapter six.

## Reading guide

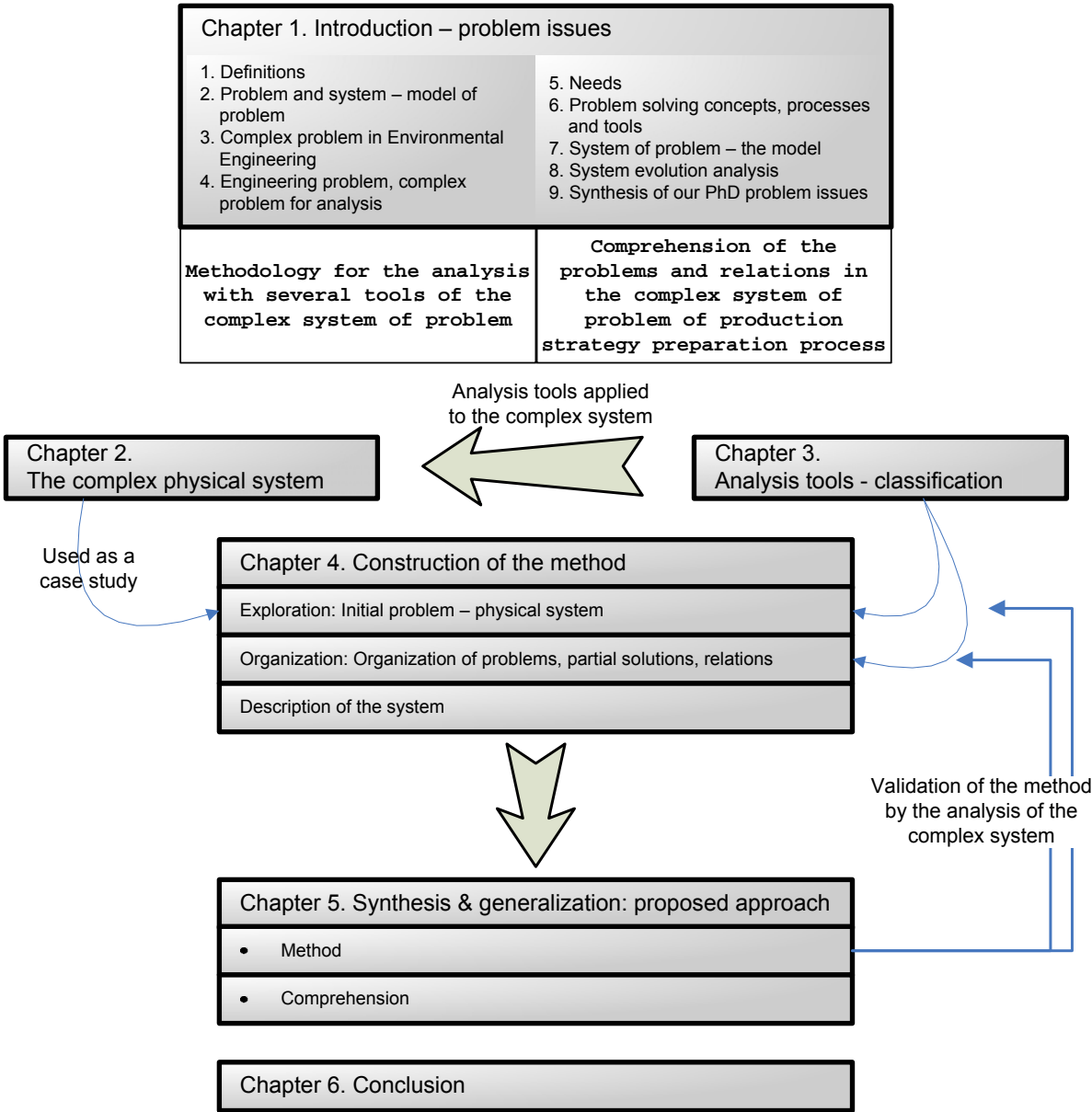

Figure 3. The reading guide for the thesis

The thesis is composed out of 6 chapters, each chapter begins with the brief introduction. Major sections of the chapter and the complete chapter are summarized by the synthesis put in

the last point of the section or chapter. The plan of the thesis presented on the Figure 3 is briefly described below referring to the particular chapters.

#### Chapter 1. Scope and aim

Introduction makes an insight into the features of known problem solving and complex system analysis approaches e.g. Agents Theory, System Dynamics, Evolutionary Design. The main features of the complex system of problem are presented on the example of the systems from environmental engineering. Comparison of approaches and features of complex systems is used to formulate the aim and scope of the research.

#### Chapter 2. The system of the energy production strategy preparation process

The system of the energy production strategy preparation is introduced in this chapter. The system is described by the relation with the environment where it is working, decision making process, which it is part of and energy production technology process controlled by the production strategy. The operation and utilization of the model by the means of the BoFiT TEP software is also explained here.

#### Chapter 3. Analysis tools – introduction

Analysis tools are classified as theories, methods, techniques, procedures, rules, models and concepts. Analysis tools applied in the thesis are arranged in groups in the table with the description of the objective and area of application.

#### Chapter 4. Analysis of the problem

The analysis of the production strategy preparation process, starts with the application of analysis tools used for the collection of the information of the system. This group of tools is called later on, the ‘exploration’. The applied analysis tools are supported by the tools for the organization of results from the analysis and information management.

#### Chapter 5. Synthesis and generalization

This chapter presents the solution in the construction of the method for complex system analysis introducing the control over three areas of the analysis: exploration, guidance, management. Each of the area is composed out of the existing techniques, rules and concepts arranged. The proposed solution in the methodology requires the application of analysis tools in three particular areas - exploration, guidance, management - but the names or number of the particular tools, which have to be used, is not restricted.

#### Chapter 6. Conclusion and perspectives

The proposed method allows the application of several analysis tools, solving the problem of control by application of tools for information management. This allows the gradual construction of the method during the analysis of a strategy preparation system.

The physical system of preparation process of the energy production strategy, the model of problem included the problems from different domains of engineering. The introduced method improved the ability of the expert to analyze problems in this complex system of problem.

### The thematic reading – following the particular subject

The table presented below proposes the reading of the thesis following the particular threads developed in the thesis. There are three main threads developed in the thesis. Throughout the thesis these three threads are interlinked and they rely on each other.

Table 1. Thematic reading

	Tool for the comprehension of the complex system	Method of analysis with several analysis tools of the complex system of problem	Analysis of the physical system
Context	Chapter 1 Points:2, 3, 4, 5	Chapter 1 Point: 1, 6, 7, 8	Chapter 1 Points: 1, 2, 7
Problem issues	Chapter 2, Chapter 1 Point: 9	Chapter 1 Point: 1, 2, 4, 9	Chapter 4 Point: 1
State of the art	Chapter 1 Points: 6, 8, 4	Chapter 1 Point: 6 Chapter 3	Chapter 2
Contribution	Chapter 4 Point 2 Chapter 5	Chapter 4 Points: 1, 2 Chapter 5	Chapter 4 Points: 1, 2, 3
Validation		Chapter 4 Points: 1, 2, 3	Chapter 4 Point: 1, 2, 3

### Main abbreviations used in the text:

DH – District Heating

DM – Decision Maker

GENCO – Energy Generation Company

MIP – Mixed Integer Problem

PSt – Production Strategy

---

## Chapter 1. Scope and aim

---

This chapter is dedicated to the presentation of the issues addressed in the thesis. In the following points the issues of the analysis of the complex system are presented from the different points of view:

- Point 1 Vocabulary: system, problem, solution, problem solving, complexity of system and complexity of problem solving.
- Point 2 presents the understanding of the relations between the physical system and the system of problem.
- Point 3 presents the view on the complex system in the domain of Environmental Engineering.
- Point 4 introduces the system of the process of preparation of the energy production strategy.
- Point 5 lists the needs referring to the analysis of the complex system of problem.
- In point 6 the set of recognized analysis tools is presented in order to give an idea how the analysis of the complex system of problem is addressed in various approaches.
- Point 7 proposes the schematic view on the model of the system of problem.
- Point 8 presents a brief insight into the evolution of the technical system.
- Synthesis of the problems addressed in the PhD is presented in point 9.

### 1. Definitions

The introduction to the thesis and the following chapters apply several specific terms in the particular context. It is necessary to provide the definitions of these terms in order to clarify the meaning intended by the author.

System – it is a set of interrelated entities. Each entity has a defined function and each entity is described by parameters. Entities are linked together by the relations. As the relation appears between two or more entities, this assembly has a new function. This new assembly is a system – it performs the function, which was not possible to realize using entities of this system when they were separated.

Entity – elements which can be individually defined or considered.

Interrelation – way of grouping in accordance with common concept

Problem – Problem appears in the system if there is a contradiction between the current state of the system described by the parameters and the desired state of the system. In the problem situation it is unknown how to transform the system from the current condition to the desired

condition described by the parameters. Using the other formulation, the system with problem is inconsistent, there is a contradiction or several contradictions present. The desired state of the system is then, the consistent system, when the consistency is achieved between the desired and current characteristic of a system.

Solution – it is a state of the system where there is no contradiction between current state of the system and the desired state of the system. There is a consistency between desired and current characteristic of a system, contrary to the system with problem, which is inconsistent. The solution is a result of the resolution of the contradiction in the system. The solution of the formulated contradiction is valid under the condition that it does not cause to appear a new problem limiting the solution.

Problem solving – it is a process transforming the system with the problem into the system with the solution. The problem solving process starts with the identification of the problem by describing it in the form of contradiction. At the next stage the problem is modeled and the set of solutions to the problem is proposed. The last stage is the application of the solution. The process is performed using the resources from inside or outside the system. The process of problem solving applies tools to analyze and model the problem e.g.: concepts, models, problem solving approaches including: techniques, methods and theories. The problem solving may be performed by the optimization of a problem or by the way which require changes in the model.

System of problem – as it was stated in the definition of ‘problem solving’, the process of problem solving starts with the formulation of a problem in the form of a contradiction. The formulation of contradiction or set of contradictions is based on the system where the problem appears in the particular situation conditions. The formulated set of contradictions is linked with the original system but it forms also the new entity described as the system of problem. The original system where the problems appear is a physical system.

Physical system – it is a system where the initial problem appears. Different problem solving approaches, applied during the problem solving process, support the formulation and reformulation of the problems. These problems are linked directly and indirectly to the physical system but they belong to the system of problem.

Complexity – appears when, in the limited amount of time, it is impossible, to explicitly describe the state of the system after the modification of one of its parameters (or set of parameters).

For example: let’s consider the system composed out of two elements: element A, element B and the finite number of connections between these two elements. The elements contain a function and they are described by the finite number of parameters, equal for each element. The connections have the associated functions transforming instantly the value of the parameter describing one element into the value describing the other element. The state of the system is described by the value of the parameters. At the time 0 the system is stable, it means no values are exchanged through the connections.

- The system is not complex if in the limited amount of time it is possible to describe the state of the system after the change of one parameter e.g. there are three relations between A and B, the description of the system’s state requires the calculation of the exchanged parameters.
- The system is complex when it is not possible to describe the state of the system or even anticipate this state using the available resources e.g. human reasoning capacity, limited time, limited computing power.

The effect of complexity is increased by the: number of connections, unknown connections, connections described by unknown functions, synergy effect, leverage points, number of elements.

Complexity of the physical system – see point 4

Complexity of the system of the problem – see point 2

Complexity of problem solving – see point 7

## 2. Problem and system – model of problem

Concerning the creation of the new method for problem analysis, this paragraph is dedicated to the description and visualization of the relations between problem, physical system, system of problem and the model of problem.

The problem is a property of a system. The system where the problem appears is the physical system and then also the system of problem. A goal which is associated with a problem is also a part of the considered system.

The fundamental process, which takes place during the problem solving, is the transformation of the problem into the solution. Both elements, problem and the solution, are described by the parameters. The parameters describing the problem are formed in the contradiction, which is then solved in the solution. The description of the problem is also accompanied by the description of the goal indicating the desired state of the system after the solution.

The problem solving process can take place in physical system and in the system of problem. If the problem solving begins in the physical system, the problem with the additional description by parameters and the goal, forms the system of problem, but it is still connected with the physical system. In this description it is possible to notice the partial separation of the problem from the physical system, where it has its origin. The problem solving process can also operate directly on the elements of the system of problem created in the problem modeling during the problem solving process.

During the problem solving process, the description of the problem evolves thanks to the application of the analysis tools. The description of the problem is changed from fuzzy to detailed, in other words, the system of the problem is changed from inconsistent into consistent (the inconsistency between desired and actual state of the system). The culmination of the problem solving process is the identification of the problem's reason. In the following stage the solution or set of solutions is proposed. As a result the solution is described by the parameters indicating that the problem has been solved. The process is schematically presented on the (Figure 4).

In the description of the problem solving process above, the system of problem has been distinguished from the physical system. In result there are two closely related systems. The physical system is the origin for the initial problem. The system of problem is a system which is directly addressed by the problem solving approaches because it represents the relations between problems identified by the analysis of the initial problem and the physical system. Both of these systems are described by the set of parameters, see (Figure 5).

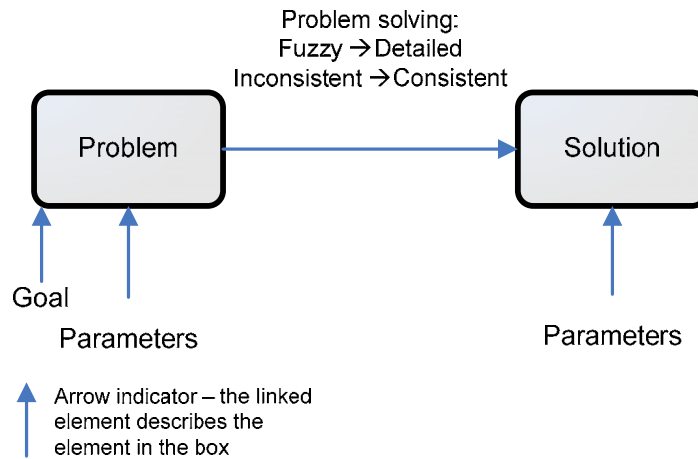

Figure 4. Transformation from the problem to the solution – problem solving process

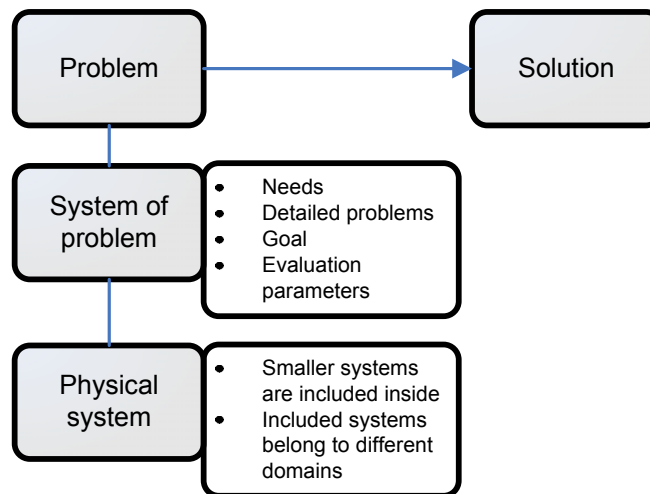

Figure 5. Relation between physical system and the system of problem

Depending on the problem, which is a part of the system of problems, the relation between problem and the physical system may vary. In order to perform the problem solving process, it is necessary to have the entity, the model formed out of the element of the system of problem and the physical system. This entity is a paradigm, it is model of a problem applied for the problem modeling and solving purpose. The problem which is modeled and solved here is the problem from the system of problems, it is distinguished from the main problem. (Figure 6)

Complexity of the system of problem – appears in the relations between different problems defined in order to describe the initial problem in physical system. In order to describe these problems in more details, more problems are identified and linked into the system of problem. When the objective is to describe and identify the key problem, the complexity is reflected by the difficulty to manage the description of the problems and their relations.



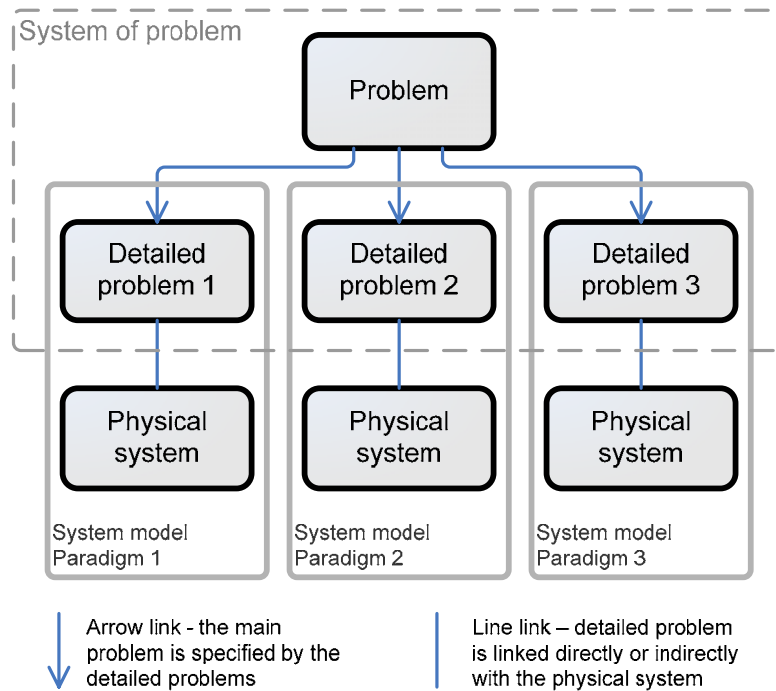

Figure 6. System of problem – paradigms, models of the system

### 3. Complex problems in environmental science and practice – Classification

Environmental engineering, from one point of view, is a group of the engineering domains treating the subject of preservation of the human living space, human living environment. This group of engineering domains includes the supply and removal of such essentialities as air and water. These tasks are realized thanks to the engineering knowledge about the treatment and maintenance of the air and water quality i.e. filtration, water and sewage treatment. Next group of systems for maintenance of the human environment is preservation of right temperature. Maintenance of the thermal comfort is a task for many solutions in the heating and cooling systems. To complete the list of services covered by the environmental engineering there is also the waste treatment issue, solutions in furnace construction, fuel delivery systems, etc. Environmental engineering links the research and development (R&D) activity in all of these domains with the application of them in the construction of larger systems.

In the environmental engineering, in many domains, innovation drives a progress for the whole branch. The progress here has two origins: the innovation in the domains, which compose the environmental engineering, and the innovation in the system's structure. The system is created to serve purpose of the environmental engineering. The consequence of this duality is that designer has to keep a sharp eye on the development and innovation, on one hand of the basic components of the systems and on other hand of the new structure of systems where they are applied. For the best effect the new appliance has to be used in the system which uses its new property. If this is achieved then the system has a certain edge over the systems designed in the past.

With the arrival of a new and better element of the system, the main attention is focused on its better performance. In the engineering practice we can tell that less attention is paid to the entire structure of the system. The main structure of the system is usually taken from the existing solutions. The frame of the system is then filled with the appliances. The redesign of the main structure of the system requires much R&D work and is usually performed for the particular solutions, thus it has no prolonged life in the professional applications. In the everyday practice it is easier to use an existing solution and adjust it to the particular conditions.

In order to create a successful design, the engineer of the environmental engineering has to be able to master, on the one hand, knowledge about the main system solutions like for instance water supply, water evacuation, and heating system, and on the other hand, knowledge about functionalities of many components of these system like pumps, piping systems and fuels. Besides designing systems, another crucial role of the engineer is to recognize its dysfunctions. In order to recognize the dysfunctions of a system it is necessary to learn about the system effect. The system effect appears when cooperation of e.g. two elements creates a new desired or harmful function, which is impossible to get from the two separate elements alone. The system effect appears in every system and its importance rises with the size of the system and the number of appliance integrated into the system. These factors increase the complexity of the system.

Complexity can be seen both as an advantage and a disadvantage of the system. On the one hand the analysis of the complexity shows many opportunities to control or improve the system. On the other hand the complexity may also be confusing when it appears to be difficult to verify all reactions to the modification introduced into the system. Engineer, who needs to maintain, change or introduce an innovation into the complex system, faces a situation that requires several kind of information and know-how:

1. access to deep knowledge of the system, which can be learnt
2. navigate among the pluridisciplinary problem of the system of problem and master their interactions,

In the material presented in this document I would like to focus the attention on the process of analysis of the problem originated in the physical system from the domain of environmental engineering. The process of the system analysis needs to be systematized. The environmental engineer, in the professional practice, has to deal with situations, which can be described, as a design process and need of comprehension of the complex system. That requires the knowledge from diverse domains, which cannot be replaced with the knowledge of separate experts in particular fields. The work presented in this document has an objective to address the following issues:

- Manage the utilization of the analysis tools for the efficient problem analysis.
- Manage the information and partial results obtained through the analysis of the particular problem for the further development of the problem.

### 3.1. General properties of systems in the Environmental Engineering (EE):

- Large size i.e. system is spread in the territory for example water supply network, air heating or ventilation system covers entire building system.
- Long life cycle e.g. working time of CHP plant is 50 years.
- Amount of the investment,
- Size of the impact on the human environment in the macro scale e.g. water supply, water evacuation and in the micro scale e.g. thermal comfort, air quality
- Long border between the system and environment i.e. natural environment, human living space
- Systems in environmental engineering use multiply means, subsystems, including also multidisciplinary solutions in order to ensure the service e.g. indoor space heating includes following functions e.g.: fuel supply, fuel storage, heat generation, heat accumulation, heat transport, heat dissipation, heat propagation, air circulation, balance of the heat transport system, control of the parameters of the thermal comfort.

### 3.2. Classification of problems in Environmental Engineering (EE)

Where does the complexity of the problem in Environmental engineering come from? We propose below a classification of these problems in relation to five criteria.

Number of disciplines, which have to be considered in the system of problem, when the problem appears between main elements of the physical system:

- single group of functions e.g. furnace is a system with the functions for fuel incineration
- dual group of functions e.g. boiler is a system with the functions for fuel incineration and heat transfer to the water
- multi group of functions e.g. heating system includes boiler, heat transport system, heat propagation system in the destined space.

Complexity – criteria

- Number of systems included inside the main system
- Number of dynamic systems or dynamic element
- Relations with the systems which the considered system belongs to

Stage in the system's life cycle:

- design – the objective is to serve current needs and ensure sustainable development into the future,
- operation – the objective is dynamic cooperation with the outside environment of the system i.e. natural environment e.g. precipitation for the water evacuation system; human behavior for water or heat usage from the centralized source)
- deconstruction (dismantling), reconstruction e.g. elements, substances for reutilization, waste storage, disposal.

The sort of service

- water circulation – including: water well pumping, water treatment, fresh water supply, hot water supply, water evacuation, rain water evacuation, sewage transport, sewage treatment
- thermal comfort – including: cool or heat generation, transport of the energy carrier, exchange of the energy carrier e.g. water to air, energy propagation at the destination
- air quality – including: maintenance of the temperature, humidity, filtering, transport, delivery to the destination space

Medium (means)

- clean water, used water, hot water, air, heat radiation, mixtures (air or water with solid particles e.g. in filtering systems)

#### 4. Engineering problem, complex system for analysis

The method of analysis of complex system will be constructed working on the case of the energy generation system for the urban environment. The physical system used for the construction of the analysis method of complex system of problem, should fulfill several requirements. (Table 2)

Table 2. General characteristics of the complex engineering system analyzed in the thesis

<b>Requirements for the system used for the construction of the analysis method</b>	<b>Qualities of the urban energy generation system</b>
It should be an engineering process linked with the technology	Energy generation includes the technology process from fuel incineration, steam generation to electricity generation, heat generation and supply
The system should be qualified as an EE system	EE system includes: heat generation in the cogeneration system with the electricity (CHP plants), Heating Stations, district heating, fuel supply, emissions to the natural environment repository
The system of problem should include problems from several engineering disciplines	The multidiscipline can be observed on many levels: in technology e.g. various solutions in generation of heat and mechanical power, in larger view e.g. link with the fuel supply chain and energy distribution grids.
The system should be complex	It has many elements. The elements have the mutual relations. The system produces and it is influenced by the dynamic changes.

The system of the urban energy generation is a place where many processes realize their functions in order to fulfill the main objective, which is – to continuously satisfy the demand for energy. From the point of view of the energy generation company (GENCO), including also CHP, there is one process which controls the system and designs the target for the entire production process. This process is the preparation of the production strategy. Production strategy takes into account all stages of the production process and one of its main functions is to manage the relations between all components of the physical system. The complexity of the

physical system seen from this process is also increased by the existence of the parameters changing dynamically in time e.g. heat demand.

The selection of the preparation process of the energy production strategy as a physical system for the construction of the analysis method of the system of problem has positive and negative aspects. Positive or negative evaluation is based on the perceived facility of analysis of the physical system and the system of problem.

The utilization of the process of preparation of the energy production strategy as a physical system has the following positive and negative aspects:

Positive aspects e.g.:

- It is formalized
- It has a link with the all elements of the technology system
- It controls the link between the technology system and the environment e.g. weather conditions, energy demand, price of fuel and price of energy.
- It has limitations common for different GENCO e.g. start-up, shut-down times of utilities, hours of trading session, limited computing power

Negative aspects e.g.:

- Some subsystems in the system of problem require the expert knowledge from outside of the EE e.g.: optimization algorithms in the solver, advanced energy trading mechanisms on the energy market.
- It requires the software to manage the process. Applied software introduces the particular solution in the physical system.
- The process includes many solutions to the problems, which have been appearing in the past and these source problems are not always evident from the present point of view.

Complexity of physical system – it is caused by the number of elements and relations in the physical system e.g. technology system for energy production, system for preparation of the energy production strategy, system of energy distribution and trading. The physical system is also dynamic what results in dynamic changes in variables describing the elements, relations and their characteristics.

## 5. Needs

The major need in the analysis of the problems in EE is to deal with the multi disciplinary character of the problems. The multidisciplinary characteristic is associated with the entire system. This kind of system is composed out of subsystems, which belong, by their individual characteristic, to the domain different then the other subsystems in this system. In this situation, describing the problem from the level of the system we say that the problem is multidisciplinary. Tracking the reason of the problem requires the analysis at the different levels of system organization. The problem solving process takes place in different subsystems engaging also interrelations between subsystems them selves and the system which includes them.

It is necessary to manage the approach to the problem solving addressing the problems from several disciplines. For instance, the multidisciplinary approach can be demonstrated as

the group of experts, each from different discipline. Each expert addresses the problem from the system of problem which he or she is familiar with, this is the problem from his or her discipline. These groups act together by building the knowledge and resolution of the problem. The solution has an added quality because it benefits from knowledge in different domains. This can be compared to the solution worked out by a single expert - working alone - for a single problem associated with his domain. The problem described by alone expert has a position in the system of problems, but it is not necessarily the key problem in the system of problem defined for the same conditions by the group of experts. The group of experts develops the larger system of problem and then they have the possibility to identify the key problem whose solution will be the most robust.

The problem solving process, of a system of problem including problems from several different disciplines, requires structured systematic approach.

The method for analysis of a complex system of problem has to satisfy following needs:

1. Analyze the complex system with the multidisciplinary components.
  - Analyze the system of problem.
  - Explore the structure of the system i.e. super-system, subsystem; in the active search for the problem's reason.
  - Apply the problem solving tools addressed to the system and subsystems.
  - Identify the key problems.
2. Coordinate results from analysis of the diverse problems.
  - Guide the analysis at the initial stage.
  - Manage the exploration of the system.
  - Collect the results from the analysis.
  - Manage the problem solving process.
3. Present the results for the internal and external use.
  - Provide the view on the configuration of the system, problems located in the system and the results from the progressing analysis.
  - Understanding of the problem in order to drive further analysis.
  - Communication of the results.

## 6. Problem solving concepts, processes and tools

The problem analysis has a significant place in the design process. It is usually assumed to have place at the beginning of the engineering process, at the study stage. In fact, it is the most visible at the beginning, because there is a need to decide about the solution of the entire project. However the problem analysis takes place during the entire process of the project realization.

The particular profile of the professions included in the environmental engineering (EE), makes it possible to address in two ways, the question of the systematic approach which is going to be applied in this domain. First, systematic approach can be considered as a problem analysis addressing the entire system, the conglomerate of the applied engineering professions e.g. heat generation and supply system, air conditioning of the office spaces. Second way of addressing the problem analysis, is the work on the one particular engineering subsystem

inside the main environmental engineering system. In this case the characteristic of the subsystem, is narrowed and more individual e.g. strategy of heat generation, air circulation in the office space. Thanks to this separation, in the second way, it is possible to select the analysis tool which will well address the problem. In order to sum up, from the system point of view, the problem in EE has a typical structure of system including sub-systems and sub-problems; but it should be underlined that the sub-systems belong to several engineering domains e.g. the air-conditioning system includes: solutions in heat and mass transfer in the central unit, fluid mechanics of air transport, fluid mechanics of the air distribution in the destination space.

The analysis of the complex system is used as part of a problem solving approach. Starting with the analysis of the large complex system, the most convenient would be to use one, complete, ready to apply method of analysis. Unfortunately such a method should be oriented on the kind of the system which we are going to analyze and, at the same time, it should not be specific but general in order to be able to address larger set of systems with different characteristics.

The following paragraphs present several examples of the problem solving approaches. The short description of each problem solving tool provides information about the structure of the tool and the particular approach to the system analysis and to the problem solving. In order to evaluate the advantages of the particular approach concerning the individual needs, first of all, it is necessary to know the objective for which the particular problem solving approach was designed for. Second important issue is to know the problem which is solved or was addressed by this problem solving tool at the origin. The problem addressed by the tool should answer to the needs of the particular problem addressed in the problem solving process.

We shall now present several existing approaches and tools for problem solving in order to position and precise the problem addressed in the thesis. The conclusion from the descriptions of the particular approaches, should give a glance on the field of the problem solving approaches. The research presented in the thesis is starting from the state of the art, which can be described by the example set of problem solving approaches presented below. The picture of this state of the art is intended to give a view of the field of knowledge where the process of the construction of the analysis method will take place, with the objective to fulfill the previously formulated needs.

## 6.1. Agents theory

Multiagent Systems (MAS) is a part of the Distributed Artificial Intelligence (DAI). An agent is an entity defined by a piece of code. An agent defined by the code has its function and, according to this function, it performs an action driven by a goal. An agent has also a domain of knowledge and it is situated in the defined environment.

The developed concept of the MAS includes the definitions of agents and MAS, properties, architectures, communication, cooperation and coordination capabilities. For the application purpose there are also definitions of agent languages, platforms for programming and experimenting with agents. During the operation of the agent, single agent or the group of agents, addresses the problem and according to the data describing the problem and the algorithm defining the function of an agent, it performs the action determined in the algorithm (algorithm which defines the behavior of an agent).

MAS is especially useful in:

- A place depending on the single entity (processor or agent) i.e. there is a risk that the fail of a single agent causes the crash of the system.
- A domain which is broken in components – this creates the separate tasks which can be taken care of by separate agents.
- Where there is a need to deal with the limitations created by the time-linked or space-linked reasoning requirements e.g. agents can be applied in different places and time in parallel.

Utilization of the multiagent systems is recommended when there is a need (Stone and Veloso 2000):

- Some domains require it i.e. increase in the reliability
- Parallelism
- Robustness
- Scalability
- Simpler programming i.e. it is possible to use agents as modules
- To study intelligence i.e. hypothesis that intelligence arises from interactions
- Geographic distribution
- Cost effectiveness

Tools: agent, multiagents system (MAS), environment, knowledge base.

Means: independently acting agent, cooperating agent, communicating agent.

Addressed problem are solution of the fragmented problems, problems that can be split into many components and solution of problems in parallel in time and space.

Addressed complexity: complexity in large systems with the stress on the parallel activities in the system both in time and in space

Application: the solution of the trading agents can be used e.g. to treat the problem of trading in the electricity markets. (Scheidt and Sebastian 2001)

Limitations - general:

- An agent performs his function automatically but it has to be written at some moment of time and it is the initial code which describes its behavior.
- Physical system and system of problem have to be described in the form of the mathematical functions because agents are in the form of programming code.

Limitations – in reference to problems in EE:

- MAS is the best suited to treat problems in the large dynamic systems in EE e.g. water distribution networks.
- It is possible to make a direct application only to the physical systems described in a form of mathematical model e.g. constructed in CAD tools and adapted for utilization of agents.

## 6.2. System dynamics

System dynamics is a methodology. System dynamics is designed to address the problems occurring in the complex systems, it is not addressing the system itself, it is addressing the problem in the system. (Richardson and Pugh 1981) The system dynamics approach to



problem analysis and solving may be performed using two fundamental techniques. First technique is the construction and analysis of the causal loop diagram (CLD). Second is the construction of the stock and flow diagram, which makes it possible to model the system's operation. The CLD diagram is constructed from variables and linked with polarized arrows (positive or negative), which show the direction of the action and indicate its positive or negative value. CLD diagram can be used to collect, present and analyze data. The structure of the CLD can shape into the one of the 11 defined archetypes of problems. (Senge 1990) Construction of the archetype or the self build and developed structure helps in understanding of the problem and relations in the described system. Polarization of the linking arrows gives also an attribute of dynamic view on the system or part of the system. The second stage is to construct the stock and flow diagram. This could be a second stage after the CLD or it can be started directly with the stock and flow diagram. Stock and flow diagram introduces the mathematical formulas to precise the relations between variables. Thanks to that it is possible to receive the quantitative characteristics of the model of the system or the fragment of the system. It is possible to observe the influence of the particular elements of the system.

Tools (model, concept): model of the CLD, model of the stock and flow diagram, feedback loop, archetypes

Means (technique): CLD construction, stock and flow diagrams construction, system modeling

Addressed problem: analysis of the problem localized in the complex system

Addressed complexity: complexity of relations between variables defined in both physical system and in the system of problem

Limitations – general:

- The CLD model is the most useful at the initial stage of the problem analysis and generally as a support for representation of the relations between variables in order to describe the part of the system.
- The variables and functions in the model have to be carefully described.
- The best effects are obtained from system dynamic simulation with stock and flow models.

Limitations – in reference to problems in EE:

- As EE is connected with natural environment there may occur unperceived leverage points.
- In EE systems with important, direct interaction with the natural environment it is difficult to perceive, identify and put into the model all relations and variables relevant for the considered problem.

### 6.3. Evolutionary design

The evolutionary design system mirrors the process of natural evolution. The evolution starts from the set of designs which can be called a population of alternative designs. Then the natural selection is simulated, where more successful designs have a higher chance of selection for reproduction. The process of reproduction will then generate new designs that keep some features from their parent designs and have some entirely new features. The selection of the successful design is made after the simulation of the evolution of the proposed

population of design set in the defined environment. The performance of the design is evaluated. The evaluation phase is followed again by the creation of the new code script population of design by copying and transforming the most successful code scripts from the preceding population. The new code population becomes the starting point for the new cycle. (Janssen, Frazer et al. 2002)

Model, concept: design proposals, environment, populations, evolution

Technique: selection of the successful design; keeping the successful features, elimination of unsuccessful and introduction of new features

Addressed problem: simulation of the evolution of the system in order to analyze it and to perform the design process, to move the design to the next generation. In order to use this technique in the design method, the evolution has to be simulated, therefore the model of the system change has to be preprogrammed.

Addressed complexity: complexity in changes in elements and relations between elements, in the physical system and system of problem, as a result of the evolution of the technical system

Limitations – general:

- It requires the information about previous versions of the physical system.
- Difficulty in backtracking of the evolution.

Limitations – in reference to problems in EE:

- The evolution with the preprogrammed model of system evolution requires the formulation of a mathematical model.
- Systems in EE are constructed and work in particular conditions, locations which may be not always comparable for the purpose to describe the evolution of a technical system or to apply the solution e.g. water distribution system in cities with different historical influences.

## 6.4. Theory of constraints

Theory of constraints (TOC) is a methodology that works based on the thinking process which has an objective to create the knowledge base about the system. The TOC acts by analysis of the cause-effect relations in the system. The analysis of the system is focused on the search for the cause of the problem inside the structure of the system. The cause is identified as a weak point, a constraint to the function performed by the system. The constraint is located looking on the system from the system level rather than focusing on the optimization of the particular sub-system, the effect for the entire system matters.

The five steps analysis presented below gives an insight into the TOC mechanism (Dettmer):

1. Identify the system's constraints. Determine what limits the system's performance.
2. Decide how to exploit the system's constraint. Eliminate inefficiency from the constraint.
3. Subordinate everything else to the above decision (step #2). Make effective management of the existing constraint the top priority.
4. Elevate the system's constraint. Break the constraint by increasing its capacity above the level of demand.

5. If, in the previous steps, a constraint has been broken, go back to step 1, but do not allow inertia to cause a new constraint. Go back and find the next weakest link which limits system performance.

Technique: search for the weakest point in the system performance

Addressed problem: management and improvement of e.g. group work, production processes

Addressed complexity: complexity of elements interacting in the system, number of limitations included in the functions describing the relations in the physical system

Limitations – general:

- Constraints in the system should be known and described.
- The way how to eliminate the constraint is not given in TOC.

Limitations – in reference to problems in EE:

- Large systems in EE are individualized for the particular application, then many constraints are changing for different conditions.
- TOC requires from a user a good knowledge of elements and relation of the physical system and also the system of problem.

## 6.5. KJ method

KJ method is called also an affinity diagram. (Sage and Rouse 1999) An affinity diagram helps to synthesize large amounts of data by finding relationships between ideas. It can be used as a form of an organized brainstorming, organization of the data from the brainstorming session or simply to work on the large set of data.

Affinity diagrams can be used to:

- Draw out common themes from a large amount of information
- Extraction of the meaning from the raw data
- Discover previously unseen connections between various ideas or information
- Brainstorm root causes and solutions to a problem

The result of utilization of the KJ method is:

- Disclosure of the common threads, relationships that link the groups of information, facts.
- The disclosed relationship is named.
- Recognition of the common threads leads to the solution or best idea.

Model, concept: similarity of the ideas, relationship between ideas, facts

Technique: steps in the group formulation procedure: identification of similarity, relationship, definition of the group with common feature, formulation of the group's name.

Tool: organization into common themes, utilization of separated pieces of paper to write the name of the idea, data, one per each piece of paper in order to move them easily between proposed themes

Addressed problem: high quantity of data, need for an efficient use of the high quantity of data which is available in the certain situation, dealing with lots of information from various sources, encouragement to write the concept instead of saying it (refers to the team work)

Addressed complexity: high number of information, high number of ideas, high number of unknown relations

Limitations – general:

- It was created to work on the ideas generated during the brainstorming session.
- It is recommended to use this method in a group of people in order to diversify the point of view on the information, themes, connections.

Limitations – in reference to problems in EE:

- It has an application narrowed to the utilization of data from brainstorming or in situation when EE physical system is a part of a larger physical system.
- Interaction of the EE system with the natural environment introduces high number of themes into the KJ method.

## 6.6. C-K theory

C-K theory is a theory of description of activities of design methods. It is not prescriptive theory. The C-K theory is a unified design theory. Its central proposition is the distinction between concepts and knowledge. The process of design can be defined as a process generating the co-expansion of the two spaces, the space of concepts (C) and space of knowledge (K). There exist 4 types of operators described as interaction between the two sets:  $C \rightarrow K$ ,  $K \rightarrow C$ ,  $C \rightarrow C$ ,  $K \rightarrow K$ . The K space includes propositions with the logical status expressing the confidence in the proposition i.e. true, false, undecidable. The C space includes concepts which are propositions built from the elements coming from K, but they have no logical status in K. It is impossible to prove that a concept is a proposition in K. The definition of design formulated in C-K theory is a process by which concept generates other concepts or becomes a proposition in K.

The interactions between C and K can be presented in the shape of the ‘design square’. This form shows the description of the design process from the point of view of the C-K theory as a process taking place between and within spaces of knowledge and concepts. (Hatchuel and Weil 2002; Hatchuel and Weil 2003; Hatchuel, Le Masson et al. 2004)

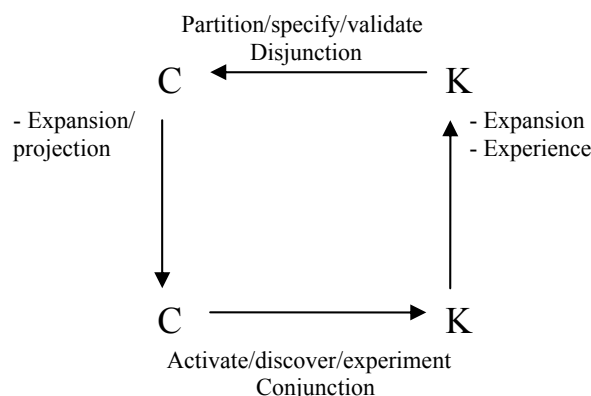

Figure 7. The design square (Hatchuel, Le Masson et al. 2004)

Model, concept: space C (concept), space K (knowledge), design definition

Technique: systematic design process operating as a co-expansion of two spaces, space of knowledge and space of concepts

Addressed problem: structures the design process, definition of the design process

Tools: operators (external  $C \rightarrow K$ ,  $K \rightarrow C$  and internal  $C \rightarrow C$ ,  $K \rightarrow K$ ), disjunction process  $K \rightarrow C$  (utilization of the knowledge to create the concept), conjunction process  $C \rightarrow K$  (adding the logical status to a concept, by partitions and inclusions)

Addressed complexity: complexity of the knowledge circulation during the design process and problem solving process

Limitations – general:

- For some cases the knowledge in the K space is large and this may cause a problem to handle the K space.
- Need for the initial concept (See case examples in (Hatchuel, Le Masson et al. 2004))

Limitations – in reference to problems in EE:

- The elements of the knowledge space belong to different domains – this forms subgroups in the K space which should be recognized.
- The utilization of the ‘design square’ has to be mastered for the analysis of a system in EE with high number of elements and connections.

## 6.7. IDEFØ

IDEFØ (Integration Definition for Function Modeling) is a concept applied according to the formulated rules and techniques. It is used to develop structured graphical representation of a system or enterprise. With the use of the IDEFØ it is possible to construct models which contain:

- functions of the system i.e. activities, actions, processes, operations,
- functional relationships,
- data i.e. information, objects.

The modeling technique can be characterized as:

- generic – in order to analyze systems of different purpose, scope and complexity,
- rigorous and precise – in order to produce correct and usable models,
- concise – in order to facilitate understanding, communication, consensus, validation,
- conceptual – in order to represent functional requirements rather than physical or organizational implementations,
- flexible – in order to support several phases of the lifecycle of a project.

IDEFØ, as it was pointed out above, is not designed to represent the physical relations and processes. The construction of the model is open to the functional relations between elements of the model. Construction of the model is regulated by the syntax and semantics.

IDEFØ is a modeling technique based on the graphical and text elements organized in a systematic way to provide understanding, support analysis, provide logic for potential changes, specify requirements or support systems level design and integration activities. An IDEFØ diagram is built from hierarchical series of diagrams that gradually display increasing levels of detail describing functions and their interfaces within the context of a system. The graphic diagrams define functions and functional relationships via box and arrow syntax and semantics.

Construction of the IDEFØ diagram is a technique used to perform and manage analysis of needs, benefits analysis, requirements definition, functional analysis, systems design, maintenance, and baselines for continuous improvement. The IDEFØ model reflects how system functions interrelate and operate. Each diagram presents no more than 6 boxes each containing single function. The diagram for the entire system is developed using the decomposition to the next level inside the box. Each box with a function is presented as a rectangular shape. Each side of the box has a defined input/output meaning. The connection of the arrow with a particular side of the box defines the meaning of an arrow. Arrows entering the left side of the box are inputs. Inputs are consumed or transformed by a function, in the box, into the outputs, which are coming out from the right side of the box. Arrows entering the box on the top are controls. Controls specify the conditions needed to produce correct outputs by a function. Arrows connected to the bottom side of the box represent mechanisms. Upward pointing arrows indicate the means that support the execution of a function. Downward pointing arrows indicate a call, which is a mean to share details between models.

Systematic application of the IDEFØ provides the systems engineering approach:

- Performing system design and analysis at all levels,
- Producing reference documentation of a system for the improvement of an existing system or integration of new systems,
- Communicating among analysts, designers, users,
- Allowing coalition team consensus to be achieved by shared understanding,
- Managing large and complex projects,
- Providing a reference architecture for enterprise analysis, information engineering and resource management.

IDEFØ is a part of a group called IDEF techniques. It includes: IDEFØ (functional model), IDEF1 (information model), IDEF2 (dynamics model). (Secretary of Commerce 1993)

Concept: IDEFØ is a concept used for the development of structured diagram representing the system

Model: a box containing a function and links with defined meaning depending on which of 4 sides of the box they are linked to.

Technique: construction of a structured diagram out of the function boxes and links

Tools: Construction of a diagram supports the discussion with experts and it is a tool to obtain information about the functions and relations in the system.

Addressed problem: modeling of a system, cooperation with experts, development of an existing system, understanding of relations in the system

Addressed complexity: complexity of relations between elements of the physical system

Limitations – general:

- It is suited for work with a group of experts.
- The presentation of the functions linked in one process e.g. technology process, should be avoided.

Limitations – in reference to problems in EE:

- It supports the work on the model representation of a system but it is not a problem solving approach. However the solution may appear during the analysis of a physical system.
- The dynamic features of the functions are not included in IDEFØ, it is required to use IDEF2.

## 6.8. OTSM-TRIZ

The TRIZ is an acronym for the Theory of the Inventive Problem Solving. TRIZ is a domain of science that explores the mechanisms of technical systems evolution in order to develop applicable analytical methods and problem solving techniques. (Altshuller 1991) The problems are being described on the set of models that are based on the contradictions. The contradiction includes the positive and negative values of the two parameters in conflict with each other. The required result is to attain the positive value of both parameters P1(+) and P2(+) at the same time. (Figure 8) The formulation of the problem and solution process is conducted respecting the three postulates, which are the base of the theory. TRIZ addresses only systems where the evolution of the system requires the solution of a contradiction. This excludes the systems where evolution is performed by the optimization. First, the problem has to be formulated as a contradiction. Second, there are the laws of the evolution of the technical systems, which are used for the problem solving. Third, the problem and the solution to the problem exist for the particular situation conditions.

There exist several kinds of contradictions. In TRIZ language, there are administrative, technical and physical contradictions. OTSM-TRIZ distinguishes administrative, parameter and system contradictions. To learn more about contradictions see (Khomenko, De Guio et al. 2007).

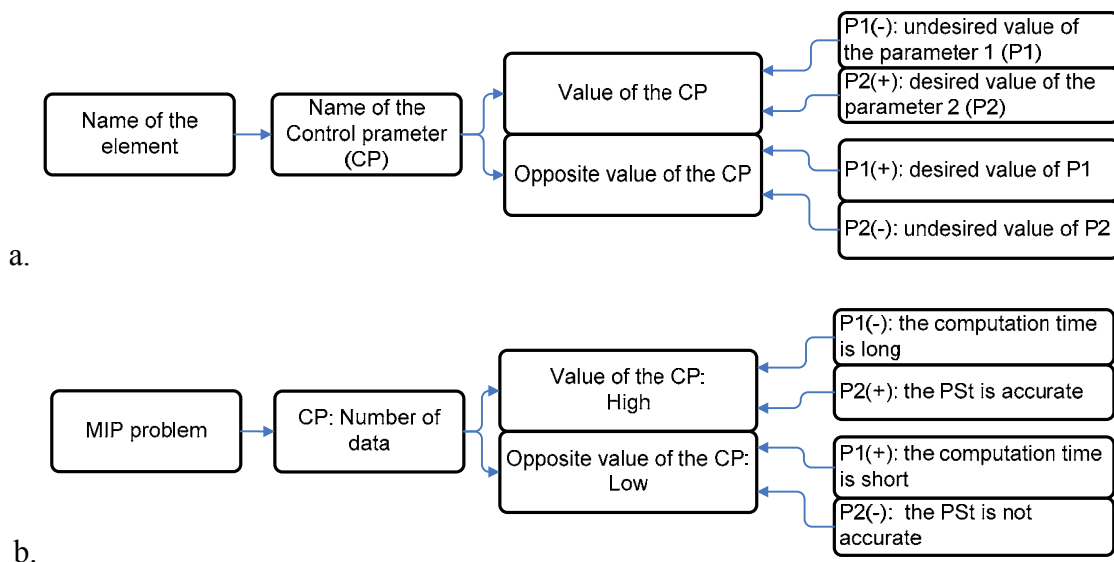

Figure 8. Contradiction: a) Elements of the model, b) Example (MIP – Mixed Integer Problem, PSt – Production strategy, PSt is a result of the optimization of the MIP)

According to the rules of the TRIZ, all problems have the place in the evolution of the technical system where they are located. The solution of the problem is a powerful solution

only if it resolves contradiction towards the increase in the ideality ratio. The solution should e.g. increase the functionality and decrease expenses. (Altszuller 1975; Kaplan 1996; Altshuller 1999; Khomenko and De Guio 2005)

The process of the problem solving using the TRIZ theory is supported by the knowledge base of the TRIZ and tools like concepts, techniques and methods. They can be used independently according to the particular needs of the user or they can be formed into the method. An example of a developed method formed from the content of the TRIZ's knowledge base, is the Algorithm of Inventive Problem Solving (Russian acronym ARIZ). In both cases, independent application and application in the form of method, the utilization of the TRIZ tools have to obey the foundation laws of the theory.

Theory of Inventive Problem Solving (TRIZ is the Russian acronym usually applied for) was developed mostly to address the engineering inventive problems. At the end of the 1970s founder of TRIZ G.Altshuller anticipated further evolution of TRIZ towards a General Theory of Powerful Thinking, which will be useful to deal with non-engineering problems and complex cross disciplinary problems as well. At the beginning of the 1980s G.Altshuller initiated research to develop this theory. OTSM is the Russian acronym usually applied to indicate the General Theory of Powerful Thinking. (Kucharavy, De Guio et al. 2007) For details see (Khomenko, De Guio et al. 2007).

The OTSM-TRIZ is composed out of four fundamental technologies (Khomenko and De Guio 2005):

- technology of the new problem – it assures the formulation of the problem from the general, not précised description of the initial situation,
- technology of the typical solutions – in case that the problem is well formulated then it can be solved thanks to the already known typical solution,
- technology of the contradiction – when it is not possible to solve the problem with the typical solution, then it is necessary to formulate the contradiction, intensify it and use the mechanism of problem solving addressing this contradiction,
- technology of the problem flow – it is proposed to manage the process of the complex problem solving by the control over the relations between identified problems.

Example of the applied analysis tools from the OTSM-TRIZ:

Model: Contradiction,

Concept: Multi Screen Scheme (also called: System operator), Network of problems, Network of contradictions

Technique: AIS (Analysis of Initial Situation)

Method : ARIZ

Addressed problem: problem solving approach for the complex, interdisciplinary problem that needs integrated application of knowledge

Addressed complexity: e.g. complexity in the number of element, number of relations, type of relations, unknown relations and elements

Limitations – general:

- Some tools are in the form of concept and require the user to construct the technique in order to use them.
- Free choice of analysis tools is a limitation for the user who has to make a decision.
- There is a need for the initial training in the application of the analysis tools.



Limitations – in reference to problems in EE:

- At the beginning in EE physical systems and system of problem, there is a high number of easy to identify problems, which then need to be reviewed to select the most relevant.
- The focus on analysis of systems from different domains with different kind of tools requires to keep a view on the relations between these system in the system of problem.

## 6.9. Synthesis

Each of the presented approaches proposes the particular way to address the complex system analysis and the problem solving approach. The presented approaches are constructed around the particular concept or set of concepts. Most of the approaches propose to the user the procedure of application of a tool. The exception is the OTSM-TRIZ proposing the set of analysis tools which can be chosen according to the need of a user. The presented information about several problem solving approaches shows that analysis tools are designed addressing the particular difficulty in the problem solving e.g. KJ addresses the high number of data, TOC the presence of constraints limiting the development. Among them there are also approaches which work on the definition of the design process like C-K theory. Whereas in the OTSM-TRIZ the user may choose the tools he/she would like to use and address the problem in the particular way. The conclusion from this review is that tools can be more or less open to the different applications. Instead of using the universal tool, it is possible to select the set of analysis tools, which will be the most useful to address the particular problem.

Complexity of problem solving – it is reflected in the variety of analysis tools which may be applied in order to build and analyze the system of problem. The analysis tools produce results which are, on one hand integrated into the system of problem and on the other hand they are used to analyze the system of problem. The iterative application of a single tool in order to analyze large system of problem or application of several analysis tools increases the number of tools' applications and their results. Therefore at the end the complexity of problem solving grows.

## 7. System of problem – the model

Description of the already existing problem solving approaches, presented in point 6 in 'Introduction', presents different solutions which have also similar general parts. It is possible to distinguish two general parts, the analysis of the problem and then the systematization of the results in order to find the solution. First of all, at the beginning of the analysis, there is a part of the approach, which performs the analysis of the problem e.g. generation of the themes in KJ method, Analysis of the Initial Situation in OTSM-TRIZ, collection of the design proposals in Evolutionary design. The second step is the look on the gathered data in a particular way proposed by the solution in the problem solving approach. In other words the results from the problem analysis are used to model the problem. Modeling of a problem

provides the guidelines for the solution to the addressed problem e.g. organization into root-cause relations in KJ method, formulation of the contradiction in OTSM-TRIZ, selection of the most successful design in Evolutionary design.

Complex systems include many elements to be analyzed, therefore in order to make an efficient analysis using one of the presented approaches, requires their repeated utilization. The repeated application of the techniques, included in the problem solving approach, generates more and more data about the system. This result is good because we would like to have more information about the system, but at the same time this result is bad because large amount of data increase complexity, it is difficult to use and to draw the conclusion from them, it is necessary to use tools to handle them. This problem can be presented in the shape of contradictions. (Figure 9) The model of the contradictions used for figure 9 comes from the OTSM model of contradictions.

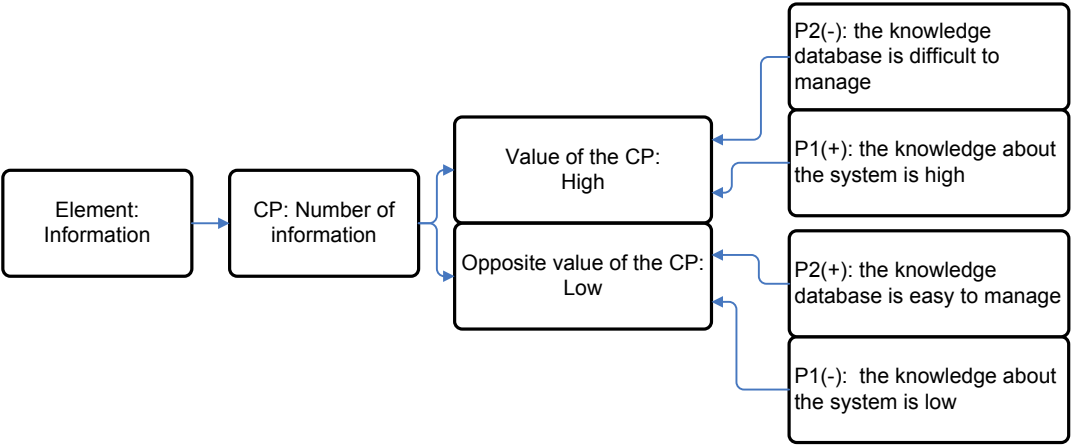

Figure 9. Contradiction – many and few information (CP- control parameter)

The contradiction presented on (Figure 9) is built to describe the problem in information. The presented contradiction including Control Parameter (CP) is the physical contradiction according to the definition in TRIZ and it is an equivalent to the contradiction of parameters in OTSM-TRIZ. The element ‘Information’ is described by the CP, ‘Number of information’. At least one common CP links the two parameters of the model P1 and P2. The element described by the value of CP has a positive and negative effect, this is a contradiction. The positive and negative effect is described by two parameters P1 and P2. Parameter it is a variable, a property whose value determines the characteristic of an element. The contradictions will be solved when two positive values of the parameters P1(+), P2(+) are assured, this is the goal i.e.: the analysis of the elements of the complex system and the management of the results for the analysis in order to form the solution. These two general needs, construction of the knowledge about the system and management of the knowledge, constitute two main elements of the problem addressed in this thesis. Further development of these two elements, into the functions realized under two corresponding threads, illustrates the system-model of the problem. (Figure 10)

The system model of problem shows the two parts of the approach to the problem solving, which have to be developed during the construction of the method for analysis of the system of problems. The system of problem is complex because of the number of problems, their mutual relations and their connection with the physical system. That is why the systematic approach to analysis is required. The control over before mentioned two parts, maintained throughout the entire process of the complex system analysis, will assure the efficient

application of analysis tools and the benefit from the results. The solutions to the two parts, developed on the (Figure 10), support one another in the process of the system analysis.

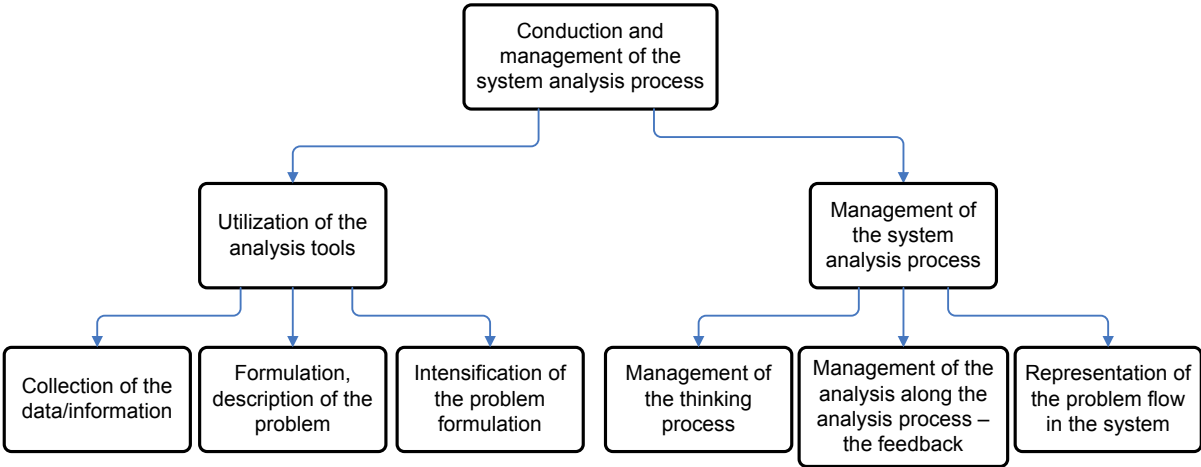

Figure 10. System-model of the problem

### 8. System evolution analysis

The systems undergo the evolution. During the evolution, some problems are resolved, some stays and some are replaced by the new problems e.g. by the introduction of the partial solutions. The transformation of complex system concerns the system as a whole but it can be also referred to the particular elements of the system. In order to describe the evolution process, it is necessary to collect the historical data about the development of the system or its element. From this information applying the evaluation parameters, which are critical to quality parameter of the system, at different moments in the time, it is possible to describe its position on the S-curve evolution line. (Kucharavy 2003)

The information about the transformation of system can be used to push the evolution forward and even to make the jumps in the development of the system. As soon as it is possible to identify the evolution of the system in the past, it is possible to better identify the current needs. This gives the different point of view on the system instead of the concentration on the current problem. However there is still need to deal with the problem currently identified in the system. Analysis of the transformation of complex system of the problem can help in this in two ways. The first way is the short-term solution. The second way is the medium-term solution, the tactical one and the third is the long-term solution which can be named as a strategy. The short-term solution is to move the system to the next stage on the evolution line. This can be performed by extrapolation on the S-curve. It is the identification of the parameters describing the next step in the evolution based on the values of parameters describing the system in the past. The selection of the parameters is supported by the description of the current problem. The next step of the evolution, the beginning of the next S-curve, is defined by the researcher working on the subject. The evolution goes to the next level when it has reached the ‘ceiling’ of a defined system and there is no more resources to continue transformation. For example, the step in the evolution of the cell phone keyboard in the short term can be the introduction of the QWERTY keyboard (configuration as in the Blackberry Pearl made by Research in Motion Ltd.) in the cell phone instead of the classic

keyboard used for the cell phones. This solution increases the speed of the text input from the cell phone keyboard because the scheme of the keys is the same as on the regular computer keyboard, which is more efficient and users are more used to apply. The long-term solution overcomes the major problem by introduction of the major change in the system. This solution is still based on the analysis of the historical data but requires the more careful analysis. For example, in the case of the cell phone keyboard, the keyboard was the source of many problems. The breakthrough solution, the solution in long-term is the keyboard where there is no keyboard, no physical keyboard at least and the function of the keyboard is still provided. Instead of physical, the virtual keyboard was introduced in the iPhone (made by Apple Inc.).

Why analysis of the transformation of complex system is difficult? The development of the system throughout the past can be described with different parameters. The parameters have to be carefully chosen or constructed in order to describe the element concerned in the problems description, but also other relevant elements which need to be identified. In order to position the current system on the S-curve evolution line, there is a need to describe the system and the environment. In order to describe what is a system, it is necessary to describe its borders. Then it is necessary to identify the evolution cycle of the system or the part of the system or both. For example, there is a cycle of the evolution of the innovations with repeating cycles for each invention called S curve (Kucharavy 2003; Kucharavy and De Guio 2007), there is also an approximately cyclical shape of the market long term value on the stock exchange.

## 9. Synthesis of our PhD problem issues

### 9.1. Scope

In order to answer the needs presented before, it is necessary to propose a new method of the complex system analysis, which will have an advantage over the existing approaches presented in point 6. As the resources to construct the new analysis method it is proposed to use several existing analysis tools. Application of the several tools during analysis of one system faces the problem of organization of particular tools and their results.

The chosen methods, techniques, concepts and models are applied in the analysis of the particular engineering problem. By the means of the analysis tools, the initial problem is described and gradually, the new problems are disclosed in the system. This fuels the further analysis, which through the systematic application of various tools, forms the method. The analysis is focused on the systematic application of the analysis tools. Particular attention has been paid to the organization of the results from the analysis of the system. The process of the method construction is composed out of two actions. First action it is the application of the analysis tools in order to analyze the engineering problem. Second action is the management of the results obtained from the analysis, conduction of the analysis and maintenance of the control over the global view on the problem and system of problems. (Figure 11) The scope of the thesis is described by the performance of these two actions mentioned above, analysis of the complex system and the analysis's management. The complex physical system used in the thesis is a system from the domain of EE, with elements of the multidisciplinary

characteristic. It is the process of the preparation of the energy production strategy for the CHP in the day-ahead energy market.

The scope of the thesis is the application of the known analysis tools in order to construct out of them the new method individualized for the particular case.

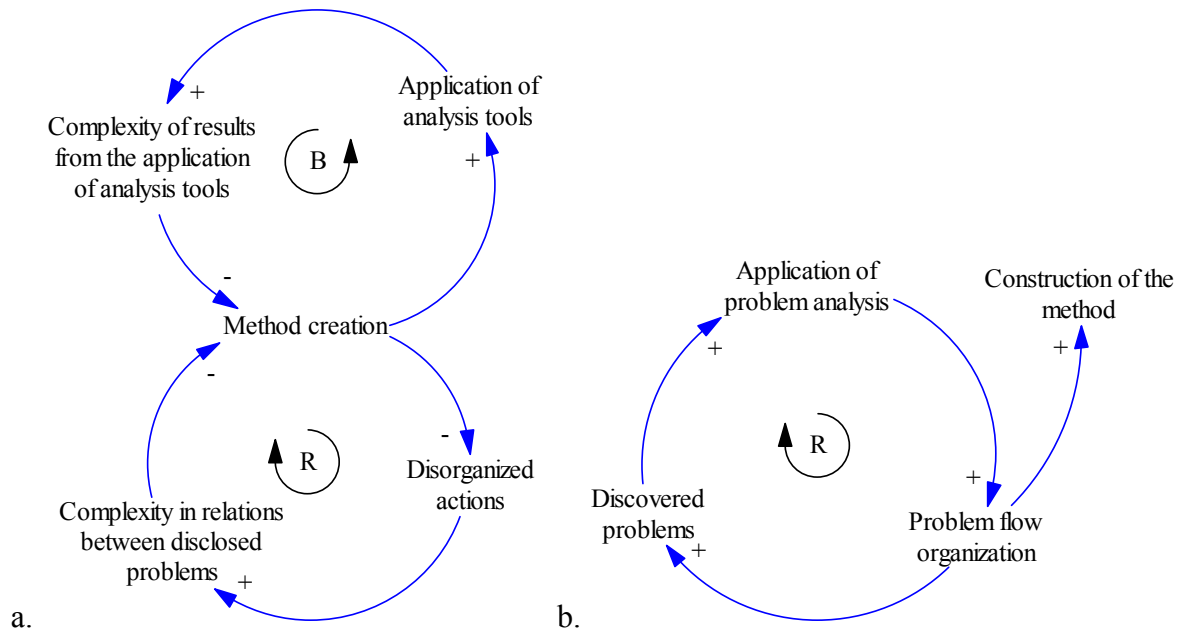

Figure 11. Causal loops presenting the method creation

The CLD presented on Figure 11 a., shows in the upper loop that the application of the increasing number of analysis tools increases the complexity in the system of problem what creates the difficulty in the creation of the method of the problem analysis. The lower loop shows that the construction of the method decreases the amount of disorganized actions in the problem analysis and clarifies the relations between problems what supports the creation of the method. CLD presented on Figure 11 b., presents simple cause – effect relations. Organization of the problem flow increases the number of described problems and supports the application of tools for analysis of the system of problem. The increase in the organization of the problem flow has a positive reaction on the construction of the method for analysis of the system of problem, what is the objective of the thesis. For the instructions on how to read the CLD, see Chapter 4 point 1.1.3 on page 92.

## 9.2. Aim

The aim of the thesis is to provide the method of problem analysis, including the problem flow management, constructed through the controlled system analysis of the particular system. The complex system including the engineering problem will be described by the means of analysis tools applied in the process of the method construction. The application of the analysis tools will be managed by the means of the problem flow management tools, progressively with the acquisition of the results from analysis. The tools of the problem analysis management will deliver the view of the result of the problem analysis. The supplementary target of the construction of the method is the comprehension of the analyzed

system by the utilization of the solution in the systematic system analysis and the tools managing the problem flow.

Analysis of the problem at the beginning, with the constant systematization of the problem's exploration, has an objective to make a quick transition from the physical system and the problem within it, into the system form of the problem. The system representation of the problem makes it possible to introduce other ways of problem solving.

The problem analysis did not apply any complete ready to use analysis method, but the analysis method is constructed from the tools of different origins. They are designated for the particular task, required to perform at the particular stage of the analysis. The method constructed in the research, which is presented in this document, is applied to the particular engineering problem. Therefore, the configuration of analysis tools and the degree of their application is tied with this particular physical system. However, the process of the method construction can be also applied to engineering problems different from the one employed in the thesis.

---

## Chapter 2. The complex system presentation – energy generation system including CHP plant

---

This chapter introduces the presentation of the system, which will be analyzed in the thesis. This presentation is organized around the main process controlling the system, which is the preparation of the energy production strategy. The procedure of the strategy preparation applies the model of the energy generation system for the urban area. For the research purpose the models of the real energy production and trading systems are supplied by the ProCom Company. These models are built, edited and computed in the software tool called BoFiT TEP (Daily Operation Optimization and Portfolio Management), made by ProCom. The models of two German cities have been used to support the analysis of the complex system giving the insight into the models and problems treated by the software. However in order to understand the functions of the models operated in the BoFiT, there is a need to take into account a bigger picture of the conditions that set the environment for the energy generation system e.g. energy market, distance to heat consumers.

### 1. Main information about power and heat generation

Electricity is generated mainly in large generation units because of technological process efficiency, services and controllability of pollution. From the power plant, thanks to the distribution network, electricity is delivered to the client. Transportation of electricity on long distance generates losses, therefore preferred localization of energy production is near the consumers i.e. industry and cities. However the pollution from coal burning plants and low controllability of the fuel transportation is the reason why the power plants are usually located near the fuel sources e.g. coal mines.

Heat energy produced along with the electricity during the same technological process is sold to the local consumer or ejected, as a loss, outside the power generation system (into the environment). Availability of the local heat consumer has an influence on the power plant design and its efficiency. If the energy generation plant is located near the large heat consumer e.g. city, urban area, a city and heat consuming industry, there is an option to produce the electricity and heat in the combined cycle. Overall efficiency of the power plant working in the combined heat and power production cycle is significantly higher (80%) than in the simple electric power plant cycle (40%).

With the introduction of the energy market liberalization, the price of the electricity is traded on the energy exchange, whereas heat energy is still sold on the basis of direct contracts with the local consumer.

Energy market, depending on exchange platform, covers different sorts of energy i.e.: fuel, electricity and related features like emission allowances. An objective of the liberalized energy market is to create conditions of competition and decrease the energy price for the consumer. Energy can be traded in two different ways – on the open market session of the

energy exchange and by the over-the-counter (OTC) contract. OTC is a direct bilateral contract. Energy exchange delivers service for trading electricity and emission rights. In general, the two sorts of trading, can be named the OTC and the Spot market.

New solutions on the energy market improve the role of the CHP plants. The opportunities linked with the component of the electricity generation inside the CHP system, made the CHP a more dynamic and important player in the urban energy system and also in the regional or national grid.(Andersen and Lund 2007) This fact drives the attention of the production planners to the position of the CHP, relations and constraints influencing the operation of the energy generation system. (Figure 12)

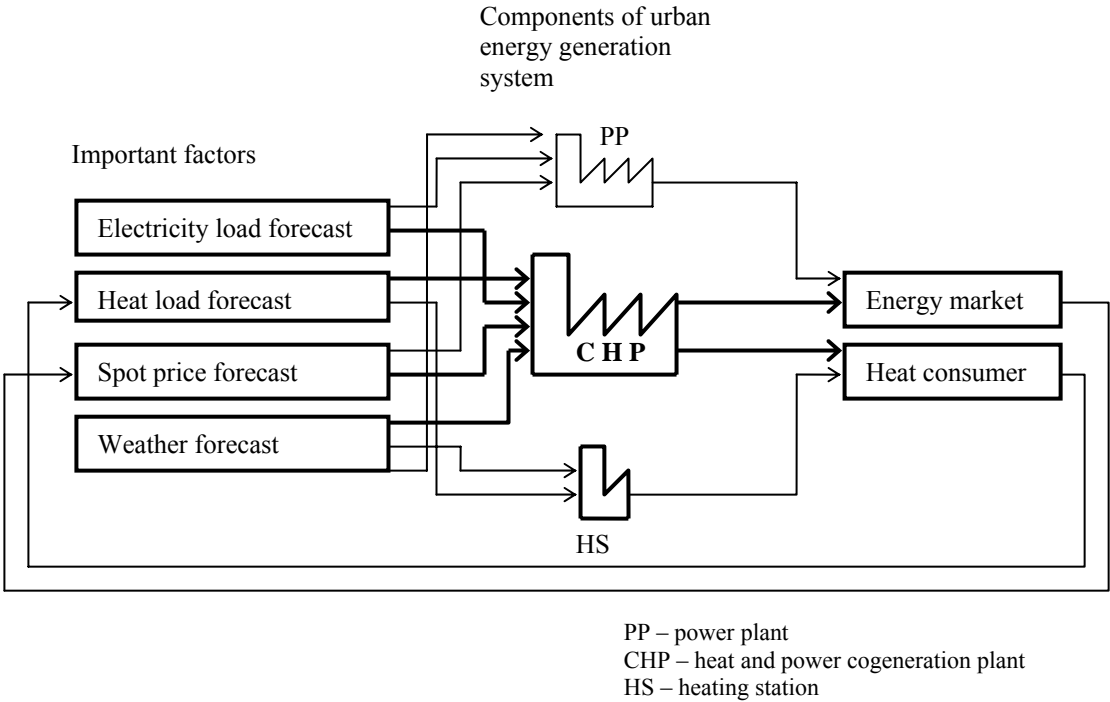

Figure 12. Position and main relations of the CHP in the urban energy generation system (day ahead market conditions)

## 2. Presentation of the engineering system

The following paragraphs present system of the preparation of the energy production strategy with the focus on different elements of the process. The process is linked tightly with the technology process of energy production. The localization of the strategy preparation in the reference to the technology process is presented in point 2.2. The focus on the CHP particular characteristic is presented in point 2.3.

### 2.1. From general view to the urban energy generation system

The CHP plant works in the environment, which can be divided into two parts, the supply part at the input to CHP and the demand side at the output of the CHP. The supply part includes the: load forecast, price forecast, information about consumption characteristic,



weather conditions, natural environment repository, water, fuel. At the demand side there is: supply network, energy market, consumer. The consumer and the energy market are the elements, which are the source of the feedback loop to the CHP plant. Thanks to this feedback the CHP plant can adjust its production strategy by the means of load forecast and price forecast. The list of the factors on the supply and demand side of the CHP is presented in the Table 3.

The elements at the supply and demand side are changing dynamically. In consequence the production process of the CHP plant is vulnerable to the influence of the environment. The solution to this problem is preparation of the production strategy based on the current forecasts, optimization techniques and experience from system operation.

Table 3. Supply and demand side of the CHP plant

Supply side	Demand side
Heat load forecast	Heat load
Electricity load forecast	Electricity load
Consumption characteristic	Consumer
Weather conditions	District heating network
Natural environment repository (emission allowances)	Electricity grid
Water	Energy market
Fuel	

## 2.2. How does it work together?

The research presented in the thesis, concerning the construction of the method for analysis, uses, as an application case, the physical system applied in the process of preparation of the energy production strategy. Therefore, in order to present the physical system and give some insight on the complexity of the system of problem, the process of the energy production strategy preparation is chosen as a central element. The system of problem is created from the physical system and the goals referring to the characteristic of the physical system which are not consistent with current characteristics of the system, hence they cause problems. Based on the information in previous point, there are three sections presenting the complete view of the system. The first section is the supply side, delivering all the conditions required to run the energy production process and to prepare the energy production strategy. The second section is the demand side, where the decision made in the strategy preparation is supplied and in the consequence also the generated energy. The third section, between two presented above, is the model of the energy generation system for the urban area. The model is a link between the energy production strategy preparation process and the technology of the energy generation. Operation of the technology process is the first major source of the constraints in the strategy preparation. The second source of constraints is the demand side with the energy market and the energy consumers.

The system presented on the (Figure 13) is linked with the main process of the preparation of the energy production strategy. The process starts in the elements presented on the left part of the Figure 13 and proceeds to the right side of the figure. The element showed at the bottom it is a focus on picture of the model, which is used in the strategy preparation process. The indication of the back flow, pointing leftwards, is the feedback of computation results back to the decision maker (DM) who is preparing the next production scenario.

The process of the production strategy preparation starts with the collection of data. The objective of the energy generation system is to fulfill the demand for energy. The demand is generated by the consumers through the direct contracts, long term contracts and the trading on the energy market. Concerning these factors, the collected set of data has to describe the demand for energy on delivery day. The collected set of data includes:

- Electricity load forecast
- Energy market price forecast
- Fuel price
- Weather data
- Heat load forecast

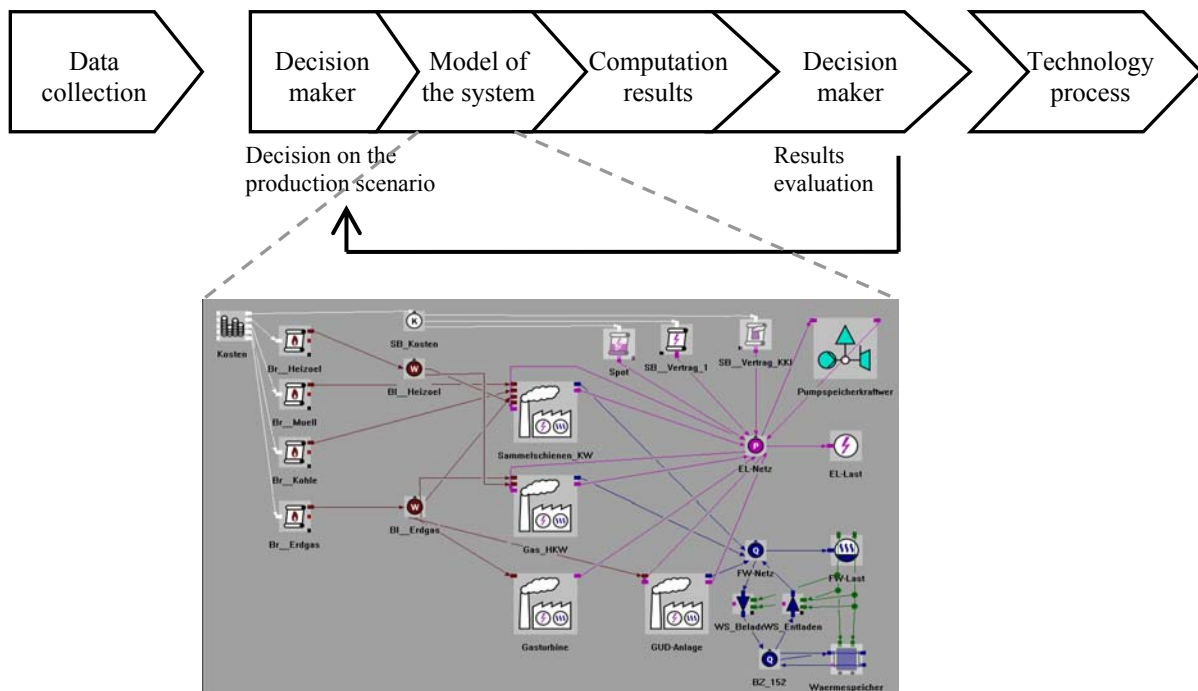

Figure 13. Energy generation system from the point of view of the system of the preparation of the energy production strategy

The collected set of data is organized into reports and put into database along with the records of the calendar meteorological data and historical configurations of the system. This is a starting point for the decision maker (DM) to start the preparation of the production strategy. The gathered data are used to set the energy load which will be produced on the delivery day. The energy load is presented in the form of time series with the amount of energy produced in every hour. At the CHP plant the load is split into electricity and heat load. For the estimation of the electricity load the most important is the electricity load forecast and the forecast of the price on the energy market. For the estimation of the heat load the most important is the heat load forecast and weather data. At the CHP plant, the heat and electricity loads are linked in the co-generation process. (Figure 14) This effect of synergy between two processes of heat and electricity generation makes the production strategy preparation more complex, but also puts the CHP into the more dynamic position on the energy market. The GENCO with the CHP plants can yield the profit from selling more electricity during the peak hours. Moreover the heat and power co-generation system has higher energy generation efficiency 85% comparing to the single heat generation process 70-

80% and single power generation process 36-40%. (Values according to The Polish National Energy Conservation Agency)

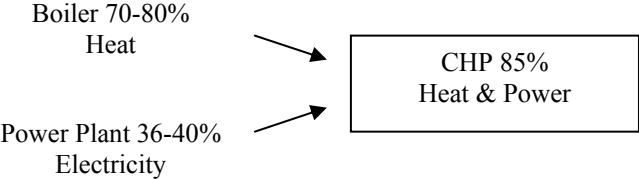

Figure 14. Synergy (Values of energy generation efficiency according to The Polish National Energy Conservation Agency)

The energy load set by the DM is a proposal based on the forecasts, reports from the decision support tools and experience of the DM. The proposal of the DM is formed in the production scenario which includes variants e.g. 10 variants. These variants are put one by one into the model and submit to the computation process. As the result from the BoFiT TEP (or alike software) the DM receives the expense of the generation of energy per energy unit i.e. €/MWh. This result is given in the time series e.g. for each hour of the delivery day. The result includes also all instructions about the setup of the energy generation system, necessary to produce the energy at the calculated expense. The DM analyzes the results and makes the decision to accept or not this production strategy. The cycle repeats starting from the DM’s decision about the energy load put into the model, until the results from the optimization of the production scenario are accepted.

The other point of view on the energy generation system, is the technology process. The presentation of the energy production process, presented below, shows the core production process where energy is the product of the sequence of processes. The scheme of the production process showed on (Figure 15) includes also the up and down stream stages e.g. mining, pollution emission, deconstruction, which do not take place on the site or in present time but are linked with the operation of the CHP plant.

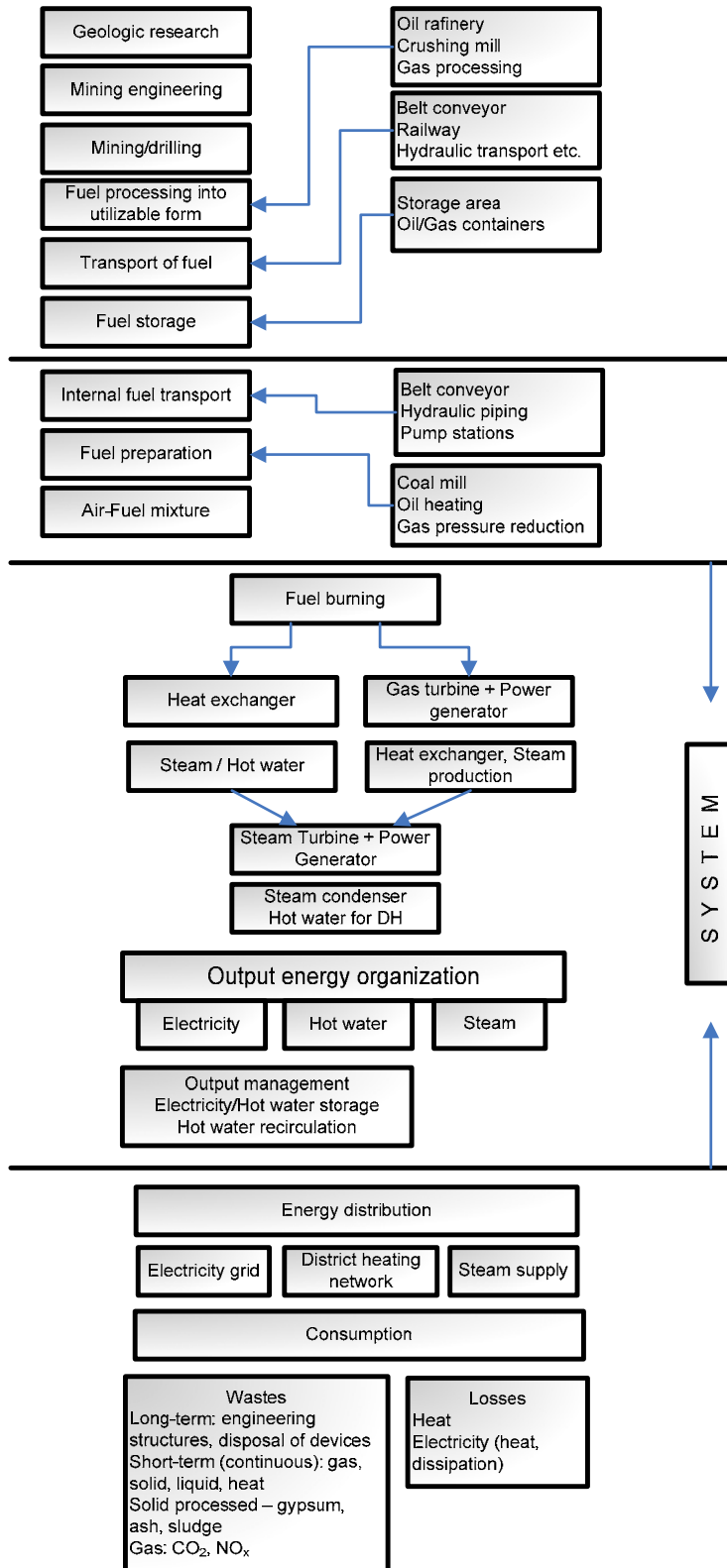

Figure 15. Energy production in the CHP plant – production process with example elements (DH-district heating)

### 2.3. Characteristic of the units applied in the system - example

The characteristic of the operation of the energy generation system depends on the type of the energy generation units applied in the plants. The solution used in the unit determines the operation parameters like e.g. operational power range, fuel, start-up, shut-down times. At the level of the technology of the heat and power generation, the problem which has not been solved yet is the continuous adjustment of the energy generating units to the dynamically changing demand. The energy generation units as e.g. boilers and turbines, they have their strictly described operation limits. The theoretical graph presenting the operational range of the steam turbine is presented on Figure 16. Operation of such a system, under the changing demand conditions, involves the shut-down and start-up operations, which increase the marginal cost of the energy and consume time.

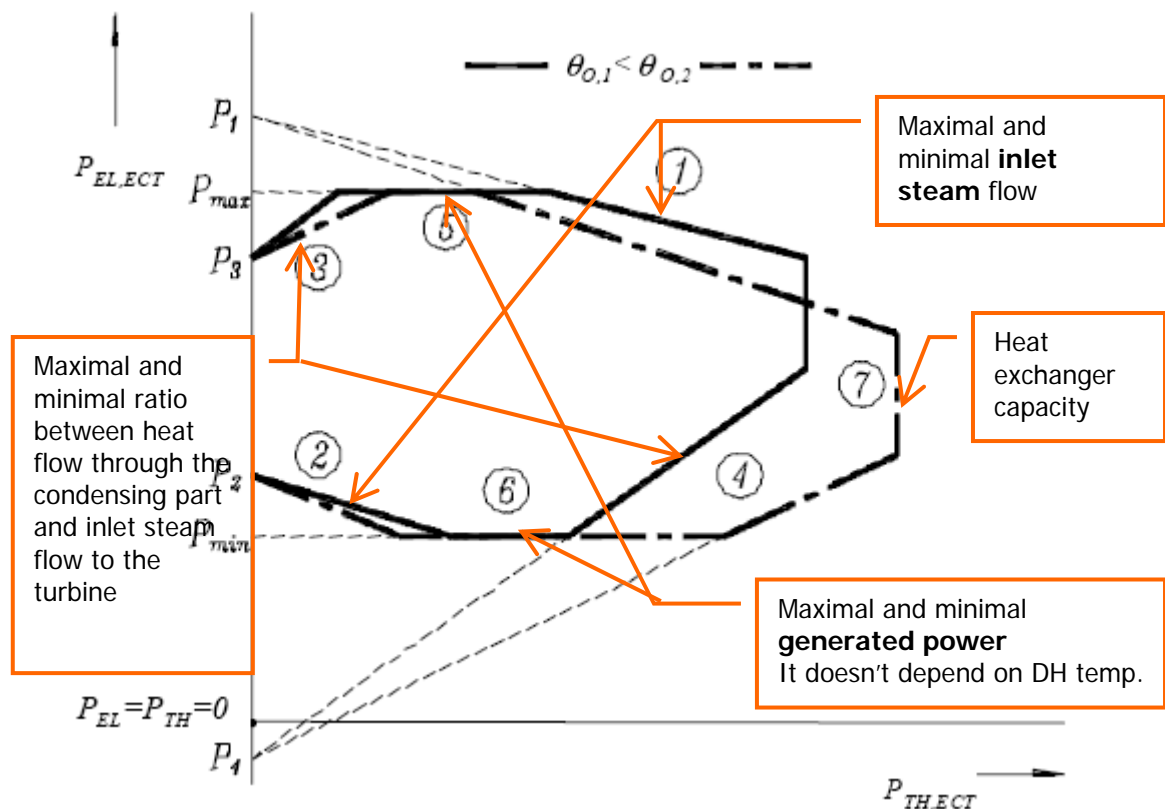

Figure 16. The feasible solution set for electric power and steam flow output. Condensing extraction turbine – set of operations modes. Operation at two different hot water outlet temperature levels is shown. The solid line represents a lower temperature level then the dotted line. (Thorin, Brand et al. 2001)

### 2.4. Synthesis

The preparation of the strategy of the energy production is linked with the technology process in the energy generation plants via the model of the energy production system for the urban area. The model includes all elements in the form of functions expressing the characteristic of the particular elements e.g. boilers, fuel supply, turbine.

### 3. Energy market particular solutions

In the conditions of the liberalized energy market, part of the energy produced at the CHP plant, in the form of electricity, is traded at the energy market, and more precisely, at the energy exchange. Generally two horizons of trading can be distinguished – long horizon and short horizon. Long term contracts can be also traded as the Over the counter (OTC) contracts, which are made on the exchange or outside the official exchange. On the market, the contracts are traded to secure future prices and current contracts (Spot Market) for the day-ahead delivery. The day-ahead market is also called the spot market. In the following presentation of the energy market and also in the presentation of the energy strategy preparation process, as an example of the trading scheme we use the day-ahead market.

In the intraday trading, a whole day is split into 24 separated markets, each for one hour. The transaction for this hour is based on the offer submitted to the network operator with a one day advance (Day-ahead market). System operator (Independent System Operator ISO) has an ability to regulate original power sources, this way he balances all the system in the 1sek horizons during the delivery day. Technical balancing market, on the side of the GENCO, works in the e.g. 1 hour ahead the responsibility of the operator. This 1 hour market is used by operator to balance the system. Market participants are submitting offers with price bids at which they are ready to change supply up or down.

#### Energy market – explanation of the general rule

Energy market is in many ways the real time market with the condition that demanded energy must be delivered in the very moment when demand appears, because there is almost no storage capability. The reason why the whole system has to be balanced in every second is the key limitation of the electricity that in fact it can not be stored and released later.

Considering the impossibility to separate physical from financial processes, there exist following structures of energy trading:

- obligatory trading on the spot market – with day ahead trading
- optional exchange of bilateral contracts (OTC) with different options of relation to the spot market
- Finally on the delivery hour it is the system operator who decides about utilization of the offer with its price.

The solution of the liberalized energy market introduces many opportunities. Thanks to the energy market and the software solutions like BoFiT we can deal with the complex situations like operation of the one company supplying two large cities. (Fröck, Jung et al. 2003) For example considering two, large, separated cities – heat energy is delivered to two separated heat networks, electricity is delivered to one common electricity network, both groups of utilities producing heat and electricity are united under single GENCO (mutual interest on the electricity market) e.g. Berlin and Hamburg (BEWAG before 2003, now Vattenfall Europe Berlin). Benefit from such operation is e.g. balance in the electricity generated in CHP plants in two cities and sold on the one energy market.

Expected in the future intensified introduction of the alternative energy sources and the solution of the distributed energy sources will decentralize the production of the energy. In order to deal with the new structure of the energy sources, it is expected that the trading period at the energy exchange will change from one day ahead to the one hour ahead.

(European Technology Platform, 2006) This increases the need for the quick decision making in the short period of time.

#### 4. Junction of the interests (UCED)

Customer load demands in electric and heat generation systems are subject to changes because human activities follow daily, weekly and monthly cycles. The load demands are generally higher during the daytime and early evenings when industrial loads are high, lights are on and so forth, and lower during late evenings and early mornings when most of the population is asleep. It is required to commit enough generating units to meet the load demands in electric power systems. In order to present the problem in the extreme way, the solution to fulfill the demand is to commit enough generating units to meet the peak load demand and keep these units on. In this way a brute force solution to generating unit schedule is provided. However, turning some units off when they are not needed, can save a great deal of expenses. The objective is to satisfy load demands while operating the power system economically. Unit commitment (UC) is the process of determining optimal schedule of generating units over a set of study period subject to device and system operating constraints. (Yamin 2004)

During the preparation of the energy production strategy for the GENCO, there appears the conflict of the interests between the technology and trading principles. The unit commitment (UC) planning is arranged by technology department with the principle of minimization of the overall system operation cost. The trading department has to set the economic dispatch (ED), which bases on the UC, but its objective is to minimize the total fuel cost consumed by units in operation with the constraints of the units and the system. (Jayabarathia, Jayaprakasha et al. 2005) The UC and ED have to be optimized for the same production strategy realized by the physical system of energy generation of the GENCO.

In order to find the solution to unit commitment economical dispatch (UCED) problem, the energy generation system of the GENCO is represented by the model. The DM uses the model to simulate the real operation and to compute the expense of the proposed UCED solution. Inside the UCED problem, the ED is a sub-problem of the UC. The UC is the main and the most complex problem in the UCED. (Wood and Wollenberg 1996) (*Chapter 3.9. p.57*)

#### 5. Dealing with the problem – solutions in computation and market

Approaches developed to address the preparation of the energy generation strategy have the origin in the initial problem called unit commitment (UC). The economic side of the UC problem is called economic dispatch (ED). Bind together these two problems are simply called unit commitment and economical dispatch (UCED). This problem has been addressed for many years as an optimization problem for the energy generation systems. (Fink and Galiana 1998) Recently the situation has been significantly changed. (See definition below) Introduction of the liberalized market for energy, made a significant change in the problems facing the preparation of the generation strategy for the energy plants. Following paragraphs present the approach to the UCED problem at the level of the computation algorithms, market solutions and also with categorization into solutions used before the energy market liberalization and after the liberalization of the energy market.

Liberalized energy market – is an energy market with working with the rules of competition between energy producers. The term often used with the market liberalization is the market deregulation which in basic form means the suppression of all regulations from the governments. Then the price of energy is decided by the market forces. However there is a need to keep some regulations in order to protect the consumer rights, keep anti-trust rules and increase efficiency. This is why the terms of market liberalization and deregulation are often interchanged.

## 5.1. Before energy market liberalization

The unit commitment problem in the energy generation appears as a consequence of a need to decide how many units have to produce energy in order to fulfill the energy load. The amount of the energy load is declared by the energy demand. In the particular case of the energy demand in the municipal area, the energy load is split into heat load and electricity load. Knowing the energy load which should be produced for the consumer, the energy generating company (GENCO) has to decide how to allocate this load to the energy generating units in the company. The problem with the allocation of the energy quota has a few reasons.

- Energy generating units have different energy output and different efficiency of energy generation (Efficiency as a ratio of output energy e.g. electricity measured in kWh ( $3,6 \cdot 10^6$ J) to the energy at the input e.g. heat measured in MJ)
- Energy generating units have different start-up and shut-down times when they consume energy but they do not produce their nominal output.
- Energy demand changes throughout the day thus there is a need to adjust the total energy production.

Because of these reasons it is uneconomical for the GENCO to run all the time the units required to fulfill the demand. The unit commitment is the plan which units should be run at which time of the day in order to provide the reliable source of energy. The problem of unit commitment including also the economical consequences of the operation of particular units is formulated as an optimization problem. (Nayak and Sharma 2000)

The economic part of the UCED problem is Economic Dispatch. Dispatching of the energy takes place when the energy generation units have been already committed to work under the unit commitment plan. The objective of the economic dispatch is to find the optimal combination of active power in order to minimize the production cost. The production cost can be defined here as the total fuel cost. It depends on the demand balance, technical limits of the production units and energy production system constraints. (Roa-Sepulveda and Herrera 2000)

In order to find the optimal production schedule, the UC and the ED are simultaneously performed in a combined form. UCED is a problem addressed by many optimization techniques. There are also several methods which mix optimization techniques in order to obtain the better performance on the different stages of the minimization. Thanks to the combination of optimization techniques the optimization process advances faster towards the minimum. Various approaches to the solution of the thermal unit commitment problem have been proposed. Review of the optimization techniques presented in (Yamin 2004) shows the following classification:



1. Deterministic techniques
  - Priority list
  - Integer/mixed-integer programming
  - Dynamic and linear programming
  - Branch-and-bound method
  - Lagrangian relaxation
  - Security constrained unit commitment
  - Decomposition techniques
2. Meta-heuristic techniques
  - Expert system
  - Artificial neural networks
  - Fuzzy logic approach
  - Genetic algorithm
  - Evolutionary programming
  - Simulated annealing algorithm
  - Taboo search
  - Hybrid techniques

Selection of the technique to solve the UCED problem depends on the structure of the particular system of energy generation in GENCO.

## 5.2. After energy market liberalization

For a long time, since the creation of the energy generation systems with multiply generation utilities and common supply grid, the UCED problem has been solved by the means of optimization techniques. With the deregulation of the energy market the spot price is no longer predetermined but it is set as a result of the energy market competition. The GENCO faces then the situation where it is still required to solve the UCED problem. However the price for energy is settled through the open competition during the market session, where GENCO places a bid based on the production strategy including UCED solution. Therefore the price is known only after the market session and it is not known during the preparation of the production strategy and UCED solution. Therefore the price should be forecasted. The objective of GENCO is then to make the maximum profit. It is a radical change comparing with the minimization of expenses before liberalization. This can no longer be achieved by selling the energy at high price because the competition can bid a lower price and thus win the contracts. The maximization of the profit for GENCO can be realized by production of energy at low cost and winning more contracts. (Song and Wang 2003) These is the theoretical solution because it is also possible to trade larger contracts outside the market auction thanks the OTC (Over the counter) bilateral contracts. In this situation, the real competition takes place on the spot market.

The preparation of the production strategy for GENCO in the deregulated energy market includes two aspects, the solution of the UCED problem and the arrangement of the energy trading. Both aspects are linked by the physical system of energy production and fact of the impossibility of energy storage. The complete optimization of both problems for each trading session is impossible because of the limited computing power and time. Therefore the scenario analysis method is applied in order to examine the prepared series of production

scenarios realizing the particular concept of energy generation and trading. (Kaleta, Ogryczak et al. 2003) The scenarios are composed out of variants which are optimized by the production strategy preparation software e.g. BoFiT software family. The result of the optimization is the price per energy unit generated in the proposed production scenario for each calculation period e.g. each hour of the 24h delivery day. The other part of results is the configuration of the energy generation system to realize this production strategy. Decision about the eligibility of the production strategy, which is a result of the computed variant, this decision is made by the human decision maker.

In the scenario analysis process, decision maker uses the help of the decision support tools. The individually designed software solutions help in the forecast preparation. Decision maker applies also risk management concepts like ‘value at risk’ (VaR) and ‘profit at risk’ (PaR).

### 5.3. Solution in the computation algorithms

The problem in the scheduling of the energy generation system in the liberalized market conditions, including the UCED problem, is a large scale nonlinear mixed integer problem (MIP). (Sun, Ma et al. 2005) The mathematical solution of the MIP is a time consuming task, therefore the progress in the solver algorithms reduces the time consumption. Recently more systematic procedures based on variety of algorithms have been proposed and tested (Hobbs, Rothkopf et al. 2001):

- dynamic programming
- branch-and-bound mixed integer programming (MIP)
- linear and network programming approaches
- Benders decomposition (marginal cost based MIP solution method)
- Metaheuristics
- genetic programming
- simulated annealing
- expert systems
- neural networks

The solution which has been the most successful, and which is most widely used at present, is Lagrangian relaxation used for the optimization in the MIP problems. The approach used in the lagrangian and the augmented lagrangian to the solution in generation scheduling and transmission is presented in (Lan, Luh et al. 1994; Wang, Shahidehpour et al. 1995).

### 5.4. Solution in the market organization

The GENCO is an entity owning energy generation units and participating in the market with the sole objective of maximizing its profit, without concern for the system for energy distribution unless there is an incentive for it e.g. CHP plant and the DH. Therefore, the GENCO’s operational planning activities depend on the market structure in which it is operating. (Bhattacharya, Bollen et al. 2001)

In the pool market (Bhattacharya, Bollen et al. 2001):

24-hours ahead (day-ahead):

- price forecast is available estimating the hourly market prices for next day,
- based on its generating unit characteristics, unit availability, ramp rate, etc., GENCO determines a bidding strategy for each bidding period next day e.g. 1 hour contracts, block contracts.

In real time:

- Perform generation strategy according to the instructions from the ISO.

In bilateral markets (Bhattacharya, Bollen et al. 2001):

24-hours ahead:

- A price is available estimating the hourly market prices for the next day.
- Using the price forecast as input, the GENCO determines its UC, generation schedule and trading decisions for the next day. At the same time GENCO has to meet its bilateral contract commitments and maximize its profit from the energy market.
- Based on its trading decisions and price forecast GENCO determines the bidding strategy for each bidding period during the next day e.g. 1 hour period, peak hours, morning etc.
- Submits the decided dispatch schedule to the ISO.

At time periods near real-time:

- Monitors the system conditions, monitors balance market prices, utilization of updated forecast of the balance market prices.
- Formulate bidding strategies for the balance market as appropriate.

In real time:

- Fulfils generation commitments to bilateral contract customers and day-ahead commitments.
- Fulfill the balance market commitment if bid is selected.

## 5.5. Synthesis

The process of production strategy preparation includes the computation process in order to solve the optimization problem. The optimization problem is solved by the means of mathematical algorithms. The approach in the algorithms has changed in the past and evolved in order to deal with the new opportunity for the GENCO, which is the trading of the energy contracts on the liberalized energy market. The problem in the production strategy preparation is to manage the UCED and energy trading options inside single production strategy. The production at the GENCO should be arranged to use the maximum opportunities from trading on the energy market in order to maximize the profit of the GENCO.

## 6. BoFiT – example procedure incorporation

The operation of the energy generation systems has to deal with many constraints e.g. start-up times, computing power. These limitations are not linked to any particular GENCO, therefore the solutions to deal with these limitations can be applied in many companies. As the solutions are developed into more complete suits and commercialized. There exist many solutions produced by the specialized companies e.g. GE, ProCom, ABB and then sold to the GENCO.

In order to have an access to the real data about the existing solution in the preparation of the energy production strategy for the urban area, we have acquired for the research purpose, the one of the recognized commercial solutions named BoFiT TEP produced by ProCom GmbH. This solution, in the form of software, was supplied for the purpose of our research thanks to the ProCom GmbH in Aachen, Germany. The BoFiT-TEP included also real models of the energy generation systems for two anonymous German cities.

BoFiT TEP is a part of a larger procedure, the energy management system (EMS) including: BoFiT TEP, data acquisition and process visualization component (Helios), tools for load prognosis and long distance heating nets operation. (Kohlmeier, Ressenig et al. 2003) BoFiT TEP is designed to realize the final step of the preparation of the energy production strategy for the following day. The most popular application is the optimization of the model in the BoFiT TEP in order to get the production strategy for the following day in order to use the results in trading at the day-ahead energy market.

The procedure applied in BoFiT TEP has the following purpose (Kohlmeier, Ressenig et al. 2003):

- to support the application of the software to the particular system
- optimization of cooperation with the energy market
- arrangements of energy quota
- general and specified expenses model for city energy production system

BoFiT TEP is designed to produce the energy generation strategy in the following time horizons:

- day ahead,
- short time horizon i.e. from 15' to several hours,
- long time horizon i.e. from 1 year to several years (used for business development decision, fuel arrangements).

One of the advantages of the BoFiT in the analysis of the urban energy generation system, is the idea of the integration of the distributed system of energy sources, into the one virtual heat and power generating plant. The distributed system using different sources, including the increasing role of the alternative sources, is integrated by the means of BoFiT. The effect is the virtual energy generation plant. Integration into virtual plant and into the national energy system, by the means of traded energy contracts, provides the significant savings. (Stock and Henle 2002)

## 6.1. BoFit TEP – The structure

Explanation of the key names used in the text:

BoFiT	– software family, energy management system, made by ProCom GmbH
BoFiT TEP	– software for daily operation optimization and portfolio management
CPLEX	– library of mathematic programming optimizers made by ILOG
ILOG	– experts in object-oriented programming and algorithm development
ProCom	– service provider and engineering company

BoFiT TEP is a software, energy management system specialized in daily operation optimization for GENCO. For optimization tasks it employs the CPLEX solver, provided by the external party ILOG. Therefore, talking about the utilization of BoFiT TEP, it should be specified which of the partial tasks are realized by which component. In order to distinguish the CPLEX solver from the BoFiT TEP main frame, it is proposed to name two main components as BoFiT kernel and CPLEX solver. (Figure 17)

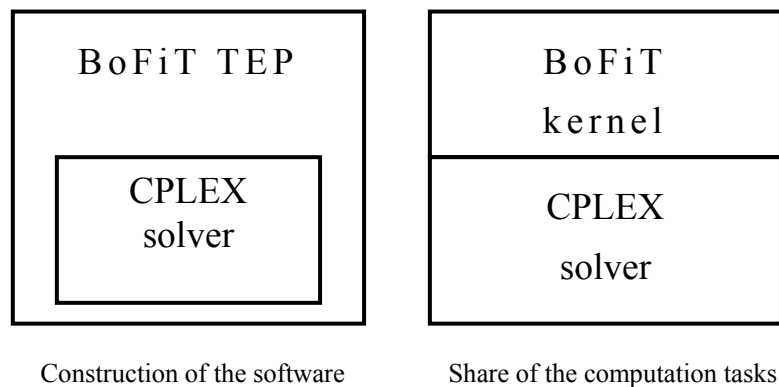

Figure 17. BoFit – relation between engines

The distinction between the tasks realized in the BoFiT kernel and the CPLEX is important as the CPLEX is a module used in the BoFiT TEP and it can not be modified.

### BoFiT TEP – The model

BoFiT TEP is designed to find mathematically optimized solution to the problem described as Unit Commitment and Economic Dispatch. (Wood and Wollenberg 1996) This problem is originated in the real system of energy production. In order to represent the system of energy generation and describe in mathematical form the problem of preparation of the production strategy, there is a need to build a model. The model is built via graphical interface in BoFiT TEP. Process of the model construction is presented on Figure 18.

Firstly, the static part of the model is created. Static part is built one time and modified only when necessary e.g. in case of the introduction of the new piece of equipment. The dynamic features are put into the model and are being actualized in each computation session in order to bring the model up to date for the particular situation conditions.

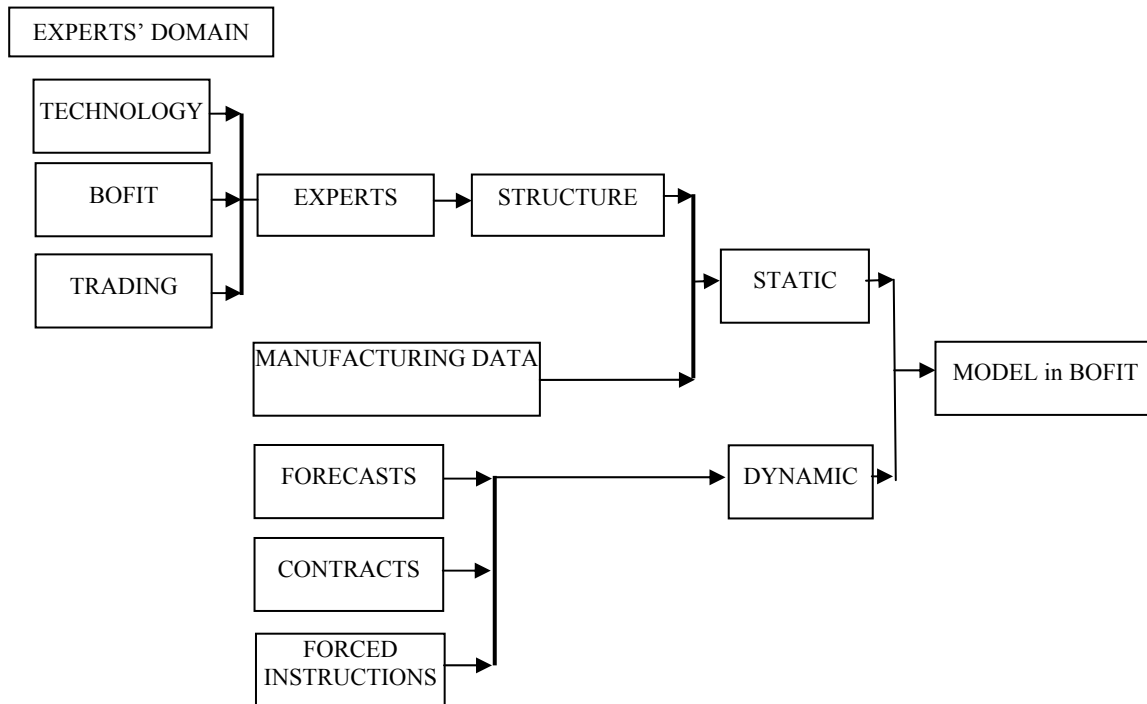

Figure 18. Creation of the model (model with data for current situation)

Apart from static and dynamic categorization, the model may be described as algorithm and data. Where algorithm is a structure developed by experts and data are parameters like manufacturing data, forecasts, contracts etc. When the model is complete, the algorithm with the updated set of data, the calculation may start.

### BoFiT kernel

For the computation the model of the system is presented as a mixed integer problem (MIP). The formulation of the problem as the MIP has following advantages (Icking, Lucht et al. 1994; Sun, Ma et al. 2005):

- energy quantities are represented in real variables,
- integer (or binary) variables are allowed e.g. on/off conditions,
- description of constraints, the MIP is also a compromise between model accuracy and solution efficiency.

Comparing the MIP with other methods of strong combinatorial capabilities e.g. discrete dynamic programming does not handle complex systems with co-production, storage, transport constraints. The nonlinear subgradient methods allow building more sophisticated models comparing to the MIP, but they are inefficient for large systems with many generation units. An additional advantage of the MIP is that, there are many commercial solvers for MIP problems. (Icking, Lucht et al. 1994)

A complete MIP is set up out of partial models of all system components. These specific data about the system are formed by BoFiT kernel into the mathematical optimization problem in the shape of the matrix (Table 4). BoFiT kernel simplifies the matrix only to some extent, i.e. it substitutes some variables. (See point 3.1. in (Icking, Lucht et al. 1994)). Most of aggregation is done by CPLEX solver. After the computation the results from CPLEX get interpreted and de-aggregated by the BoFiT kernel and presented in the graphical interface.

## CPLEX Mixed Integer Optimizer

Before the solution in CPLEX the large matrix is aggregated. In order to give the idea of the size of the matrix and the result of the aggregation, (Table 4) presents the number of rows and columns in the matrix before and after the aggregation.

Table 4. Size of the matrix before and after aggregation (Tegeler 2005)

	Original MIP	Reduced MIP
Rows (=constraints)	61 691	19 042
Columns (=variables)	64 589	26 505
Matrix nonzeros	191 600	67 764

CPLEX Mixed Integer Optimizer provides the capability to solve problems with mixed-integer variables (general or binary) using linear or quadratic objective function. It utilizes state-of-the-art algorithms and techniques, including cuts, heuristics, and a variety of branching and node selection strategies. CPLEX Mixed Integer Optimizer also includes a sophisticated mixed integer preprocessing system. Thanks to CPLEX it is possible to solve large and difficult integer problems quickly and efficiently. (CPLEX is made by ILOG Inc.)

The most calculation time is spent on solving the reduced matrix. After the computation the solution to the mathematical problem is delivered by CPLEX solver and interpreted by BoFiT kernel.

## 6.2. Components used in the model

The model of the energy production system for the urban area is constructed using the graphical interface in BoFiT TEP. (Figure 19) The presentation of the example elements and the groups of components available in the software, will help to understand the construction of the model. The groups of components with the description of their function and example of the component are presented in the Table 5.

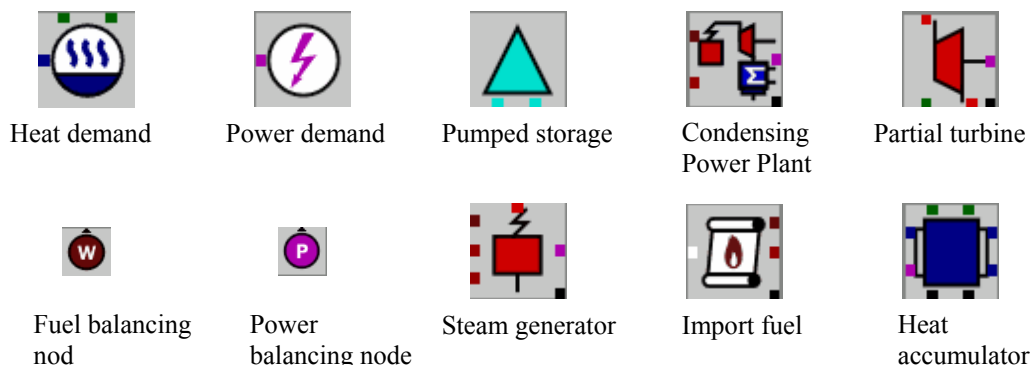

Figure 19. Example of the graphical symbols used in the model in BoFiT TEP made by ProCom (ProCom 2005)

Table 5. Component groups in the BoFiT TEP (ProCom 2005)

(Abbreviations used in the table: DH – district heating)

#	Name of the group	Function	Example elements included into the group
1	Main components	Basic technology elements to arrange the system of power station / CHP	Turbines, partial turbine, condensers, steam generators, pressure reduction station
2	Limiters	Limiting the flow, additional cost	Limiters for heat, water, steam, current, thermal output
3	Balance nodes	Connection of flows of one medium, measuring nod (results in these points show the optimal utilization of particular production lines, optimal flow distribution, in the form of time series)	Balance fuel, balance steam, balance power
4	Import contracts	Transformation of money into e.g. fuel	Fuel contracts, electricity contracts, thermal output
5	Energy Sale	Transformation of energy into money.	Sale fuel, sale electricity, sale steam
6	Gas and steam plants	Technology elements to construct the schema of the gas energy plant.	Gas turbine, auxiliary firing, heat recovery boiler
7	District heating restrictions	Technology elements to model the heating network.	Parallel supply, DH-Mix node
8	Accumulators	Technology elements to model the accumulators.	Heat accumulator, fuel storage, water, pumped storage
9	Unit models	Blocks of basic units integrated into the one element	Condensing power plant: steam generator + steam turbine + condenser
10	Supply components	Technology element representing the product's receiver.	Supply DH-Network, Supply Steam, Supply Power, Supply Fuel
11	Component relations	Relation management e.g. sets the limit when the operating scheme should be changed.	Control band, operation relation, firing relation
12	Value derivatives	Relation management, generation of the decision impulse basing on the flow of the medium and related flow e.g. calculation of the necessary values for the supply level relation	Gauge heat, gauge steam, gauge fuel, gauge power
#	Name of the group	Function	Example elements included into the group
13	Trading components	Comprise the standard power exchange products.	Base, peak, night, morning, hourly power exchange, rush hour
14	Temperature	Introduction of the temperature impulse calculated from two different temperature	Temperature profile
15	Connectors	Connection of the elements	Fuel, start-up fuel, steam, power, control power, heat dissipation, thermal output, sweet water, costs

In the model there are used different colors in order to distinguish the flows described at position 15 in Table 5 above e.g.: fuel in brown, steam in red and heat in blue. (Figure 20)



The change of the flows e.g. from fuel to steam flow takes place due to the stages in the energy production process presented in the model.

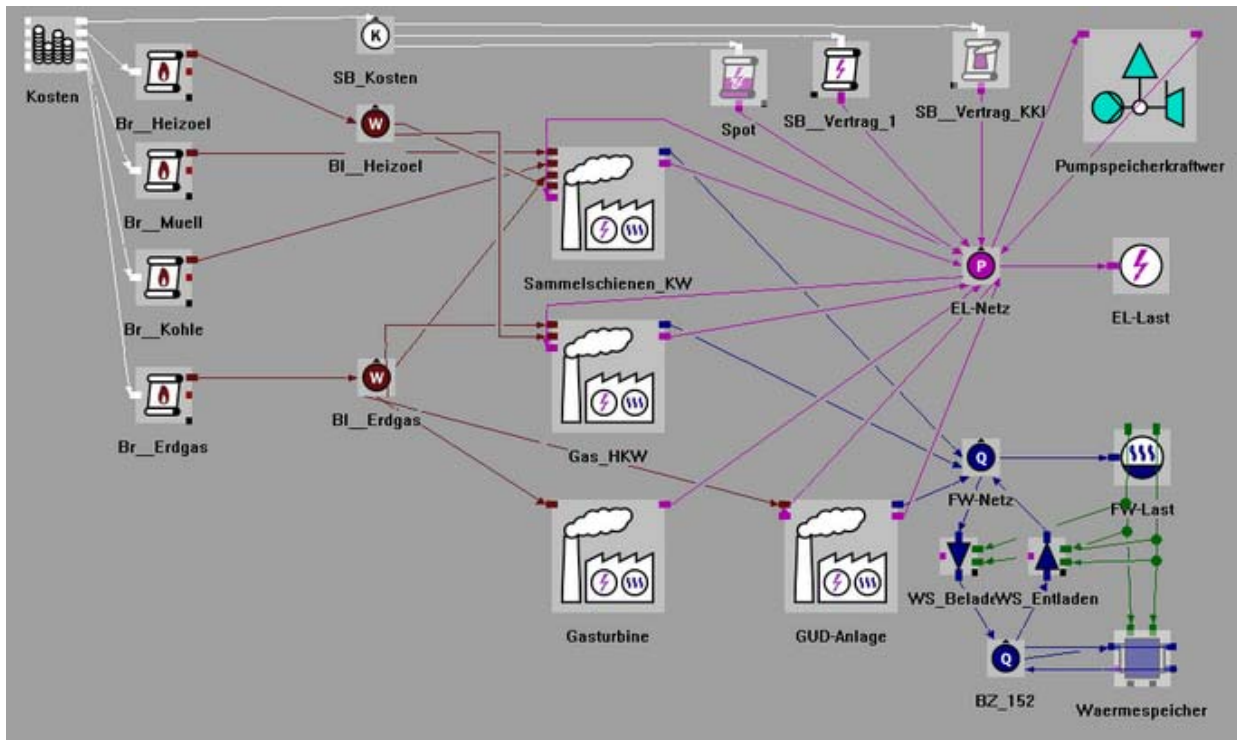

Figure 20. A view on the top level of the model in BoFiT TEP

### 6.3. BoFiT – setup of an element in the model

Elements used to construct the model are modules supplied in the BoFiT TEP. They include the function written for each element and embedded into the particular module e.g. heat accumulator. Below in the Table 6 there is a list of parameters which are required to describe the heat accumulator in the BoFiT TEP.

Table 6. Parameters required to set up the heat accumulator in BoFiT TEP (ProCom 2005)

Connection	Type	Abbreviation	Unit	Direction of the connection
Thermal input	Mandatory	QZ	MW	in
Thermal output	Mandatory	QA	MW	Out
Own power consumption	Optional	PE	MW	In
Thermal Output for Temperature Modification of Feed Water	Mandatory	QS	MW	In
Flow Temperature	Mandatory	TV	°C	In
Return Temperature	Mandatory	TR	°C	In
Load Operation	Optional	EA	-	Out
Unload Operation	Optional	EZ	-	Out

## 6.4. BoFiT – constraints

The result from the optimization of the model of energy generation system depends on the space left in the abstract solution area. The abstracted solution area is restricted with the constraints described by the functions of the model's components. Each constraint is a load for the optimization solver and it increases the computation time. The goal of the optimization of the model is minimization of total operation costs for combined production of heat and power. The list presented below, shows the example set of constraints. These constraints are put in the model in the corresponding modules and integrated into their characteristics.

Example of the constraints present in the model (Icking, Lucht et al. 1994):

Steady-state network constraints:

- energy balance for the electrical network including pumping water consumption,
- energy balances for DH-transport nets,
- spinning electrical reserve requirements,
- hydraulic heat transport capacities.

Steady state plant and contract constraint:

- technical operating conditions of plants and their components,
- cost structures of energy and fuel purchase contracts.

Dynamic plant constraints:

- minimal operation-line and off-line times,
- maximal speed of power output variation,
- storage balances,
- startup, shut-down times.

User definable constraints:

- boundary conditions e.g. Given schedule at the beginning,
- fixed commitment decisions e.g. Must-run or must-not-run,
- temporary bounds e.g. Limitations caused by cooling water conditions.

## 6.5. Synthesis – information about BoFiT

In the research on the construction of the method for analysis of the complex system, the BoFiT TEP solution is used as a case presenting the real procedure of the preparation of the energy strategy. Thanks to the ability to explore and operate the real model in the BoFiT TEP software it was possible to efficiently proceed with the analysis applying the analysis tools. The BoFiT TEP was used firstly to explore the model and components of the energy generation system. Secondly BoFiT TEP was used to collect information about the particular solution to the preparation of the production strategy used in this product.

## 7. Operation of the model in BoFiT

The one of the main elements of the production strategy preparation process is the operation of the model of the energy production system. This model, available for the research purpose from ProCom GmbH, is operated in the BoFiT TEP software. The standard operation of the model includes:

- Construction of the model,
- Edition of the model,
- Setting up the data for the model computation,
- Computation with the optimization algorithms,
- Interpretation of the results.

In order to learn about the model's operation in the BoFiT TEP it was necessary to run the model several times. Setting up and running the computation gives an opportunity to closely observe:

- the configuration of the model representation of the real energy production system,
- elements required to model the system,
- relations between elements of the system,
- data required to setup the model,
- the way to read and analyze results after the model computation.



---

## Chapter 3. Analysis tools – classification

---

The presentation of the physical system in Chapter 2 had an objective to show the structure of elements included into this system. The physical system of the process of preparation of the energy production strategy has several properties which make it complex and thus difficult to analyze:

- it is composed out of several smaller systems e.g. decision making, computing, production technology,
- elements of the system are influenced by the dynamic factors e.g. changes in the energy load, spot price of energy
- number of elements and relations between elements is high i.e. the example can be the number of functions and arguments necessary to describe the system in the example model it is 20'000 columns, 60'000 rows with 5-10% of non zeros.

When we start to describe the initial problem – see Chapter 4 – the physical system is a basis for the creation of the system of problem. The system of problem is developed gradually by the analysis of the problems when their description becomes more detailed. The problems in the system of problem have the relation to the physical system. The complexity of the physical system has the influence on the complexity of the relations in the system of problem. For instance - in the system of problem we want to describe the reason of problems and the relation between different problems. In order to do this it is necessary to refer to the relations in the physical system.

Construction, development and analysis of the system of problem without any tools are time consuming and they risk not considering the key issues. The systematic approach to the set of interrelated problems facilitates the construction of the system of problem and gives the guidelines to analyze it in search for the solution. The purpose of this thesis is to propose the method composed out of several analysis tools which will address problems in the system of problems. At the same time it should manage the application of analysis tools and the obtained information. Thanks to the application of several tools, the method will be better adjusted to the problems analyzed in the system of problems, comparing to the utilization of a single analysis tool.

The analysis tools presented in this chapter will be applied in the construction and analysis of the system of problem. The process of the application of these tools is presented in the following Chapter 4. Categorization of the analysis tools presented in the Table 7 uses the information about the tools in order to classify them as method, technique or concept. The table includes also information about the place where the particular analysis tool was used in the analysis process. This information is known only when the analysis is being performed. However it is premature to present this here, it is considered as important information and presented in Table 7 along with the general classification of the analysis tools.

Before the application of the analysis tools to the analysis of the engineering problem, there is a need to present and describe them. The analysis tools are listed using the classification according to the level of their organization e.g. concept, technique, method.

As it was mentioned above, Table 7 includes also a note, made for each tool, indicating the area of application in the process of analysis of the system of problem. It is important for the analysis tool to be applied to what it was designed for. Indeed when the application is made for the different purpose, then the analysis tool does not deliver an intended result. Therefore, in order to apply properly the already defined analysis tool, it has to be applied for the purpose that it was designed for. Afterwards the result of the correct application can be used to conduct the research in other direction, not necessarily the one which had been intended in the tool's design, but the tool itself was applied properly. For instance, the language of problem representation designed for the communication with experts can be used for the representation of the problem based on the information collected from various sources. This representation helps to discuss the priority of the presented problems. Then, instead of the improved communication with the experts, user achieves the improved understanding of the data which he/she has collected.

## 1. Classification of analysis tools – introduction

The analysis tools, applied further in this document, are taken from various methods. They are collected during the problem analysis when they are chosen to satisfy the current need. The classification of the tools is necessary, in order to know what part of the larger entity is applied e.g. is it a technique or a module. Analysis tools, which are in use during the analysis process come from different origins, they are smaller or larger parts of various larger analysis tool packs. The type of the particular analysis tool has to be defined in order to apply this tool to the task which it is designed to. The application to the problem, in accordance with the class of the tool, will use the potential of the tool and fulfill the expectations.

### Concept

Concept is a formulation of an observation which captures some part of reality. Concept captures some pattern from the observation of the system or process. This pattern can be used to better understand the process, or to search for the presence of the same concept in other systems, processes. In order to make a use of the concept, the technique has to be constructed, including elements inducing the action in the process to apply the concept.

### Rule

The rule is the prescribed guide to conduct the action. The rule describes the action and says which elements should be used in which order or configuration. It arranges the utilization of the concepts and models by giving the instruction how to perform the action in order to use the properties of the models and concept.

### Model

Model, in terms of components of the analysis tools, is a unit which has a fixed structure. The model is used as a set structure in order to facilitate the understanding of group of data and

facts. In order to make the model utilizable in the analysis of the particular object, the model should be updated with the data referring to the current analysis. Model does not perform an action itself, it is used along the rules and it is a part of the technique.

### Technique

Technique is a set of actions performed in the particular order returning as a result new information about the analyzed object. The technique is formed from the models, concepts and rules. The general objective of the technique is to transform the object of analysis in order to obtain required information. Information obtained as a result is new, it was not known before the application of the technique. The technique is designed to make an analysis of the selected sort of objects described in the instruction of the technique. The technique may describe also the way how to present results e.g. graph representation of some relations, set of key problems or new point of view on the analyzed element.

### Method

Method is constructed from the techniques, procedures and rules. The method has a main structure, which is static. The application of particular techniques is coordinated by rules. The rules decide which technique is used at a time. Decision on the utilization of more techniques in border of the method, is based on the results from the previously used technique. Decision is made following the rule specified in the method. The method is designed for a precise objective and has a defined form of a result. However inside the method there are several ways to achieve the objective by application of different configuration of techniques.

## 2. Classification – conclusion

The relation between described analysis tools: method, technique and module can be presented as a hierarchy. The method includes one or more techniques and the technique includes the modules. These relations are the super-system, subsystem relations. The method is a super-system. The subsystem of the method is the system of techniques. The system of modules is a subsystem of technique. (Figure 21)

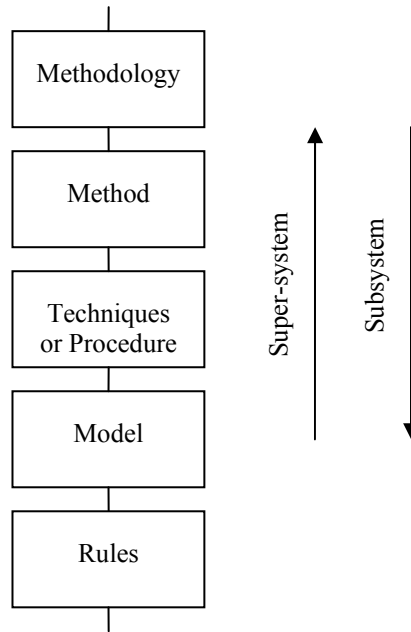

Figure 21. Relation between method, technique and module

### 3. Classification of analysis tools and the field of application

Table presented below (Table 7), lists all the analysis tools we used for dealing with the practical problem presented in Chapter 2. These analysis tools were the basis to construct the method proposed in Chapter 4. The analysis tools in the table (Table 7) are arranged according the classification presented above in paragraph 1. Additionally the table includes also, for each tool, a note indicating where this tool is applied in the analysis of the system of problem presented in the next chapter, Chapter 4. The place of application is described as follows: define the question, gather information and resources, form hypothesis, conduct experiment, gather data from experiment, draw conclusion.

#### Laws of technical system evolution

Laws of the technical system evolution are a concept created as a result of observation and generalization of the regularities appearing in technical systems evolution. The TRIZ theory includes the formulation of laws of the evolution of technical system. The concept of laws of the technical system evolution is an important part of TRIZ. Laws are the one of three basic groundings which the OTSM-TRIZ is based on. As the laws of technical system evolution are the concept, they can be used in the technique as a concept driving the application of the rules and models in order to examine particular element.

Some of the laws of technical system evolution will be applied inside of the method for analysis of the system of problem. The purpose of their application here is to recognize the relations between the elements and to explore new elements and new relations in the system. The technique applying the concept of the laws proposes to analyze the input, output and flows in the energy generation process.



Table 7. Classification of the applied analysis tools with the description of the area of application (AA – application area)

Method	Technique, Procedure	Model, Rules, Concepts
Method for the system exploration <i>Application area:</i> (forming hypothesis, gather information and resources), search for the problems in the system and the relations between elements	Pace of development in different parts of the system; AA: gather information and resources	Concept: Law of irregularity of system's parts evolution
	Level of development analysis (macro>micro level)	Organization into Super-system, sub-system (rule); Concept: Law of transition from macro- to micro-level
	Harmonization analysis; AA: gather information and resources, forming hypothesis	Law of Harmonization (Concept)
	Energy flow analysis; AA: gather information and resources	Energy flow diagram (Model), Law of energy conductivity in system (Concept)
	Construction of the Multi Screen Scheme of thinking; AA: gather information and resources	
Analysis of initial situation conditions (AIS) <i>Application area:</i> (define the question, gather information and resources) analysis of the initial situation conditions, verification of the standard solution existence.	By-pass <i>Application area:</i> search for the acceptable alternative solution.	Contradiction (Model)
	Size Time Cost operator (STC) <i>Application area:</i> overcoming the mental inertia	Contradiction (Model)
		Quantitative characteristics
	Analysis of life cycle <i>Application area:</i> description of the problem on the time line	Working conditions, manufacturing conditions

Method	Technique, Procedure	Model, Rules, Concepts
ARIZ-85C <i>Application area:</i> (define the question, form hypothesis) destined for the resolution of non standard problems,	Problem redefinition <i>Application area:</i> (define the question) intensification of the problem definition,	Contradiction (Model)
	Multi Screen Scheme of thinking (technique and concept) <i>Application area:</i> (define the question, gather information and resources, gather data from the experiment) organization and guidance of the thinking process	Model: Screen, sub-system, super-system
	Step back analysis <i>Application area:</i> (gather information and resources) search for the original problem, solved by the solution.	Contradiction (Model)
	Construction of the network of problems <i>Application area:</i> (gather information and resources , form hypothesis) overall understanding of problem situation (big picture), complex cross-disciplinary problems.	Rules how to arrange problems and partial solutions, how to connect them.
	Construction of the network of contradictions <i>Application area:</i> discovery of further problems, concentration on key problems, (gather information and resources , form hypothesis)	Model of contradiction including evaluation parameter
	Construction of the IDEFØ graph <i>Application area:</i> (gather information and resources) designed to model the decisions, actions, and activities of an organization or system, discussion with experts.	Model of the box (box with connectors: inflow, outflow, control, mechanism), Concept of the IDEFØ
	Construction of the causal loop diagrams (CLD) <i>Application area:</i> (gather information and resources, form hypothesis) description of relation between elements of the system, support in information collection	Variables, polarized links, delay, model of archetypes, rules how to connect the variables, how to use links
	Construction of the stock and flow diagrams <i>Application area:</i> (form hypothesis, gather data from experiment) modeling of the system or selected parts of the system, dynamic representation of the system	Stock, flow, relation links, models of archetypes, rules how to build the diagram

## 4. Synthesis

For the construction of the method of the analysis of the system of problem, it is relevant to define the category of the particular analysis tools. The analysis tools should be applied with the objective and in the research area, which they were designed for. The misapplication leads to poor or no effects. It has been observed that some analysis tools are know in the form of the technique e.g. construction of the Multi Screen Scheme but it is better to perceive them at the level of the concept applied in the technique. Then this concept can be used in the technique constructed for the particular need which matches our need.



---

## Chapter 4. Construction of the method

---

The construction of the method starts with the initial problem identified in the engineering system. The analysis of the initial problem explores and defines the system where the problem appeared. This process, of initial problem analysis, applies the basic techniques and models e.g. model of the problem expression in the form of contradictions. The objective of this introductory analysis is to describe the system. In the result the analysis method gathers the great number of data, which needs to be easily operated in order to make them utilizable. The organization of the data is introduced progressively by utilization of the techniques like e.g.: AIS, Bottleneck analysis, production process analysis. After the initial stage and the system definition, there is enough data to describe the main elements of the system and the concerned process. Finally, the collected output from the application of the analysis tools is presented in the form of the graphs and networks, which manage the entire view on the system and problems.

### 1. Initial problem – engineering system

The initial problem is usually the first description of the problem which is submitted by the user or expressed in the form of need. The supplementary description of the initial problem creates the basis for the further analysis which leads to the construction of the system of problem.

#### 1.1. Initial problem presentation

The initial problem, in the engineering case, marks the starting point for the creation of the analysis method. The initial stage of the analysis has an objective to gather the data in order to describe the system and define the problems. Knowledge about the elements of the system and relations obtained from the analysis tools are gathered and organized in the tools which help to guide the analysis and then operate the entire system of problems recognized in the analyzed system.

### 1.1.1 Initial problem – high time consumption

The initial problem, in the form presented below, was given by the ProCom GmbH company, as the example of the real problem in the complex engineering system.

An initial problem, in the system for PSt production, was described as follows: ‘Too much time (expressed in seconds) is consumed by the computation process.’ In the existing solution, for a medium sized model, the time of computation for a day-ahead PSt is 180s. The satisfactory solution of this problem, described by the ProCom company, should have 1/100 of the current time consumption, in this example case this is 1,8s.

Table 8. Time expense distribution in the computation process

STAGE:	LICENSE	TIME [s]
Matrix setup	BoFiT kernel	90
Simplifications	BoFiT kernel	15
Aggregation	CPLEX	5
Solution	CPLEX	155
De-aggregation	BoFiT kernel	-
Results interpretation	BoFiT kernel	15

*Values in the table are computed for the different example case then the 180 second example.*

The problem of time consumption due to the computation is caused by the computation element, the subsystem to scenario computation (element#2 S3L2 in Table 17). Computation process includes 6 elements. Among them it is the solution in the solver, which consumes the 55% of the computation time. (Table 8) The time in the solver is consumed by the algorithms searching the near optimal result. It is desirable to spend more time to have the result closer to the optimal, but at the same time it is desirable to spend less time for computation in order to be able to run more new alternative scenarios, variants. The time for computations and decision is limited e.g. 1 hour. The possible solution of the parallel computing is not introduced because the cost of single computing server is too high. This problem is expressed in the form of contradiction, which is shown as a graph on (Figure 22). The desired solution is marked by two (+) parameters standing for the positive (desired) value of the parameters P1 and P2.

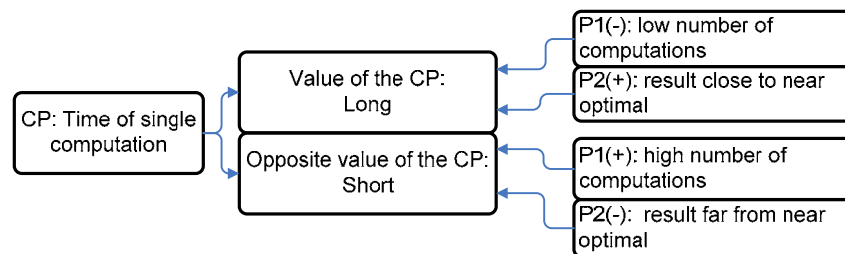

Figure 22. Time of computation – contradiction

### 1.1.2 Number of data

Following the formulation of the initial problem above, the immediate question posed using the rule from OTSM-TRIZ is - Why the time of computation is long? The answer is - Because there is a great number of data in the matrix set for the computation. The matrix contains the constraints functions and the arguments. Each constraint more in the matrix means the increase in the computation time. Moreover the relation between number of constraints and the computation time is exponential. This fact increases the importance of the number of data in the matrix set for the computation. Constraints and arguments in the matrix come from the model, the preset element of the scenario computation. The model contains the mathematical representation of the real system for energy generation and trading. Functions building the model say how all elements are working one by one and how they are connected together.

The goal is to have less data in the matrix while maintaining the quality of the PSt at the output. The need for less data is directly linked with the computation time, by exponential dependence and it can be measured in the same way as time consumption. If we consider that there is applied the same solver for different computation, the computation time can be used as a measure for the number of data. The reduction in data number can be evaluated by comparison with the model containing the maximum number of data. As it is expressed in the contradiction (Figure 23), the desired solution should deliver an accurate PSt and reduce the computation time. The accuracy of PSt is described as a difference between the PSt from model with reduced number of data and the model with maximum number of data. The PSt received from the modified model is considered as accurate when the difference in results is in range of  $2 \div 2,5\%$ .

There is a need to have the high number of data in order to produce the accurate PSt and at the same time there is a need to have low number of data to have short time computation. This contradiction can be also expressed with the parameter closer to the sources of the problem, the number of constraints. (Figure 23)

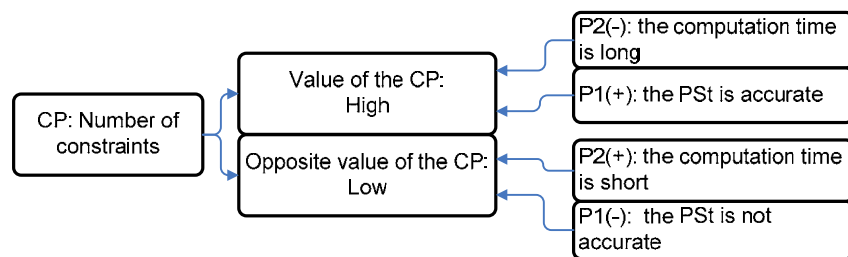

Figure 23. Number of constraints – contradiction

The problem of the number of data is already treated by two elements of the computation system, the simplifications and the aggregation. The simplification works on the elements of the matrix (functions and arguments) with the reference to their function in the model e.g. simplification of two boilers into one, whereas the aggregation treats the data strictly mathematically (aggregation algorithm).

### 1.1.3 Knowledge capitalization

The shortly presented description of the initial problem of time consumption and closely linked problem of data amount has already induced the organization of the knowledge. The systematization of the knowledge realizes here three objectives:

- It provides the picture of the analyzed problem and of the results from the analysis.
- It links the problem with the knowledge in the database – in this document database can be referred as information about the physical system in Chapter 2.
- Guidance for further exploration – in order to expand the description of the system of problem there is a need to apply further tools. The schemes presented below show the guideline and organize the exploration.

#### Multi Screen Scheme of Inventive Thinking (called Multi Screen Scheme or System operator)

System operator it is a scheme built basing on the concept of linking the same levels of the system along the transformation of complex system in time. In the scheme the system is positioned in the relation to its super-system and subsystem. (Altshuller 1988) The super system is a system containing the system. The subsystem is a system which is a part of the system. These terms describe the relations starting on different levels i.e. element described before as a super-system has its own super-systems and subsystems. The function state of the systems changes within time. This fact adds to the scheme the second axis, axis of time and definition of before and after systems. The scheme can be also extended to contain an anti-system, system with the contrary function, which is pictured in the background of each element. (Figure 24)

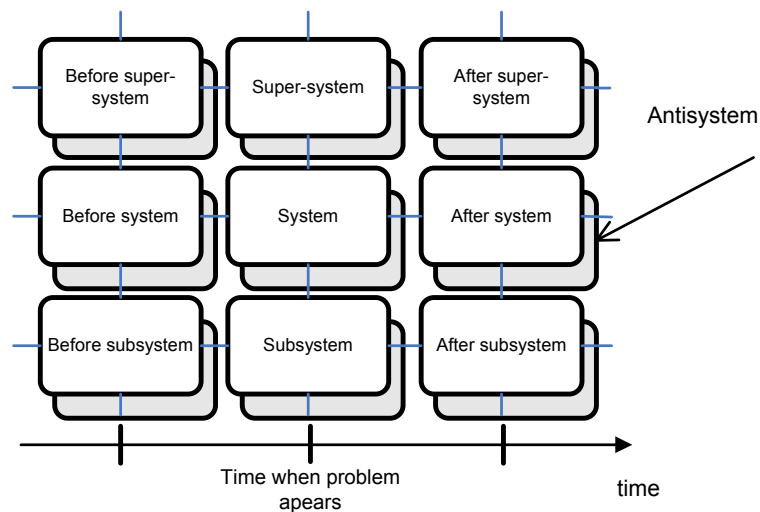

Figure 24. Multi Screen Scheme of Inventive Thinking – description of the concept (Altshuller 1988)

The system operator is used to organize the thinking process and to guide it. It is not designed to present relations in the system because the structure of the scheme depends largely on the researcher's need to make an instant picture of the thinking process about the situation currently under research.

The multi screen scheme (system operator) presented on (Figure 25) shows the relation between the time consumption load associated with amount of functions with arguments put in the model. The elements responsible for problem of time consumption and data amount are



localized in the timeline of the decision making process. Thanks to the same scheme they are presented as a fragment of the structure of the system for energy production strategy preparation process.

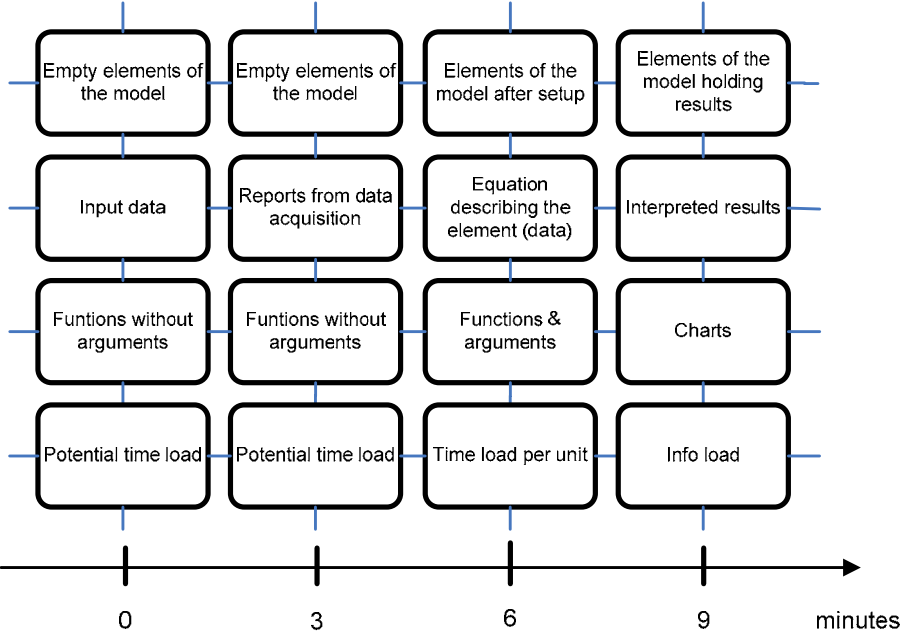

Figure 25. Multi Screen Scheme of Inventive Thinking (System operator) – time consumption load and data amount

IDEFØ

The graph built based on the concept of IDEFØ is used to represent the elements of the system not necessarily directly linked by the sequence of any process. This concept allows putting on the one scheme elements from different regions of the system, from different levels of hierarchy. The basic model used in the IDEFØ concept is a box containing the name of a function. The box has 4 edges named: input, output, mechanism and control. The links from other boxes are linked according to these 4 profiles. (Figure 26)

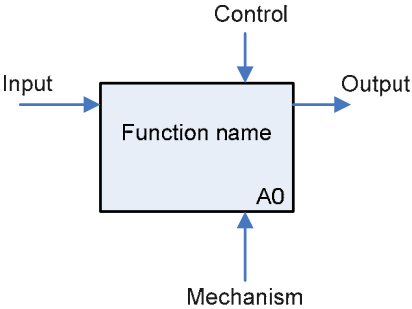

Figure 26. IDEFØ concept – model of the function box

The IDEFØ scheme presented on (Figure 27) shows a single box with function of ‘Scenario computation’s and links linked to this box. This box will be accompanied later with other boxes to present the scheme of functions identified with the system of energy production strategy preparation. (Figure 27)

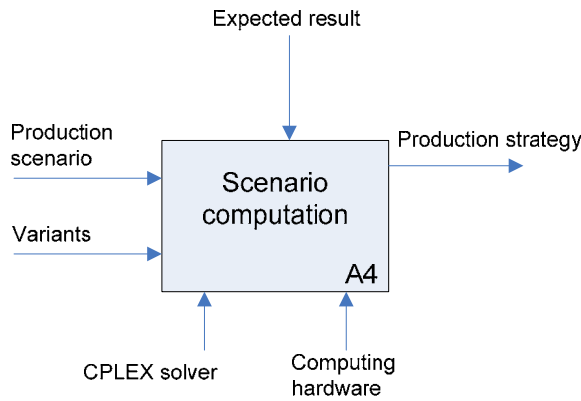

Figure 27. IDEF0 scheme – Function: ‘Scenario computation’

### CLD

Causal Loop Diagram (CLD) shows the relations between variables. Relations are polarized in order to show that a variable has a positive (in accordance) or negative (contrary) influence on the other variable. For example, plus mark (+) on the link from A to B says that rise in A causes rise in B and also decrease in A causes decrease in B, the accordance. In the contrary action, marked by minus mark (-), the rise in A causes decrease in B and decrease in A causes rise in B. The construction of the diagram is based on the concept of the loop. In this way it is possible to observe the feedback action.

The CLD scheme presented on (Figure 28) shows the relation between amount of data and time consumption inside the process of the energy production strategy preparation. The causal loop constructed for this problem fits the archetype of CLD called ‘Limit to success’. Important information to understand this CLD is the limitation of the total time when the calculation can be performed. The loop on the right is a balancing loop (B mark). The more data we put at the input, the more time is consumed on single computation. The more time is consumed, the less data we can put into the model. This is because with longer single computation, less computation cycles can be made in the total time e.g. 1 hour and then less input data passes through the model.

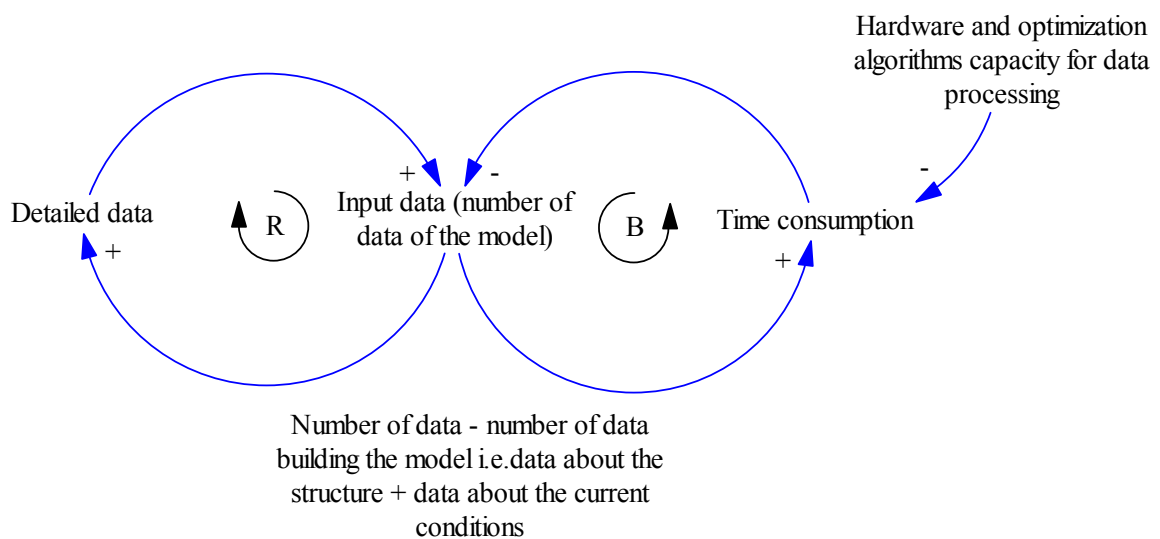

Figure 28. CLD Number of the data – Archetype: Limit to Success

### Network of problems

Network of problems is a concept from the OTSM-TRIZ. The network of problems can be built during the analysis of the problem. It shows the links between the identified problems, the problems which are the reasons and problems caused by the partial solutions to the problems. Partial solution solves only the part of the problem hence they causes further problems. The network of problems is used:

- to store information about the problems and relations between problems and partial solutions,
- to look for the root problem,
- to look for the key problems,
- to explore the system network of problems by identification of the problems caused by the applied partial solutions.

The scheme of the network of problems (Figure 29) shows the boxes with name of problems, gray background and boxes with partial solutions (PS), white background. The links between problem box and partial solution box says – to this problem the following partial solution has been proposed. Link from partial solution to the problem says – this partial solution causes following problem. Some partial solutions can be skipped in order to build the network quicker directly to concerned problems.

The (Figure 29) presents the fragment of the network of problems. Complete network of problems constructed for the problem analyzed in the thesis is presented in Appendix 3.

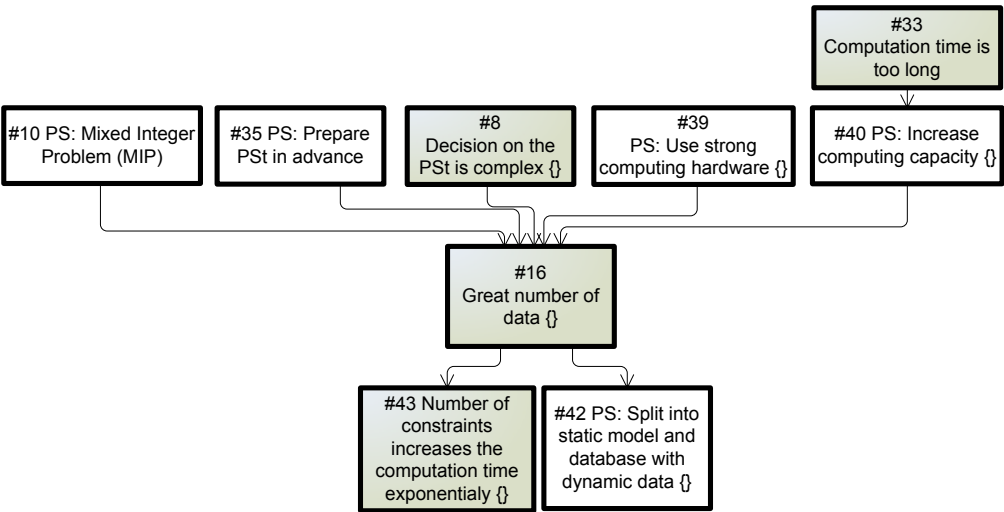

Figure 29. Network of problems – fragment

### 1.1.4 Synthesis

The description of the initial problem is a starting point in the analysis of the system of problem. The utilization of the knowledge capitalization tools in the early stages of the analysis helps to maintain the control on the process throughout the analysis. The analysis tools with the objective of knowledge organization like e.g. Causal Loop Diagrams, Multi Screen Scheme (System operator) and IDEF0, these tools can be used in parallel with the developing analysis of the system. The construction techniques used in these tools provide

also the support in guidance of the analysis process by pointing out what kind of information are necessary to describe the problem or system's element.

## 1.2. Problem exploration – ARIZ Part 1

The exploration of the system of problem continues with the application of the technique using the elements of the part 1 of ARIZ-85C (Algorithm of Inventive Problem Solving). (Altshuller 1956-1985) The applied elements include: formulation of the technical contradictions, intensification of the contradictions and the reformulation of problems.

In order to form the base for the system of problem it is proposed to use at the beginning the 'why' question asking for the reason of the identified problem. For instance, the problem of the time consumption and exact results is formulated as follows: 'Why it is difficult to obtain an exact result in the short time?' Formulation of further 'why' questions leads to the description of an initial group of problems in the form of contradictions – see the following point below. In order to move further with the analysis of problems we propose to identify the process in the physical system and to follow it adding more details to the system of problem.

### The 'Why?' question.

Why it is difficult to obtain an exact result in short time? Following this question it is possible to form the list of the factors, which have an influence on the precision of the result:

- Quality of the solver (optimization algorithms):
- Utilization of the simplifications in the model
- Number of the parameters
- Quality of the forecast

### 1.2.1 Contradictions

The mark  $\rightarrow\leftarrow$  is used as a symbol of contradiction.

The following sequence of contradictions presents the thinking path about the problem of computation time, amount of data and the precision of the result. This question is approached in 3 ways presented in the form of contradictions. (Figure 31, Figure 32, Figure 33) In result, the descriptions of these three contradictions are overlapping. In order to improve the description of the problem with computation and data amount, in the following point, it is proposed to look closer on the process where the computation takes place.

#### Hypothesis

There exists a minimum group of parameters, which allows obtaining a calculation's result close enough to the real value using the smaller set of data then in the currently applied solution. In the entire group of parameters prepared for the energy production plant, there are parameters, which can be skipped. When these parameters are not included into the

calculation, the accuracy of the result does not change or it changes in the acceptable range. (Figure 30)

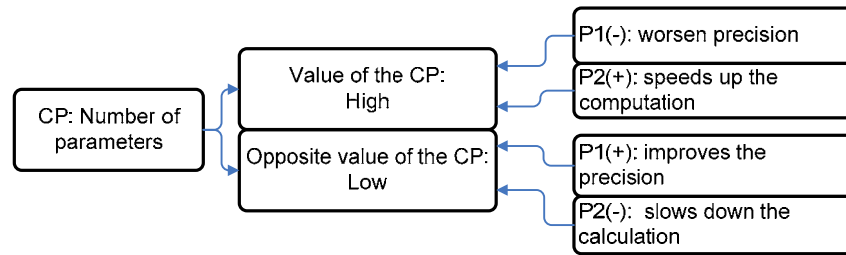

Figure 30. Contradiction – Number of parameters

→← Contradiction: Computation time

We would like to obtain a result quickly because it saves time, but we would like to obtain a result not so quickly because then the result is closer to the real value. (Figure 31)

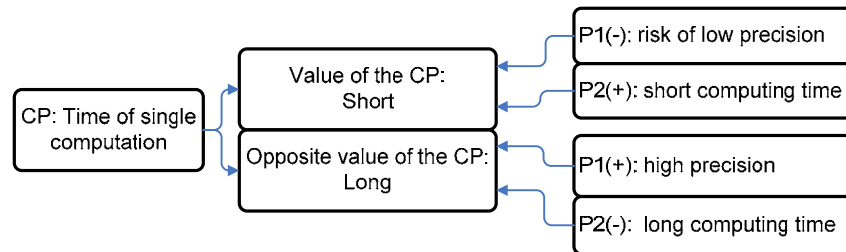

Figure 31. Contradiction: Computation time

→← Contradiction: Computation result's precision

We would like to have rough calculation because they consider small amount of data and we would like to have fine calculation in order to have high precision. (Figure 32)

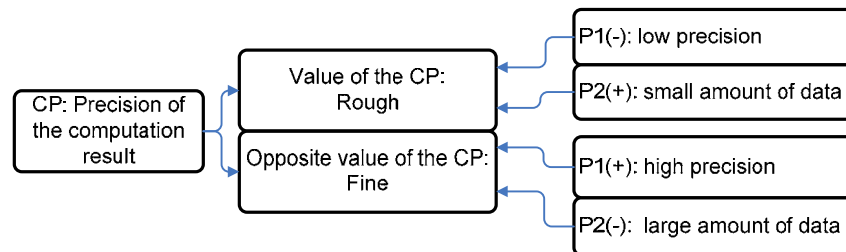

Figure 32. Contradiction: Computation result's precision

→← Contradiction: Amount of data

We would like to consider all data in order to always receive a result close to the real value but we would like to consider a limited amount of data in order to obtain a result in shorter time. (Figure 33)

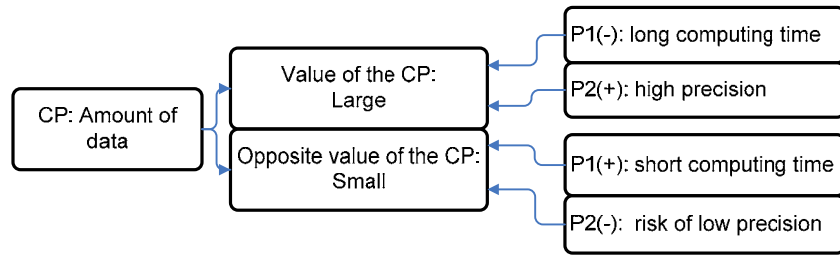

Figure 33. Contradiction: Amount of data

## 1.2.2 Introduction of process's schemes

In order to continue the analysis of the system, it is proposed to describe the process, which takes place in the physical system of PSt preparation. During the progressing analysis it turned out to be necessary to describe three points of view on the process, from the general view described at the beginning to the more focused one at the end.

The first diagram shows the general view on the computation process. (Figure 34) According to the initial problem this process consumes too much time.

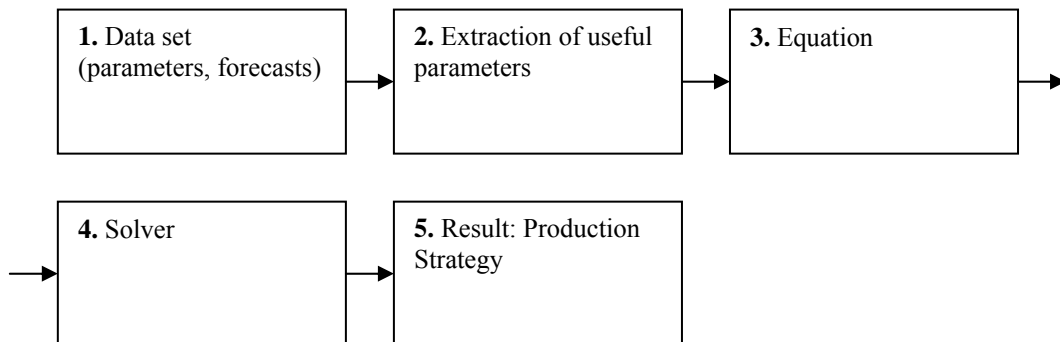

Figure 34. Structure of the calculation process

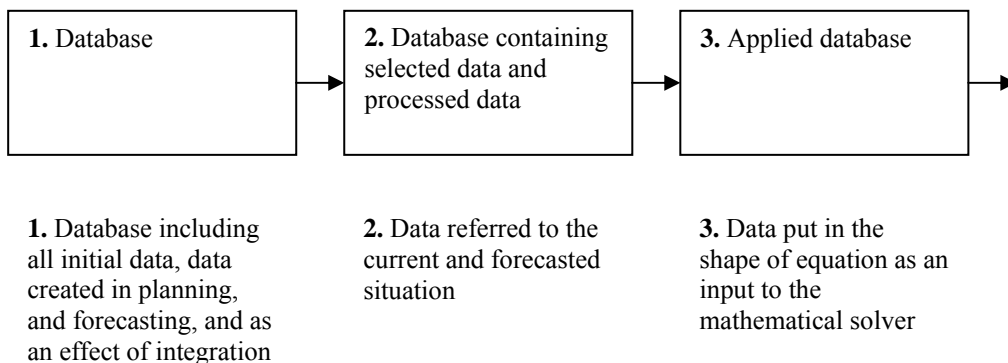

Figure 35. Database transformation

In order to reduce the time of the calculation of the result, the only accessible elements are the input data. The input data are transformed in the following process: first there is a database with all available elements, then database with selected elements and at the 3<sup>rd</sup> stage the equation, which may be called an applied database. In the applied database data are put into the structure of model forming the matrix of equations and variables. (Figure 35)

The time consumption in the computation process is generated by the solver. The simplified view on the computation process is presented on (Figure 36).

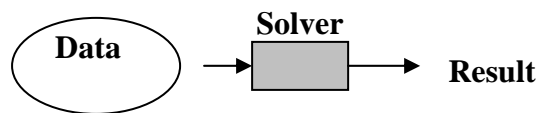

Figure 36. Data processing

Solver – an element, which is here a not modifiable processor of data. (Compare Chapter 2 point 6.1) When the parameters of the solver are unchangeable, the solver computing time can be influenced only by the amount of data and the requested form of the result. Result has a form of the production strategy. The only element to modify is the set of input data.

The conventional approach says that maximum amount of information is required in order to receive the result, with the high probability and close to the real value. We would like to have many data in order to have maximum amount of information and we would like to have few data in order to have them manageable. (Figure 37) The data are manageable when it is easy to estimate the result, e.g. for human it is easy when the amount of data is relatively low:

- number of data low enough to make calculation in memory
- number of data low enough to make written down calculation

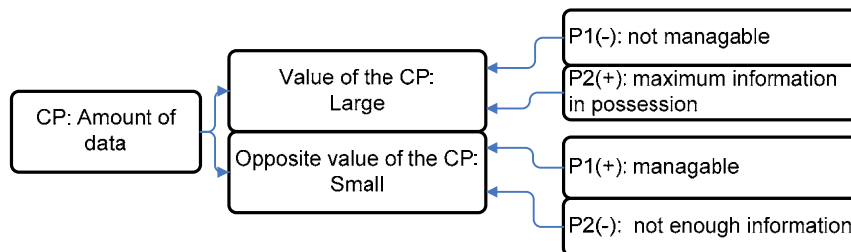

Figure 37. Data amount – contradiction I

According to the hypothesis, there is a minimal set of data, which after the computation returns the same quality of result. Following this assumption, the data can be divided into groups, significant data and insignificant data. Significant data are essential to reach the good result and the group of insignificant data causes a waste of computing time.

Why is it difficult to sort the important and not important data:

- Removal of many insignificant data may cumulate the result error and exceeds the acceptable error limit.
- An insignificance of data may be temporary for the particular situation.
- An insignificance of data may be temporary for the particular iteration and become significant after certain iteration.
- Relations between data are nonlinear.

We would like to have low number of data in order to have lower total number of data and then less insignificant data, and at the same time we would like to have high amount of data in order to have more of significant data.

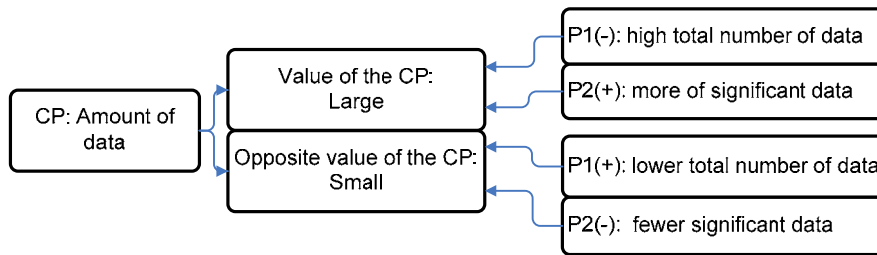

Figure 38. Data amount – contradiction II

### 1.2.3 Position of the CHP in the urban energy generation system

The initial orientation in the system of problem is already made by means of the analysis of initial problem. In the next step the analysis method uses the view on the system from the super system level in order to learn about the influence of the environment where the system for PSt preparation works. (Figure 39) The analysis enters the technology process in order to gather the constraints and learn about the particularities of the energy production process. The analysis tools are used also to describe the PSt preparation process itself.

In the system analysis presented below, the simple analysis tools are at use. However, they are guided by the processes taking place in the energy production system and the relations in the physical system.

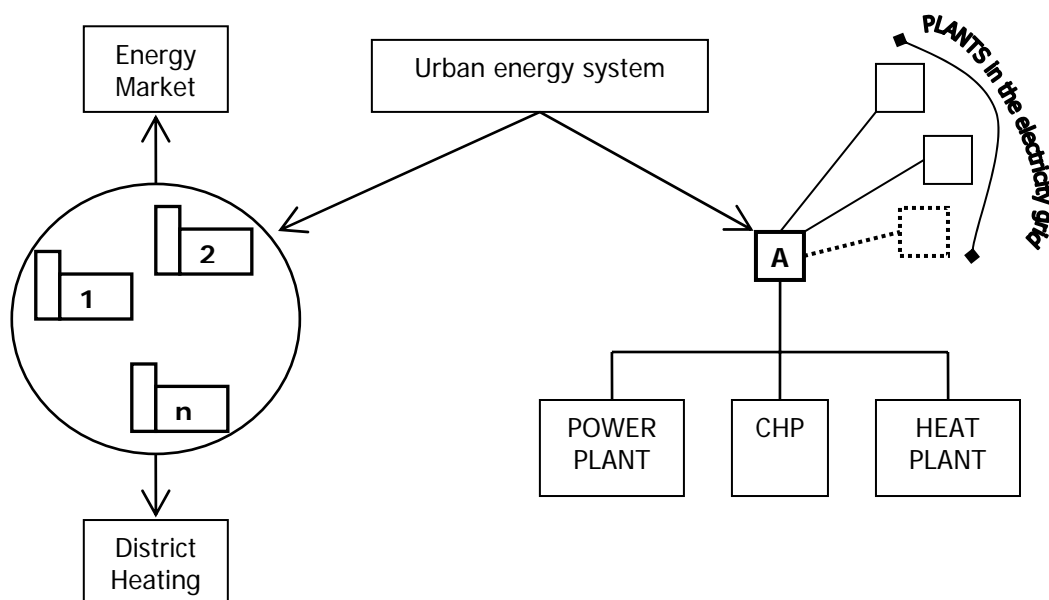

Figure 39. Urban energy system



Analysis of the position of the CHP in the urban energy production system – collection of observed options:

- Cooperation with the partner plant i.e. concerning the heat energy, CHP plant in the same DH network or concerning the electricity, the CHP is linked by the national grid to other energy generation units.
- The energy output of the GENCO is regulated by such utilities as auxiliary boilers and gas turbines, when there is a need for heat, steam production or electricity.
- Energy storage e.g. heat storage, water pumped storage stores electricity in the form of potential energy of water stored in the elevated basin.
- Recirculation in the DH network e.g. In order to move a heat consumption peak and produce more electricity in this time, the hot water from the supply pipe is mixed with the return water in order to rise its temperature.(Icking, Tröster et al.)

The three contradictions presented below, show the problems identified in the technology process of the energy production, in the urban energy production system, referring to the localization of the CHP plant.

→← Contradiction 1

Energy production units (power plants and CHP) have to be large (have large power) and centralized in order to be economic in production, services (centralization), controllability of the pollution and at the same time have to be distributed and not large in order to shorten the distance of energy transportation.

→← Contradiction 2

Energy production units have to be close to the energy sources to shorten the fuel transportation (infrastructure) and have to be close to consumers to shorten the electricity transportation (infrastructure).

→← Contradiction 3

Energy production units have to be close to the consumers to shorten the electricity delivery distance and to increase the production efficiency by selling the heat and at the same time energy production units have to be distant from the consumers to not pollute the urban area.

#### 1.2.4 The process of the production strategy preparation – BoFiT procedure

The initial problem of the high time consumption is located in the computation process. Computation process is a part of the PSt preparation process. The analysis of the process of the energy production strategy (PSt) preparation in the version applied by the BoFiT software, helps to identify the limitations of the procedure. This procedure has features common for the BoFiT software and this group of software solutions.

The procedure of the PSt preparation is performed two times. First time, with several iterations, the PSt preparation takes place one day before the delivery. (Figure 40) It is here where the initial problem appears. After the trading session at the day-ahead market, the PSt is generated again for the contracted values of the energy load. (Figure 41) The second preparation of the PSt does not have time limitations and does not cause a problem with the time consumption.

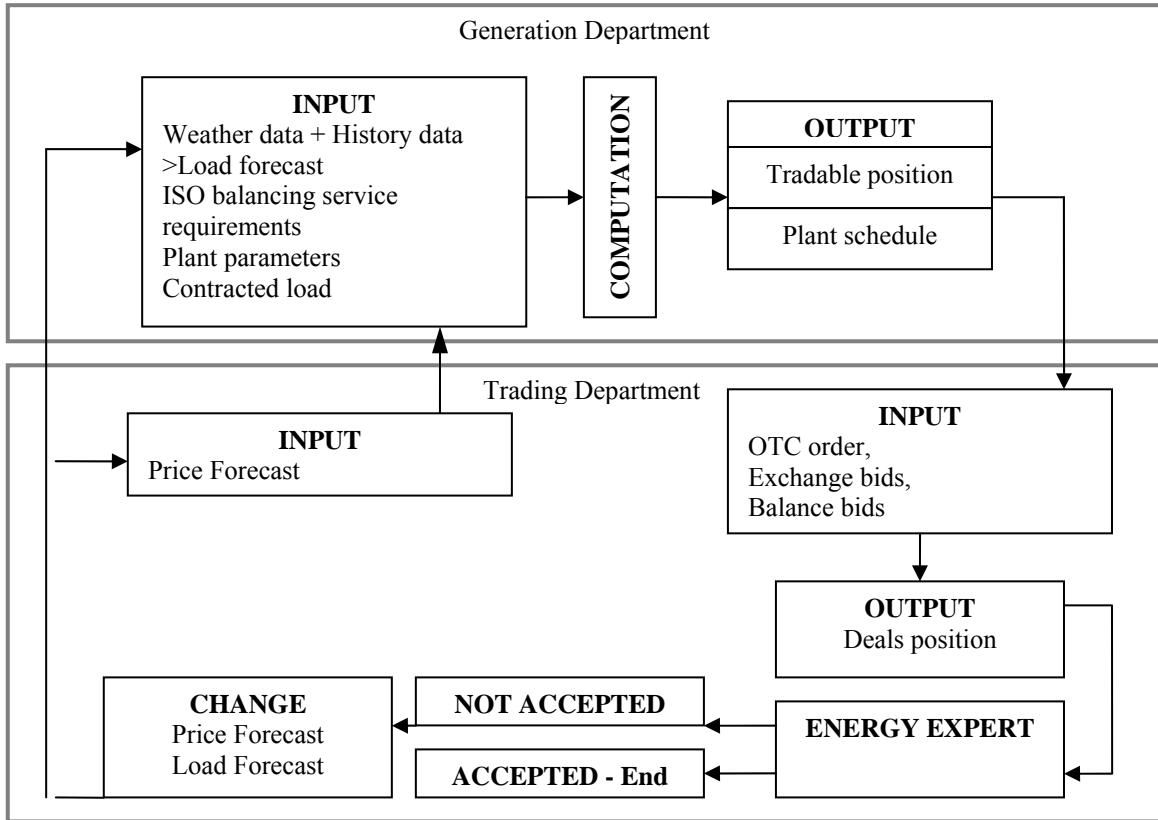

Figure 40. Production strategy preparation process in BoFiT (one day ahead); Explanation: ISO Independent System Operator; Duration of the computation stage is split into stages see Table 8 on page 88.

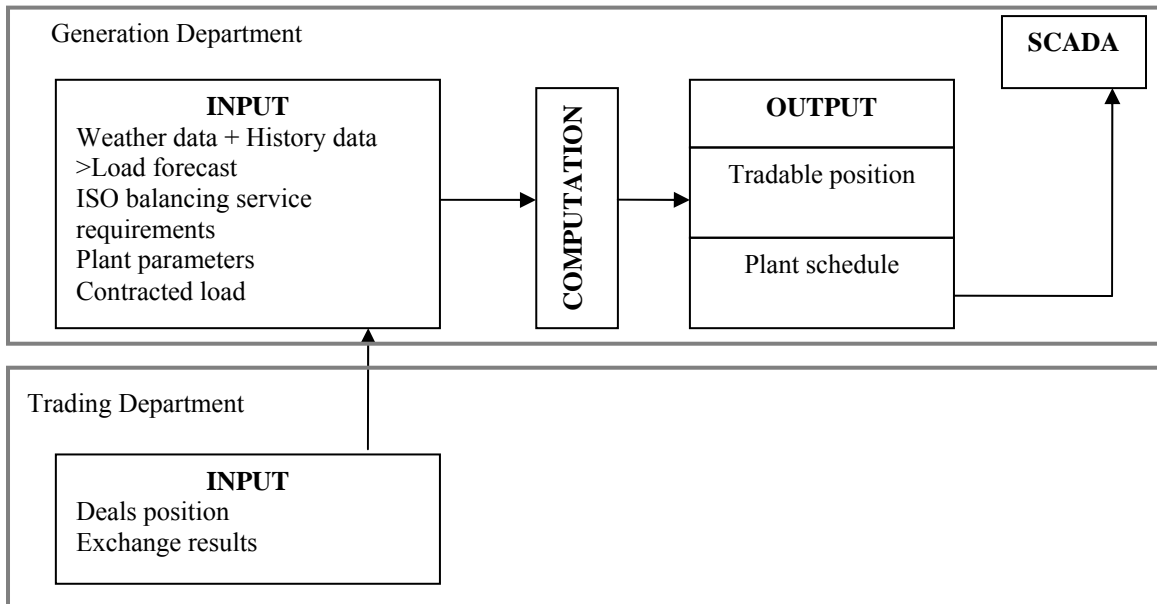

Figure 41. Production strategy preparation process in BoFiT (after the trading session); Explanation: SCADA Supervisory Control And Data Acquisition, ISO Independent System Operator

From the analysis of the PSt preparation process, the following limitations are gathered:

- Time of one repetition of the cycle includes the time for the decision of the human decision maker (DM).
- PSt preparation takes place approximately 3 hours before market closure (off-line planning).
- The maximum number of repetitions can be calculated as a time for offline PSt preparation divided by time for single PSt preparation cycle.
- Quality of the forecasts stays the same during the PSt preparation but the DM can learn from the results of computation and improve the input for the next production scenario.
- All data pass through the computation stage.
- Trading department needs only selected set of parameters from the result of model computation.
- Energy production technology department needs entire set of parameters from the result of model computation.
- The energy trading strategy is physically linked with the process of energy production. The reason is that electricity can not be efficiently stored.
- Electricity – large energy pool contracts are fixed and the balancing part is tradable at the day-ahead market.
- Heat – entire energy pool is contracted by fixed contracts (ability to trade heat on short-term depends on the heat supplier infrastructure ability and local policy).

The repeating cycles of PSt preparation is a solution for the need to meet at the same time the requirements of the energy generation and energy trading departments. (See also Chapter 2 point 5.2) The result of the computation is always feasible for the technology department, but it may not meet the objective of the trading department to maximize the profit. This is why the PSt preparation cycle is repeated in order to find the best configuration of energy production quota and trading contracts.

### The PSt preparation process analysis – contradictions

The PSt preparation process can be described by the means of contradictions presented below:

→← Contradiction: Data amount

We would like to have many data, in order to have feasible production scenario and we don't want to have many data, in order to reduce the time of the PSt preparation cycle.

→← Contradiction: Feasibility

We would like to have the feasible solution well fitted to the conditions, in order to have reliable effect, but we don't want the well fitted solution, in order to have a margin for adjustment of to the current situation conditions to the conditions on the delivery day.

→← Contradiction: Repetitions

We would like to make repetitions in the scenario analysis method, in order to evolve the strategy towards the best economic solution and we don't want to make repetitions, because it involves each time a time consuming computation.

→← Contradiction: Decision maker (DM)

We would like to use an algorithm instead of human DM, because it analyzes faster the situation and we don't want to use an algorithm because it lacks in experience and experience in ability to apply it.

## 1.2.5 Knowledge capitalization

The information about the system, obtained through the system exploration, need to be organized in order to do not loose them and to operate them efficiently during the further analysis. Defined problems and data required to describe them, are expanding the structures presented in the first knowledge capitalization in point 1.1.3. Below, there are presented fragments of the new content, which have been capitalized using the analysis tools: Multi Screen Scheme, CLD and Network of problems.

### Multi Screen Scheme of Inventive Thinking (System operator)

The production strategy (PSt) is a product of the process of energy production strategy preparation. In the conditions of the day-ahead market, the PSt is prepared one day before the delivery day. This mechanism is presented on the two following Multi Screen Schemes on (Figure 42). Figures a) and b) show the schematic organization of the thinking process built by the researcher for the purpose of organization of the knowledge about the issue of PSt preparation. The scheme in the part b) of (Figure 42) is a decomposition of the one screen in part a) – marked by dashed line.

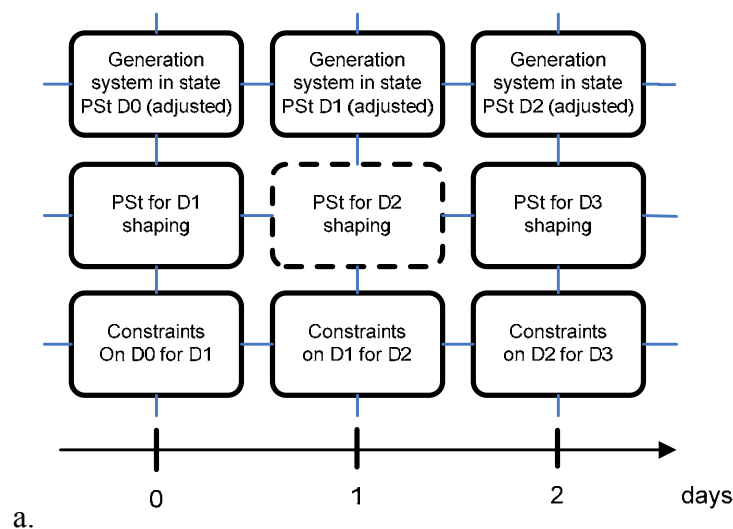

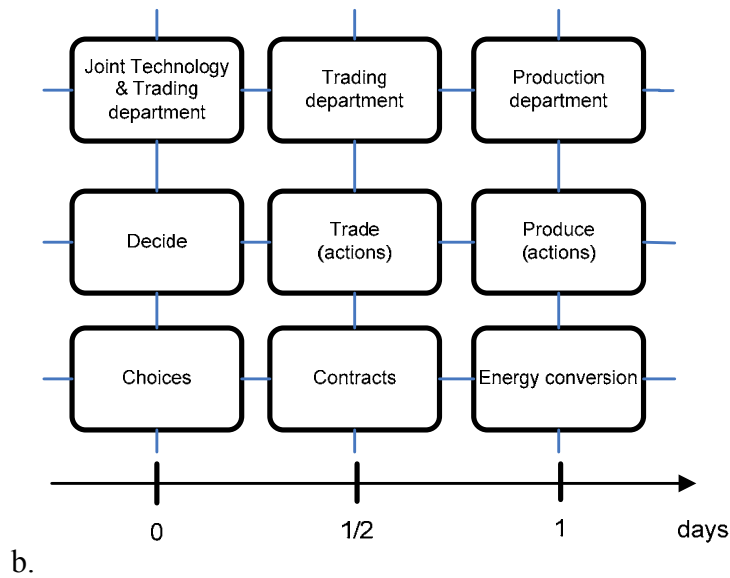

Figure 42. Multi Screen Scheme – Preparation of the PSt

### CLD

The problems formulated, during the continuing system exploration, are related to the quality of the PSt. For example: compare the contradictions in point 1.2.4 and also contradictions on Figure 37 and Figure 38. This information delivers many details. In order to understand them better it is proposed to draw the CLD basing on this knowledge. The visually simple CLD in fact contains many information thanks to the feed back loop concept and the polarization of the links. (Figure 43)

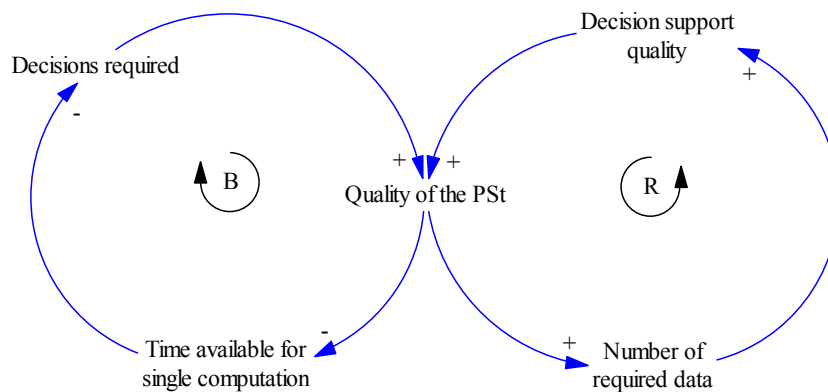

Figure 43. Causal Loop Diagram (CLD) – Quality of the PSt

### Network of problems

Network of problems has a structure based on the simple concept what facilitates its utilization during the analysis process. It can be used as a mean of communication with experts in order to settle the information about the partial solutions and problems encountered in the system. Fragment of the network of problems presented on the (Figure 44) cumulates problems related with the energy production issue from the point of view of technology. The creation of this region of the network was stimulated by the opportunities created by the physical connections between energy generation units in the GENCO i.e. via the electricity network and heat distribution network.

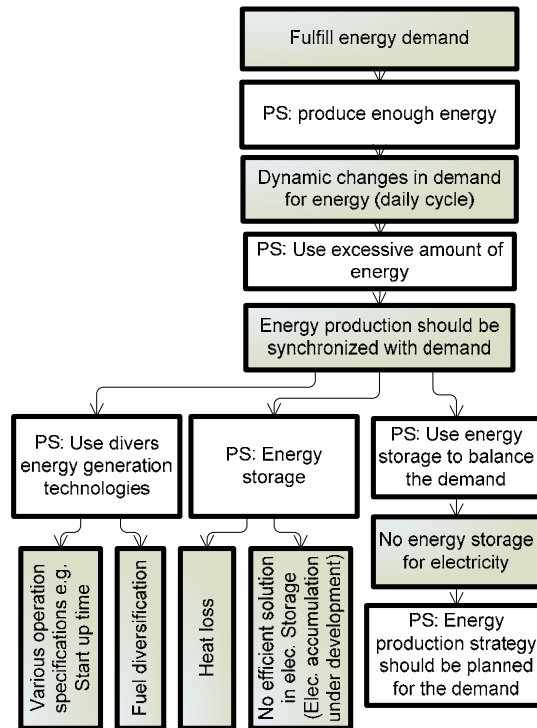

Figure 44. Network of problems – Energy production principle

Figure 44 - the base for the energy production strategy preparation is the energy production process. Thanks to the concept of the network of problems, and the technique of its construction, the energy production process is detached from the production sequence. In this case only the identified, recognized problems are put into the structure of the network. This gives a chance to link the problems and partial solutions from different regions of the system e.g. the problem in technology stimulated the partial solution (PS) in the production strategy ‘Use divers energy generation technologies’, but down the way this PS causes again a problem in the production process.

Complete network of problems constructed for the problem analyzed in the thesis is presented in Appendix 3.

## 1.2.6 Synthesis

Formulation of the problem using the model of contradiction gives the view on the problem in two ways with positive and negative values of the describing parameters. The exploration of the system going from problem to problem is supported by the analysis along the processes in the physical system e.g. energy generation technology, decision making process.

The knowledge capitalization in this part grows with the addition of new information about the system of problem obtained through the results from application of analysis tools. The process of the knowledge capitalization organizes the system of problem.

### 1.3. Laws of technical system evolution

The utilization of the one of the evolution laws is presented here in the application to the technical part of the physical system used in the thesis. The objective of the application of this technique is to integrate the information about the physical system. Among the laws of technical system evolution in the OTSM-TRIZ, the law of energy conductivity in system is chosen here to analyze the energy flows in the system. The technique of the 'energy conductivity' analysis includes the model (Figure 45) with the list of elements, which should be defined in the analyzed physical system. The obligation to define the elements listed in the model induces the collection of information about:

- the physical system
- elements of the physical system
- relations between elements
- how the elements are controlled
- what kind of flow can be identified in the system
- what is the level of controllability of these flows

The pieces of information collected to complete the model for analysis of the energy conductivity, are used in the description of problems and relations used e.g. in the construction of the network of problems.

#### Energy flow

This is a description of the heat and power cogeneration process using the law of energy conductivity. (Salamatov 1999 p.82) The description of energy conductivity in the energy production process is a very direct way of presentation but it is interesting to collect this information in one place and to define the particular functions i.e. tool, transmission, engine.

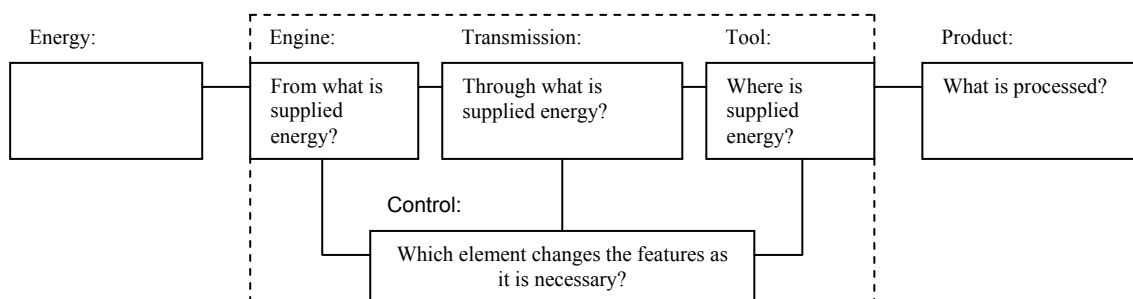

Figure 45. Energy flow in the system - model

#### Rules (Salamatov 1991)

It is advised to apply one sort of energy.

The type of energy put in order of increasing ideality:

Gravity → mechanical → thermal → magnetic → electric → electromagnetic

#### Questions:

These are questions which should be answered in order to describe the system and a problem located in the system: (Slide 68 in (Kucharavy 2003))

- Does energy pass through all components of system?
- Does energy pass through engine, transmission, tool and control?
- What is the best conducted field for the substances in the system?

- Is it possible to apply better controlled field?
- What is the best field for using in the new system (available or free)?

Table 9. Energy flow in the energy generation system

N°	Energy→	Engine→	Transmission→	Tool→	Product→
		From what is supplied energy?	Through what is supplied energy?	Where is supplied energy?	What is processed?
1.	Fuel combustion				
	Thermal	Natural resources (coal, gas etc.)	Conversion	Hot exhaust gas	Exergy – the utilizable part of energy
	Control: Furnace				
2.	Fuel combustion				
	Thermal	Furnace combustion	Gas oxidation	Heat exchanger	Heat energy (fluid-fluid)
	Control: Furnace with heat exchanger, fuel and air ratio, fluids circulation in the heat exchanger				
3.	Heat exchange				
	Thermal	Hot exhaust gas	Conduction	Fluid	Heat energy
	Control: Ratio of stream of exhaust gas and fluid				
4.	The mechanical force				
	Mechanical	Pressure	Expansion	Turbine	Mechanic energy
	Control: Pressure reduction stations, multi-stage turbine				
5.	Electricity generation				
	Mechanical	Turbine	Shaft	Generator	Electricity
	Control: Steam pressure, multi-stage turbine				
6.	Energy from CHP plant				
	Thermal/mechanical	CHP*	DH*/Electricity network	Heat/electricity powered devices	Work
	Control: multi-stage turbine				
7.	Energy carrier				
	Thermal	Heat	Change of the aggregation state	Fluid (Energy carrier)	Energy carrier (hot water, steam)
	Control: heat exchanger, boiler drum, condenser				

Explanation of used terms:

CHP – Cogeneration Heat and Power

DH – District Heating

#### 1.4. AIS

Analysis of initial situation (AIS) is a method including several techniques. The application of this set of techniques has following objectives:

- to research the initial situation where the problem is identified,
- to gather information about the system,



- to gather information about the alternative solutions,
- to battle the mental inertia.

The application of the AIS to the system of problem of the PSt preparation process can be followed in the Appendix 1. The appendix presents the utilization of three out of nine selected techniques: By-pass technique, Selection between the original and by-pass problem, Size Time Cost operator. The results from the application of the AIS are presented in Table 10 listing the applied technique and the short summary about the contribution to the system analysis.

Table 10. Techniques in the AIS with the notes about the contribution to the complex system analysis.

Name of the technique	Contribution to the complex system analysis
Determination of the final goal	This technique provides few different approaches to describe the objective of the problem solving. The description of the goal is supported by the characteristics or affordable expense. Thanks to this technique, instead of just setting the goal, it gets an extended documentation.
By-pass approach	In this technique, the alternative solutions to the problem are defined. This stimulates to describe the limitations of the research field i.e. why certain by-pass approach can not be applied, or it is possible to get the solution which is more robust.
Quantitative characteristics	The definition of the quantitative characteristics describes the initial situation and the constraints for the solution. This technique stimulates to express the descriptive characteristics, relations or limitations into the quantitative values.
Define the working conditions for the solution	The objective is to narrow the research area.
Use patent information	Search the existing solutions for the solutions of the similar problems. Description of the trends in solutions applied in the same domain.
Use STC operator (Size Time Cost)	Description of the problem and the potential solution from the different point of view. It provides the chance to redefine or complete the description of constraints, especially related to the different meaning of size, time and cost (STC).

## 1.5. ARIZ – step back

The step back analysis uses the already existing solution in order to learn about the problem solved by its application. The solution analyzed in the ‘step back’ analysis is chosen from the solutions which solve the problem similar to the problem in the physical system analyzed in our problem solving process. The similarity may refer to the main elements of the physical system, conditions of the particular situation etc. However the analyzed solution can not be directly applied to the problem analyzed by us.

The advantage of this technique is, that by the analysis of the complete solution, by the comparison with our physical system, it drives the attention to the elements, relations and processes, that may have been omitted in the previously performed analysis. In this way it supports the collection of information about the available resources for the problem solution. The other objective in the step back technique is to find the source problem resolved by this solution. This search for the root problem may have several steps and the real initial problem may be hidden. The most interesting finding in this analysis is when the root problem in the researched existing solution and our problem are common.

Features of the ‘Step back’ analysis:

- Exposes elements and relations in the system from another point of view,
- Guideline for the analysis of existing solution,
- Search for common problems or approaches,
- Search for the source problem.

The step back analysis is used as a guideline to research the existing solutions for common problems, approaches or regularities. This feature of the step back analysis is similar to the KJ method described in point 6.5. For example, DM is using several approaches to formulate the production scenario basing on the input data. These approaches are usually described in the form of methods recommended as a result of scientific research.

Each of these methods solves different particular problem. The expected result of the ‘step back’ analysis is the identification of problems common for the existing solutions and the researched system. Existing solutions already proposed some path to solve the common problem. Analyzing existing approaches it is possible to learn about the successful solutions and identify the way to upgrade them by the solution to the root problem.

The step back analysis is advised in the 4<sup>th</sup> step in the ARIZ algorithm (ARIZ is a Russian acronym for: Algorithm of Inventive Problem Solving).(Altshuller 1989)

First ‘Step back’ analysis uses the solutions proposed by the OSCOGEN research project (Optimization of Cogeneration Systems in a Competitive Market Environment). In (Paravan, Brand et al. 2002) the authors propose to split the decision support tool for the CHP into three parts:

1. Modeling CHP uncertainties
2. Optimal CHP production planning
3. Bidding tool for optimum electricity trading and decision making

The notes about this and other selected solutions can be found in the Table 11.

Table 11. Step back analysis – solution and the solved problem

Name and description of the solution	Solved problem	New problem which appeared
1. OSCOGEN		
Decision support tool split into 3 parts	Separate tools to address the 3 main issues, it is difficult to set up the bid without production planning.	The third stage has a time deadline to be completed and the stages 1 and 2 are time consuming.
Introduction of the market element into the model	Simulation of the energy market conditions in the model of the energy production system.	More opportunities and more uncertainties
Introduction of the identified uncertainties (Brand, Thorin et al. 2001) into the optimization model	Controlled simulation of the liberalized energy market.	Necessity to use stochastic optimization
Scenario is constructed using the decision tree (Brand, Thorin et al. 2001; Brand and Weber 2002)	Need to analyze all scenarios. Scenario analysis and heuristics do not consider all scenarios.	Time consumption by computation rises.
Scenario reduction technique	Too many scenarios to optimize.	Not all scenarios are considered.

Name and description of the solution	Solved problem	New problem which appeared
2. Decomposition technique (Makkonen and Lahdelma 2006)		
<ul style="list-style-type: none"> <li>○ decision problem formulated as a large mixed integer programming (MIP) problem</li> <li>○ to make the model manageable it is composed hierarchically out of modular components</li> <li>○ model is decomposed into hourly sub-problems</li> <li>○ customized Branch-and-Bound algorithm to solve sub-problems</li> <li>○ generic method for encoding of non-convex power plants in the model</li> <li>○ non-convex energy optimization method is an extension to the EHTO which is an element of GENERIS</li> </ul>	<ul style="list-style-type: none"> <li>○ Need for the more versatile (to easier maintain the model and keep the model parameters up-to-date) and efficient decision-support tools for energy companies.</li> <li>○ Energy traders need tools for quantifying the risks and determining the use of different risk hedging instruments.</li> </ul> <p>Need for Rapid re-optimization:</p> <ul style="list-style-type: none"> <li>○ when situation on the market changes</li> <li>○ advanced computations, such as risk analysis through stochastic simulation, requires the solving of a large number of models rapidly</li> </ul>	High time consumption of optimization of large problems. The reason is the exponential relation of time and number of plants, areas defined in the model.
3. Real options - German energy market (Hlouskova, Kossmeier et al. 2005)		
<ul style="list-style-type: none"> <li>○ Real options model for unit commitment problem of a electricity producing turbine in a liberalized market.</li> <li>○ the unit commitment can be solved independently from the entire portfolio (under condition that the market is enough liquid)</li> <li>○ capture of the price uncertainty in the model</li> </ul>	<ul style="list-style-type: none"> <li>○ Deregulation: physical problems (electricity shortage) + price fluctuations (financial risk)</li> <li>○ profit maximization under uncertain prices</li> <li>○ optimal operation of the power plant</li> <li>○ profit and loss distribution</li> </ul>	<ul style="list-style-type: none"> <li>○ The model is complicated,</li> <li>○ Utilization of this model is advised for the 'peaking units'.</li> </ul>
4. Deregulated energy market in California (Yan and Stern 2002)		
It is a business solution. The change in the objective gives a better performance of the market as a whole, there is a save of money, the energy is traded cheaper, the units are optimizing themselves on the different objective in the Simultaneous Optimal Auction.	New situation in the energy generation system – introduction of the ISO (Independent system operator) and the PX (Power exchange).	It is a business solution in the rules for the energy market. It points the attention to the constraints of the market conditions.
5. Case study of the CHP plant in Greifswald (Jost 2001)		
<ul style="list-style-type: none"> <li>○ Combination of production and trading the energy in the CHP plant.</li> <li>○ Optimization of the electricity production component in the co-production cycle.</li> </ul>	<ul style="list-style-type: none"> <li>○ harmonization with the available external resources</li> <li>○ contradiction solved – we want to produce energy in our plant in order to economize it and we don't want to produce energy in our plant in order to have cheaper energy bought outside.</li> </ul>	<ul style="list-style-type: none"> <li>○ The solution is prepared for the scheme of single CHP working with the electricity grid and the local DH system.</li> <li>○ The urban energy production system usually consist several production units.</li> </ul>

## 1.6. Bottleneck

The analysis of the bottleneck is a technique looking for the next problem which will appear in the system where the current problem resides. The solution to the problem under research will disclose the new problem, which stays on the way to the ideal solution. This problem may become soon the initial problem. The current problem and the future problem block the development of the system towards the ultimate goal. They act as a bottleneck slowing down the flow of a liquid. In between these problems there may be more of partial problems but the most relevant of them are called bottlenecks. Solving a particular problem, the information and data about the physical system and system of problem, they are already collected. There is a need to take a different point of view and look forward in the process of system development after the current problem is solved. In order to look for the next bottleneck, let us assume that the current problem is solved. What is the next problem? This way of the analysis can be continued further after the first bottleneck is found. The desired result of this analysis is that the solution to the next problem overcomes current problem under the described particular situation conditions. The solution to the next problem may have better conditions, access to resources etc. and be more robust by solving other related problems.

In the analysis of the PSt preparation system, the addressed initial problem is the high time consumption of the computation process. The analysis of the problem and the system revealed the root problems i.e.: number of data, number of constraints, mixed integer formulation of the problem. These problems are linked with the technology limitations of the energy production plant and rules of the energy market, which describe the constraints of the problem situation conditions. In order to skip the present bottleneck it is assumed that the problem of the time consumption is solved. The computation process is performed after 1% of the current time consumption e.g. in 1,8s instead of 180s. Thanks to the solution, the process of PSt preparation increases the number of computations. It is possible to perform more computations in the same time frame as before. The next bottleneck which emerges is the human decision maker (DM).

The duty of the DM is to analyze the initial data, the results form the computation in order to form the production scenario for the next computation. (Figure 46) The production scenario is a concept proposition of setup of the urban energy production system for the day-ahead delivery. The production scenario consist of several variants e.g. 10 variants. The variants are generated automatically according to the main idea formulated in the production scenario e.g. even spread of values in the predefined range. Since the time consumption of the production scenario computation is reduced the frequency of decisions which DM has to made augments e.g. 100 times faster computation, even if we order 10 times more variants for each scenario (10 variants before, now 100), DM has still a time to prepare 10 times more production scenarios, this means a need to make 10 decisions instead of one before. In the previously used example where computation of single variant takes 180s before the solution, it gives one decision every 3 minutes comparing with one decision every 30 minutes before the solution. Intensifying this relation, the human DM is unable to make more decisions. The human DM is a bottleneck in the process of development of the PSt preparation process.

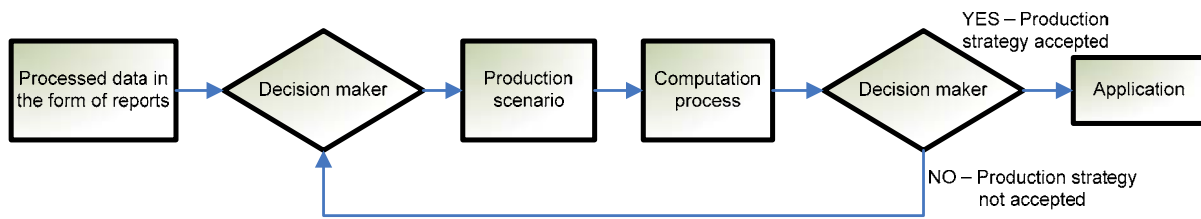

Figure 46. Decision maker (DM) and computation process

How real is that the next bottleneck will become the current problem? The fact is that the problem of the high time consumption is addressed in the two other ways outside the scope of the research presented in the thesis. These two approaches are, the development of the optimization algorithms and the progress in the computing hardware. Analyzing the progress in the optimization algorithms for the mixed integer problems and the progress in computation speed of computing servers in the period of last 20 years, the desired reduction of the computation time to the level of 1% of current value will be possible in approximately 10-12 years (from 2006). (Bixby, Fenelon et al. 2000; Bixby 2002; Bixby, Fenelon et al. 2004; Dongarra 2006) It is reasonable to consider the application of the human DM, already, as a current problem.

→← Contradiction:

We would like to make many cycles of optimization in order to approach an ideal solution and we do not want to make many optimizations because the human DM is unable to make faster decisions.

What is a problem with the DM?

- All necessary data to form the best production strategy are available in the existing solution, but it is impossible to form it because DM has not a complete comprehension of a system's characteristic.
- Any trial to comprehend the model is going towards the complete computation of the model using the method of trial and error.

The focus on the problem is shifting from the initial problem declared by the ProCom company to the problem of decision making and utilization of human DM.

DM position in the nets

The role of the DM in the process of production strategy preparation dominates the late stages of the analysis. Reading the network of problems or the IDEFØ is the best way to learn about the DM's localization in the system of problem of production strategy preparation. These schemes present the result from the complex system analysis performed by the means of the analysis tools and foundation on the continuously developed database of knowledge.

## 1.7. Additional features of the system observed during the analysis

Analysis of the system, performed with the basic analysis tools, revealed information about the system, problems and relations in the system of problem. Out of these information, their amount and their multidisciplinary character, it is possible to recognize two features characterizing the system of problem. These are: synergy effect and dynamicity. These two characteristics increase the complexity of the system.

Synergy is an effect appearing in the system when the change in one element of the system causes the change in the other element. These changes take place by the means of relations which may not be always recognized or intended. In the system of PSt preparation the synergy is manifested for example in the relation between technology system of energy generation and the planning in the trading department. For instance, the minimal change in the amount of energy planned by trading department for the production, can significantly change the configuration of the production units required to realize this plan. The direct cause is the marginal price going up due to the start up of the new energy generation unit if some threshold is passed.

The dynamic characteristic of the system, turns the synergy into even more significant problem, especially when we would like to understand the characteristic of the system. Dynamic changes in the system make the all parameters in the system changing in the real time. Each change in one element influences the nearest system and by the means of synergy it changes the entire system. The source of the dynamic changes in the system of urban energy generation, are the variations in the energy demand: in the form of electricity following the changes in the daily activities and heat consumption depending on the weather conditions and daily activities as well. The consequence of the dynamic behavior of the system is that there is no stable configuration of the system, each time the state of the entire system is different. Through the analysis of the historical record of system configurations, it is possible to recognize the similarities and apply them to support the present decisions. However due to the complexity caused by the dynamic characteristic of the system and the number of parameters, the identical configurations are not used and not searched for in the database.

→← Contradiction

We would like to have a synergy in our system because with small changes we can obtain greater results and accurately manage the system, but we don't want to have synergy because it causes effects under complex unknown rules. (Figure 47)

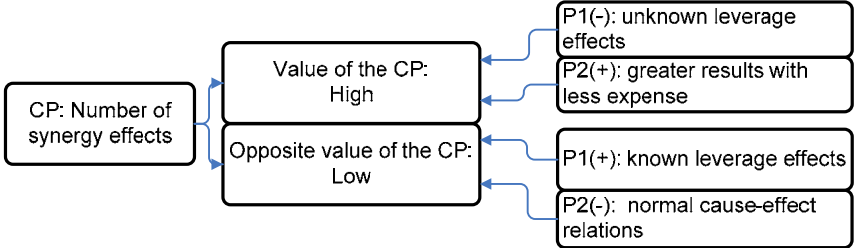

Figure 47. Contradiction: Synergy effects

Dynamic feature of the system – synchronization with the environment

Because of the human activity and activity of natural systems e.g. energy circulation, water circulation, the maintenance of the balance of energy in the nature causes dynamic changes. Natural systems are working with huge amounts of energy e.g. solar activity, wind, water circulation. The artificial, anthropologic systems deliver energy in various forms according to the human's demand.

There is a group of artificial systems, which are directly dependant on changes in nature systems e.g. delivery of heat when temperature goes down, delivery of light when it's getting

dark, etc. These systems follow the environment in order to maintain equal conditions. These systems are not efficient due to the lag in reaction to dynamic changes e.g. reaction to the surge in demand for electricity or heat. The solution used in the energy generation systems is to maintain the production on the level higher than the variations in demand. The energy production utilities work more efficiently when they work constantly and at their designed performance level.

Coexistence of environment and artificial systems should be dynamic in order to maintain the balance in the super-system of environment and should not be dynamic in order to let the artificial systems work more efficiently.

→← Contradiction

In the coexistence of environment and technology systems, the technology system should be dynamic in order to maintain the balance with the super-system of environment and should not be dynamic in order to enable technology systems to follow the changes.

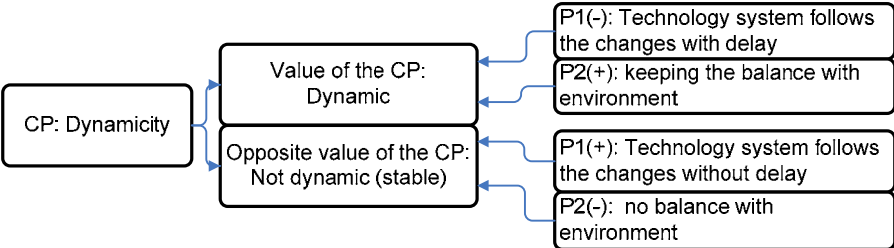

Figure 48. Contradiction: Dynamicity

1.8. Synthesis

The analysis tools presented in this part were used for the exploration of the system of problem. These tools can be, if necessary, applied in the iterative way in order to explore different regions of the system or in order to deepen the knowledge about the particular part of the system. The tools like AIS, 'Step back' technique or 'Bottleneck' technique were used in order to diversify the point of view on the system of problem and to deal with the mental inertia during the analysis. The data obtained from the analysis tools are organized by the means of analysis tools for information management e.g. Multi Screen Scheme, IDEF0 scheme, Network of problems.

This part of Chapter 4 presented the systematic construction of the knowledge, first by the exploration of initial problem, second by the guided exploration of the system of problem. The pieces of information are numerous and they need to be operated for the further development and search for the key problems. The base for the information management tools is already made. In the next part of Chapter 4 the results of the first part will be developed and operated in order to control the system of problem. Construction of the network of contradictions, presented in the following point, is built by transformation of the network of problem, whose construction has been already started in the guided problem exploration.

## 2. Organization of problems, partial solutions, relations

The picture of the analyzed system e.g. in the IDEFØ or network of problems, is a map presenting the results of the analysis, but it also keeps the underneath links to the analysis tools applied during the analysis. Then through the analysis tools the links go to the knowledge base used in the analysis tools.

### 2.1. Multi Screen of the research

The Multi Screen Scheme of Inventive Thinking (System operator) is used first of all to organize and guide the thinking process. The scheme is build during the analysis in order to support the thinking about the current issue. The structure of the system operator helps to put the knowledge about the different parts of the system in place. Before and after systems store the relative information about the changes in the chosen time span. Thanks to the concept proposed by the Multi Screen it is easy to move through the analyzed system taking care to describe the obligatory elements of the Multi Screen. The construction of the system operator is described in Chapter 4 point 1.1.3 page 90. The obligation to operate the system operator forces the user to apply the particular scheme of thinking, which guides the exploration of the analyzed system i.e. it is required to describe the sub-system, describe the after system of the sub-system etc. Each screen in the system operator can be decomposed, it means that each screen displays the system which can be presented as a multi screen scheme in the separate graph. The decomposition was used in the construction of the multi screen scheme for the system analyzed in the thesis – see Figure 42.

The Multi Screen Scheme (System operator) is built by the user as an individual tool for guided thinking and it is not recommended for the purpose of presentation. It is the most efficient in the guidance of the analysis e.g. describing the element of a system, system operator stimulates thinking in the scheme which requires the description of subsystem, super-system in vertical organization and the before, after system, referring to considered element in the horizontal organization of a scheme. For the presentation of the knowledge obtained through analysis process guided by Multi Screen, it is preferable to use IDEFØ diagrams, network of problems or developed CLD.

### 2.2. Problem dynamics with System Dynamics

The System Dynamics methodology for the analysis of the problem appearing in the complex system, uses two main concepts:

- The causal loop diagram (CLD)
- The stock and flow diagram, a concept used for the modeling.

For the introduction about the CLD construction, please see the point 1.1.3 in this chapter, the CLD section.

The CLD gives the dynamic view of the system elements. The polarization of links between variables engages the reader to follow the mechanism, which appear in the graph. The construction of the CLD diagrams can be supported by the 11 defined archetypes of



CLD. (Senge 1990) The construction of the CLD supports the data collection, especially in cooperation with experts. In the research presented in the thesis, the CLD were used to summarize the results obtained from other analysis tools. The compact form of the CLD is very efficient way to represent results and systematize the explored knowledge.

In order to construct the CLD two methods were used. One is a construction starting from the one loop and then developed by adding more loops. In this way, at some stage of construction, the diagram can match the defined archetype of CLD. This facilitates the recognition of the roles of particular elements in the loops. If the diagram does not match the archetype the analysis of the diagram is made by our interpretation. The second approach to construct the CLD is to analyze the defined archetypes and look for one which matches the system or the part of the system that we would like to describe. Then the variables in the archetype are replaced with the variables from analyzed system.

In order to capture the problem of human element in the system of energy production strategy preparation, it is proposed to present it by the means of CLD. The first CLD presents the DM as a solution in the decision making process. With a time when the demand for the decision making rises due to the complexity of the operated system, the DM becomes overloaded with decisions. The pressure on the DM comes from two directions, rising complexity of the system makes the decisions more sensitive and the profit maximization objective stimulates to more detailed analysis of the production scenarios. (Figure 49)

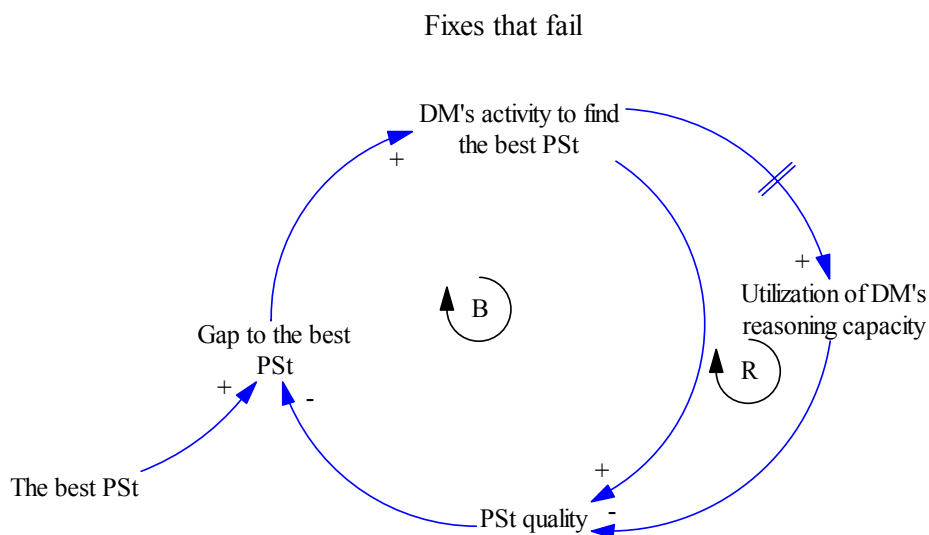

Figure 49. Causal Loop Diagram – Decision Maker, Archetype: Fixes that fail

The solution to the problem of DM is addressed in the following diagram. (Figure 50) This loop is based on the archetype 'Shifting the Burden'. It shows how the symptomatic solution of 'computation power' migrates to the need for fundamental solution of 'method development'. It takes time to recognize the need for the fundamental solution what is marked on the scheme by two lines on the arrow line, marking the delay. In order to make the reference to the DM, the variable 'computation power' can be changed into 'DM's reasoning capacity' which is a part of the decision making 'engine'. The CLD shows the important migration of the objective, which was initiated by the bottleneck analysis. The development of the system for energy production strategy preparation, from the focus on computing power and DM's ability, migrates to the development of the method for decision making. In this diagram the development of the method overcomes the drawbacks of computation power and human DM. (Figure 50)

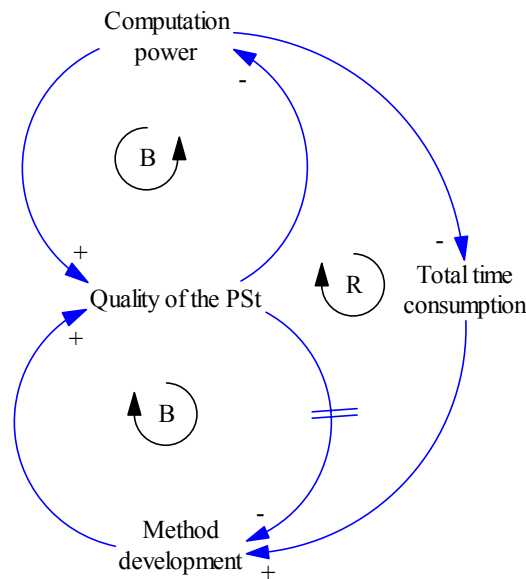

Figure 50. Causal Loop Diagram – Method Development, Archetype: Shifting the burden

### 2.3. IDEFØ of the analysis process

The IDEFØ scheme comparing with the Multi Screen Scheme, has more rules in its construction technique. In consequence it is less flexible during construction than the Multi Screen, but it is easier to read by an independent reader. Therefore it can be used in the communication with experts to present results but also to obtain and add further data to the graph. It can be also used for the internal communication of results for the researcher to get the picture of the obtained results. The IDEFØ scheme presents the functions and the relations between functions.

The brief guide how to construct and how to read the IDEFØ were introduced in point 1.1.3, Figure 26.

In the thesis, the IDEFØ diagram has been used in two ways, one to present the results of the analysis of the system of problem of preparation of energy production strategy. Second time the IDEFØ was used to analyze the construction of the method of analysis of the system of problem developed in the thesis. The first graph, IDEFØ of the production strategy preparation, presents the set of functions linked according to the results from the analysis. (Figure 51)

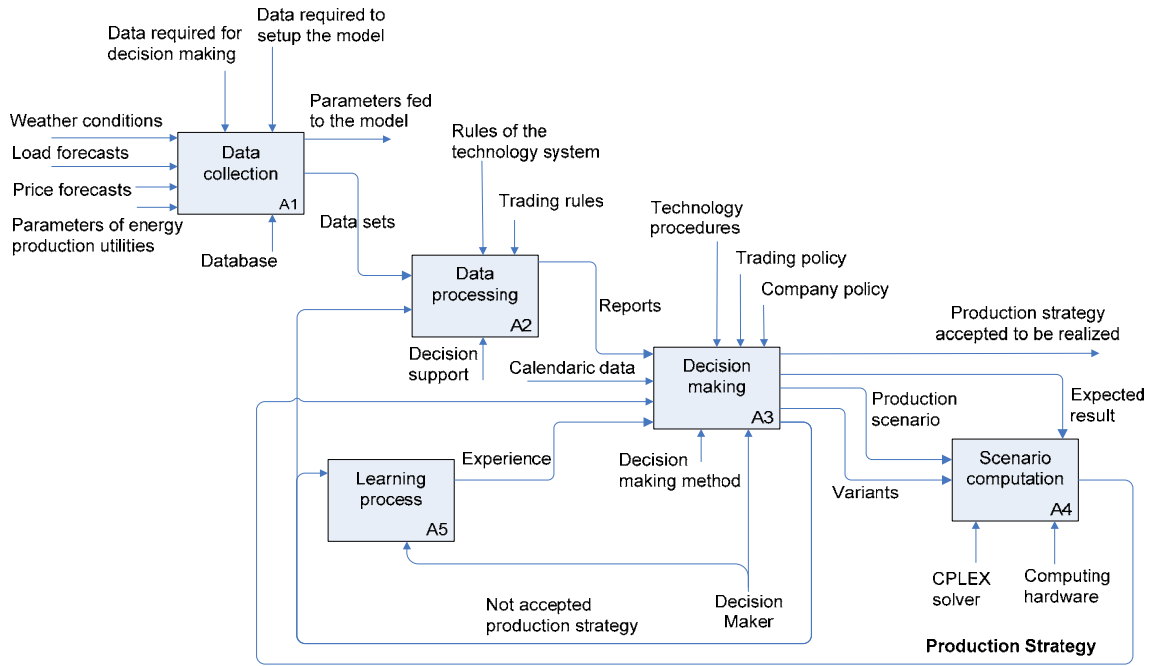

Figure 51. IDEF0 scheme of the production strategy preparation process

The second application of the IDEF0 contains information about the construction of the method of analysis during PhD research. Figure 52 presents the functions performed during the research including e.g. the description of the physical problem of production strategy preparation. The scheme on Figure 53 presents the description of the problem in the physical system – an approach used in the analysis of the complex system.

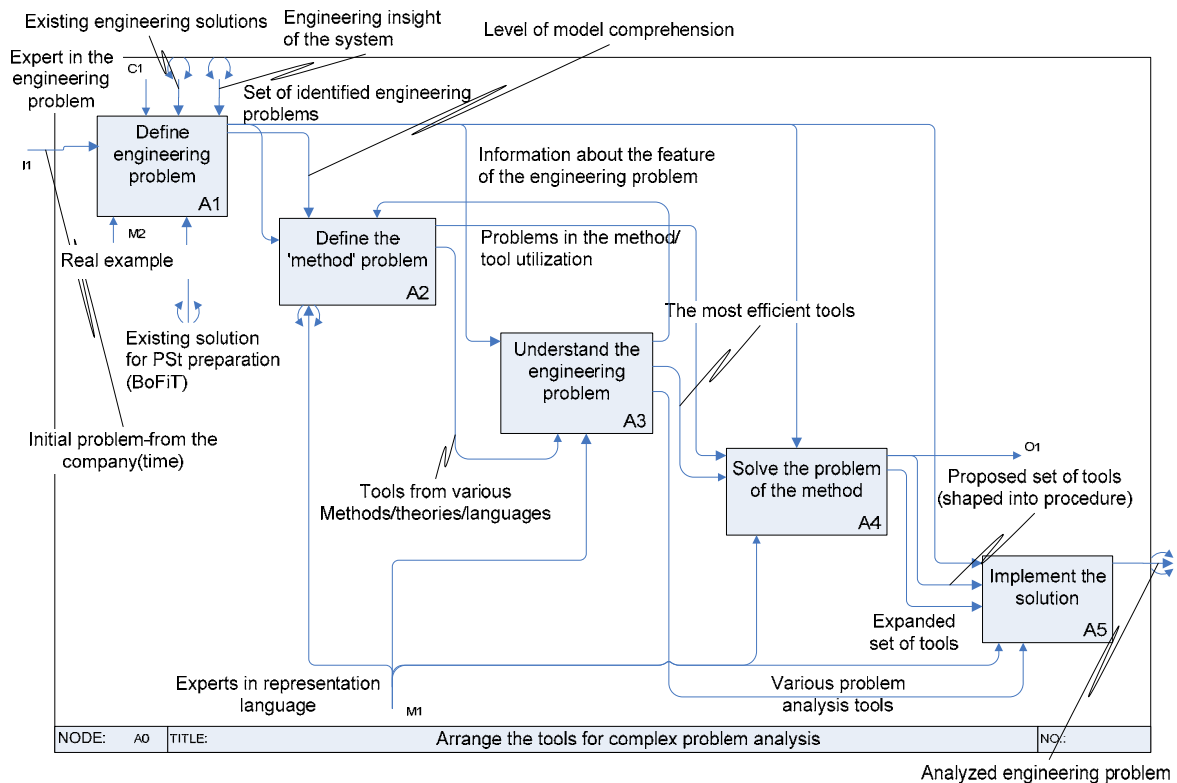

Figure 52. IDEF0 of the research – main structure, system analysis path of research

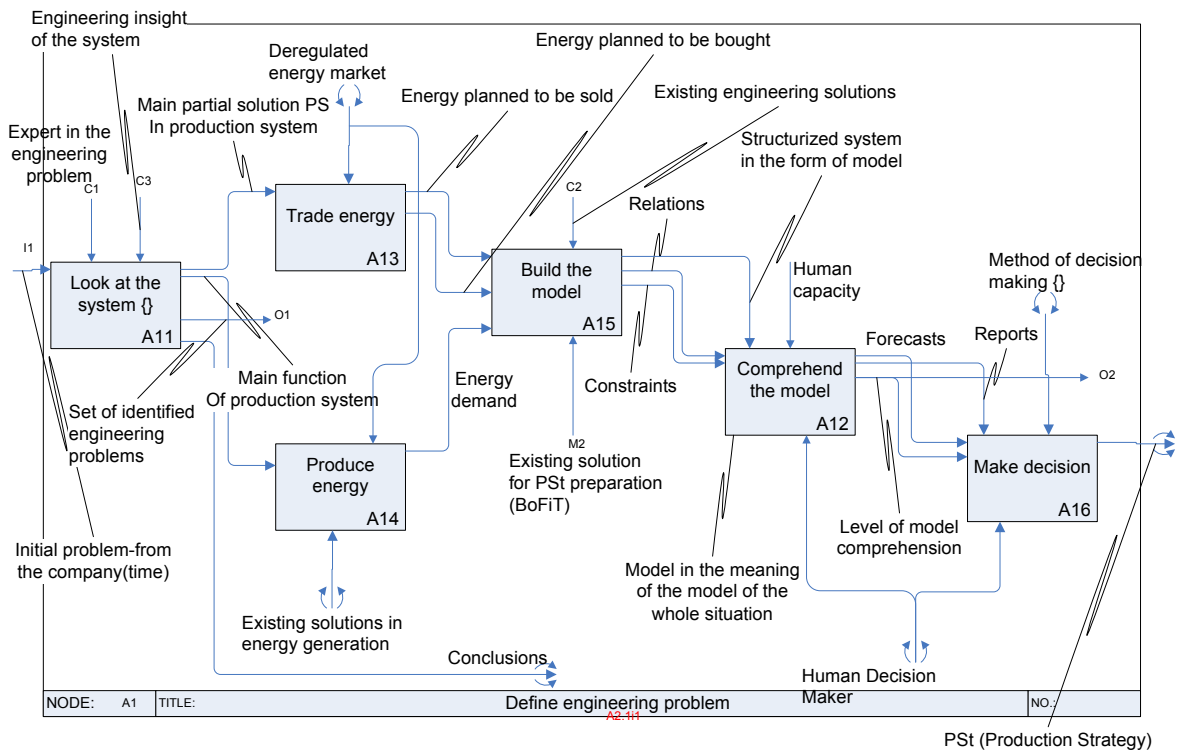

Figure 53. IDEF0 of the research – defining the problem in the physical system

## 2.4. Network of problems, Network of contradictions,

The network of problems is a concept from the OTSM-TRIZ. One of the objectives is to present the relations between problems, which has been identified as a result of application of several analysis tools. The technique of construction of the network stimulates the description of new problems which become exposed to the researcher when e.g. it is necessary to put the problems caused by the applied partial solution. It is particularly useful in gathering the information and in discussion with experts. Comparing to the IDEF0 diagram, network of problems requires fewer questions to ask in order to settle the element of the diagram. The construction technique is based on syntax including three elements: problem, partial solution and linking arrow. The problem element is associated with a goal, which is a part of the problem. The partial solution is applied to the problem and because it is only partial, it causes the further problems to appear. Complete network of problems constructed for the problem analyzed in the thesis is presented in Appendix 3.

Features:

- Lists problems and partial solutions.
- Presents links between problems and relations.
- It has simple rules of construction.
- Can be used in the work with experts in order to collect and visualize the information about the system.
- It is possible to tell which set of problems will be solved if the solution is provided to the particular problem in the network.

Network of problems is a preparation stage for the construction of the network of contradictions. The transition to the network of contradictions is a way to focus the attention on the key problems and express them in the form of contradictions. The network of contradictions is substantially smaller than the network of problems which often expands into different domains. Network of contradictions groups the contradictions, expressing the features critical to the objective associated with the key problem identified in the network of problems. The utilization of the network of contradictions leads on one hand to the solution for key contradictions and on the other hand to the comprehension of the analyzed complex system of problem.

I would like to propose the explanation of the effect of the system comprehension as a leverage created by the contradictions in the network of contradictions. This leverage reaches the elements of the physical system passing through the all stages of analysis. Going from the bottom, at the beginning there were exploration tools, then guidance tools, knowledge capitalization tools with network of problems and eventually the network of contradictions. Utilization of the model of contradiction as a final grip on the system has an extra advantage because, thanks to its construction, it operates in two directions listing the positive and negative parameters.

#### Construction of the network of contradictions

The process of the transition from the network of problems to the network of contradictions is not yet well described in literature. The method proposed in the thesis is based on the works by Khomenko et al. (Khomenko, Schenk et al. 2006; Khomenko, De Guio et al. 2007) and the consultations with expert in OTSM-TRIZ. For the more recent works on network of contradictions see (Cavallucci, Khomenko et al. 2005) and the latest paper on the construction of the network of contradictions (Khomenko and De Guio 2007). The following paragraphs describe the way how to construct the network of contradictions from the network of problems. The method is described basing on the set of rules and hypothesis used in the method proposed in the thesis.

### 2.4.1 Selection of the key problems

Resources – the transition starts from the network of problems. Fragment is presented on (Figure 54), complete scheme of the network of problem is presented in Appendix 3.

#### Counting the links

R1. Count the links coming into the box representing the problem. The links may come from the partial solutions (PS) or from the problems, in case that the intermediate stage of the PS was skipped.

#### Hypothesis

The high number of links to the box of a particular problem, indicates that this problem was more frequently pointed as a reason to not satisfactory partial solutions. The solution to this problem turns the partial solutions into satisfactory solutions, they do not generate problems. (This is in case if the PS was linked only to this problem.)

If the problem is linked by incoming links with higher than described average number of incoming links in other boxes, the solution to this problem will satisfy more needs. This problem recognized is a key problem.

#### Assessing the importance of the links

R2. Verify the following features of the links:

- Is it a link to a box, which was defined in the main part of the network or it is a link to the box in the additional description? Links between the boxes in the main part of the network are more relevant than the links to the boxes outside the central part.

#### Hypothesis

The links incoming to the box of problem have different importance. The links coming in from the boxes positioned in the main diagram are more important than links coming in from the boxes in the additional description areas. For instance, considered network of problems was built in several stages, starting from the central part, then it was expanded by the regions supplying additional information. Additional regions are linked with the main part but it is probable that these links are weak comparing with the links in the main part where the highly perceived problems are localized.

#### The threshold on the number of links

R3. Set the threshold on the number of links.

- Distinguish the number of important links among the links to each box.
- Set the number of links which qualifies the problem as a key one.

#### Hypothesis

There is number of links which describes the group of key problems among all problems in the network. Thanks to the number of links the group of key problems can be selected.

### 2.4.2 Change of key problems into the contradictions

R4. Define the objective

- Select first key problem.
- Indicate the number of connections incoming and outgoing.
- Make a citation of the problem expression.
- Describe in one sentence the need expressed in this problem.
- What is the objective denied by this problem?

The problem is caused by the fact that it is not possible to realize the certain objective.

R5. Describe features critical to the objective.

- What is critical to fulfill this objective?

- What features are critical to reach the objective?
- In order to identify the critical features – use the network of problems, observe the problems, PS linked to the considered box.
- List critical features.
- Extract the Control Parameters (CP) corresponding to the critical features. (the number of CP may differ from the number of critical features)

#### Hypothesis

The features critical to the realization of the objective are present in the network of problems. They can be recognized directly from the boxes in the network or by the creation of the link to the resources in the system analysis.

- R6. Use the scheme of the network of contradictions from the publication paper (Khomenko, De Guio et al. 2007) (Figure 55)
- Set the main element corresponding to the objective from the particular key problem.
  - Link the CP with the Main element
  - Form the contradictions from each CP using the information from the system analysis.
  - Name the evaluation parameters (EP) (model of the contradiction presented in the (Khomenko, De Guio et al. 2007) includes EP)

### 2.4.3 Selection of the key contradiction

The key contradiction in the network of contradictions describes the problem whose solution will bring the most benefit to the system of problem. Selection of the key contradictions is necessary to recognize the relations in the network of contradictions. Solution of the key contradiction should cause other contradictions to disappear. By selecting the key contradictions we will see which contradictions will not exist after the solution to the key contradiction. The problem with selection of key contradictions is to recognize the relations between contradictions in the net. We want to know all possible relations between contradictions in order to see all the consequences of the solution to the particular contradiction and at the same time we do not want to know all the relations because they are numerous for each contradiction and make the analysis time consuming. In order to deal with this problem it is recommended to use the network of contradictions in connection with the network of problems with supplementary descriptions from their construction process. This joint utilization of tools helps to find key contradictions.

- R7. Observe the contradictions during the construction process of the network of contradictions.
- Observe the position of the critical feature in the network of problems: connection to other key problems, how many experts defined this element, how early was the element defined, what analysis results support this element.

#### Hypothesis

The importance of the contradiction rises when it is constructed basing on the CP, a critical feature, the most relevant to the objective.

Selection of the key contradictions in the complete network of contradictions:

- R8. Consider the group of contradictions in the net linked under the one objective.
- R9. As the resource use the data collected in the analysis process.
  - o Use the described processes to find information about the relations.
  - o Observe the CP in the network of contradictions and problems in the network of problems in order to look for the relevant information in the resources gathered during the analysis i.e. results of analysis and data collected to conduct the analysis.
- R10. Abstract the data from the analysis resources. Detach the data from their place in the engineering system, in the process. In order to do this use the IDEFØ. e.g.
- R11. Recall the utilization of the Multi Screen Scheme of thinking during the analysis process. Use the Multi Screen Scheme to locate the CP.

Hypothesis

Passing the path to localize the CP in the Multi Screen Scheme helps to sort the relevant information from R9 and R10 in order to attribute the significance to the particular contradiction among other contradictions under the same objective.

2.4.4 Quick check of the key contradiction selection

Hypothesis: The particular contradiction is the key contradiction if the supposed solution of this contradiction causes other contradictions to be resolved for these particular conditions.

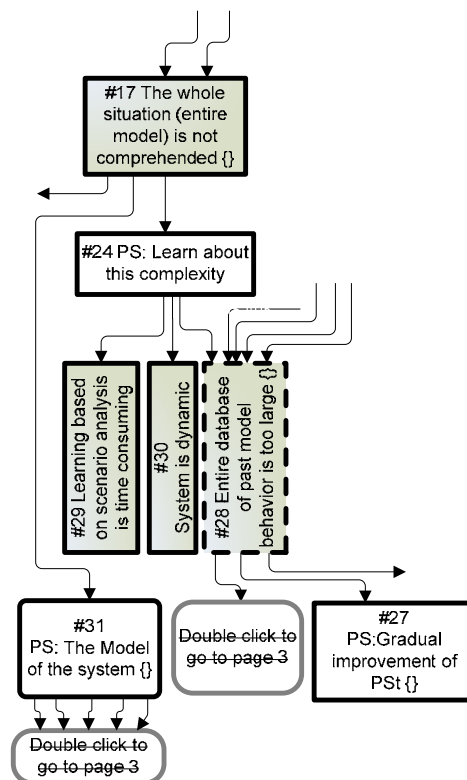

Figure 54. Network of problems – Key problem (marked by dashed frame line)



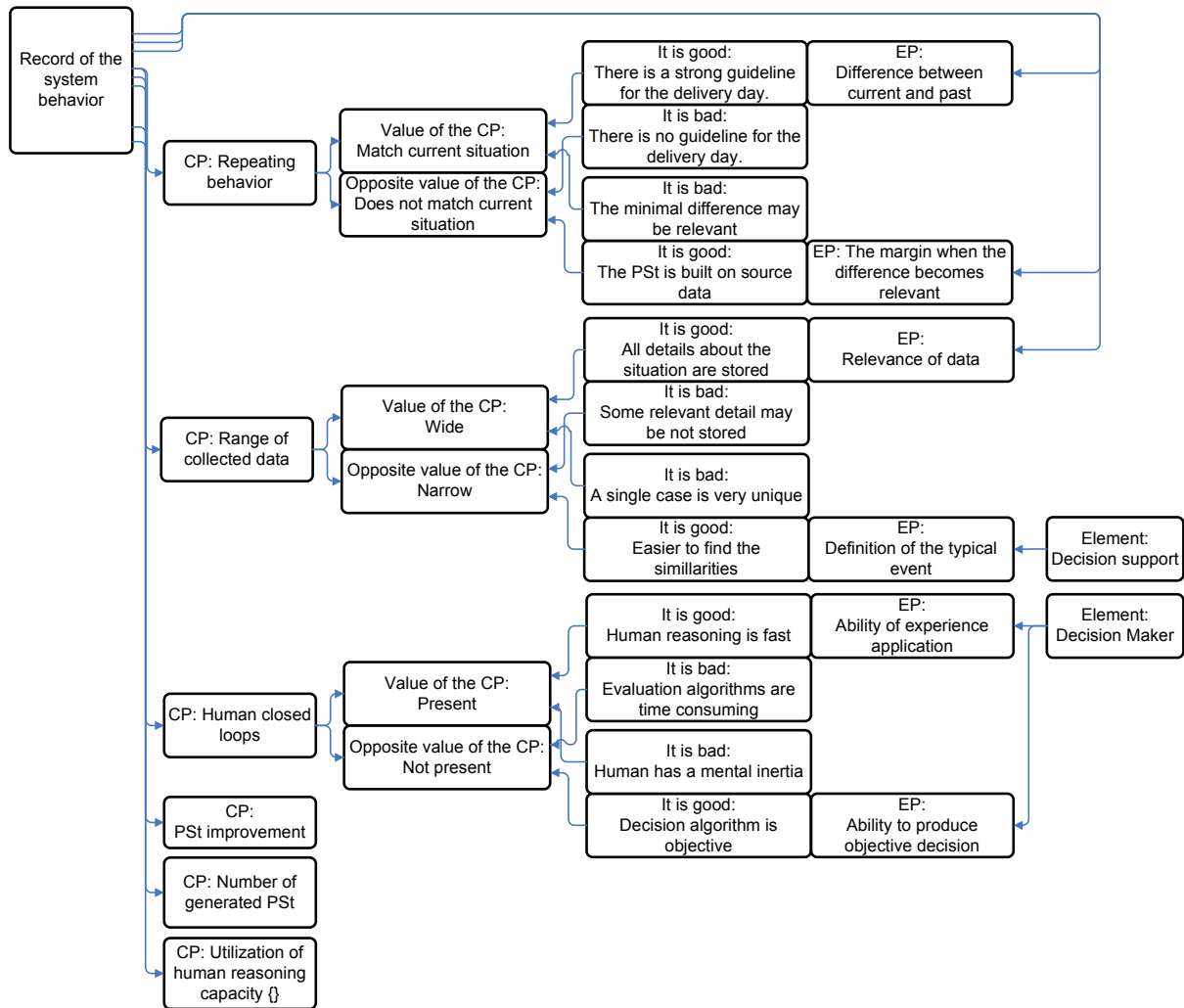

Figure 55. Network of contradictions – objective: utilization of the record of system’s operation in order to improve the production strategy.

## 2.4.5 Synthesis – construction of the network of contradictions

The network of contradictions is a concept from the OTSM-TRIZ. The construction of the network follows the set of rules proposed basing on the available knowledge, consultations and experience. The concept of the networks of problems and network of contradictions benefits significantly to the analysis of the system. It is possible to distinguish following stages in application of the networks’ concept:

1. Construction of the network of problems,
2. Selection of the key problems in the network of problems,
3. Construction of the network of contradictions,
4. Selection of the key contradictions,
5. Analysis of the relations in the network of contradictions.

## 2.5. Synthesis

Organization of the knowledge about the elements of the system and the relations between them is a task addressed in the information management tools. The construction of the knowledge base in these tools is developed in parallel with the exploration of the system of problem. As the exploration of the system advances, the information management tools become more and more complete and full of information. Then they can be used as a map of the system's analysis. For example, the structure of the network of problems or network of contradictions provides the view on the problems identified in the system and relations between them, but they provide also the link to the knowledge used to describe these problems e.g. in the form of contradictions.

## 3. Description of the system

This section presents the review of the information obtained through utilization of the analysis tools. The pieces of information are formed into the description of the system of problem of the PSt preparation process. The description of the system uses results from the analysis tools. These description is completed with the necessary data collected to support the analysis tools i.e. data necessary to setup the analysis tools e.g. description of the process sequence.

The information collected here is used to form the IDEFØ diagram presenting the engineering system of PSt preparation process. The content of this section together with the previously performed analysis, is the support in the search for the key problems using e.g. IDEFØ, network of problems, network of contradictions.

### 3.1. Input, output of the system elements

#### The system of the PSt preparation

The system of the PSt preparation contains three main elements:

1. Data collection
2. Decision making
3. Scenario computation

These three elements are linked by the process of PSt preparation. The product of the process is the production strategy (PSt).

#### Data collection

The main function of the data collection element is evaluation and organization of the data, in order to transform them into the information. At the input to this element there are data describing the environment of the energy production system. The main groups distinguished in the data set are:

### Group 1

Performance data of production units e.g. power of the boiler [MW], steam mass flow [kg/s], transportation capacity of electricity grid. lines.

### Group 2

Data describing current state of the environment e.g. weather, contracts for fuel [€/m<sup>3</sup>], current production commitment, production system state

### Group 3

Forecasts (the future state of the environment) e.g. weather, heat load [MWh], electricity load [MWh], energy market price [€/MWh]

At the output of the data collection, data are put into the model (element #1 S3L2 Table 17) or used in the decision making (element #2 S1L1 Table 17). Data are transferred to the next stage of the PSt preparation process in the form of evaluated information. The quantity of data is reduced thanks to the conclusions made in the data processing e.g. weather forecast, price forecast, state of the energy production system.

## Decision making

The input to the decision making element are the pieces of information in the processed form. They describe the particular situation conditions, where the system for energy production is going to work following the instructions given in the PSt. For the decision making element the indispensable is the knowledge of the configuration of the energy production system i.e. electricity production units, heat production units, relations between elements etc. This knowledge is in the resources of the decision maker (DM) as his/her experience and skills. In the exact form these information are present in the system in the form of model of energy production system with trading elements.

The main function of the decision making element is the preparation of the production scenario. The production scenario contains the decision made for the currently available information and the available knowledge about the energy production system and energy trading options. The production scenario includes variants, automatically generated according to the instructions in the scenario. (each variant undergoes computation process)

## Scenario computation

The product of the decision making element, the production scenario, is an input to the scenario computation. This element of the system merges the data collected in the data collection element and the model of the energy production system with the instructions given in the production scenario. This set is the complete setup model in the current situation. This is the core of the production strategy (PSt) because the result is already present in the setup model and it will be found through the optimization. Together, the complete set of data, in the form of matrix, is ready for computation in the mathematical solver. The function of the scenario computation is computation of the production scenario by means of optimization algorithms. The output of the scenario computation is the PSt with the calculated expense of the energy production following the production scenario prepared in the decision making element.

## Relation between elements

All three elements, data collection, decision making and scenario computation, are on the equal level of hierarchy in the process. In the single execution of the PSt preparation process

all elements act one after another. The decision making element is here the one, which initiates the process. It demands the data from the data collection element and supplies the production scenario for the computation. After the computation, the decision making element receives the results from the scenario computation and decides whether to initiate the new process for PSt preparation, with the new production scenario, or accept the output of the current computation. The decision is made basing on the priority to maximize the profit of the GENCO. Variants included into the scenario are computed one by one without the analysis of the results. Variants are generated automatically according to the main idea formulated in the production scenario e.g. even spread of values in the predefined range. The results are analyzed after the computation of the complete set of variants in the production scenario. For instance, production scenario includes 10 variants.

### Parameters describing the system

The process of the PSt preparation can be described with following parameters. (Table 12)

Table 12. Example of parameters describing the system

#	Name of the parameter	Description of the parameter
1.	Number of repetitions	<p>In case the produced PSt is not accepted by the decision making element, the process is reinitiated with the different production scenario. The number of repetitions refers to the whole system and shows how many times it should be run to produce accepted PSt.</p> <p>This parameter depends highly on two facts:</p> <ul style="list-style-type: none"> <li>○ The decision making element needs several repetitions to make a judgment.</li> <li>○ The method for PSt preparation is the Scenario Analysis requires several repetitions.</li> </ul>
2.	Total time	<p>It is a sum of the time consumed by each element: data collection, decision making and scenario computation. The total time depends on the method for the PSt preparation. The method applied in the existing system, the scenario analysis, requires several repetitions of the entire process. The total time counts for the period from the start, until the moment when DM accepts the final PSt. In order to accept the PSt the DM evaluates the realization of the profit maximization objective and the risk level.</p> <p>The total time is limited by the time frame ending with the start of the trading session. The bids should be deposited before. The beginning of time is limited by the current data availability i.e. the closer to the trading session the more current data are used. In practice there is approximately one hour for the PSt preparation.</p>
3.	Number of human closed loops	<p>Human intervention in the system provides the decisions to initiate and to terminate the PSt preparation process but it also causes delays. Elements including the human element are data collection and decision making. Only the scenario computation is free from the human intervention and it is realized by means of the mathematical algorithms.</p>
4.	Number of data	<p>The number of data refers directly to the data in the matrix, the final form of the setup model before computation. The model of the energy generation and trading is built out of elements representing the real system. These elements demand the data in order to make the model up-to-date for the current conditions. The number of the data refers then to the data about the model's structure and the data about current conditions.</p>
5.	Computation time	<p>Computation time is measured for the scenario computation process. It depends highly on the computation hardware performance, computation algorithms and the number of data.</p>

### 3.2. Subsystem of the data collection

The subsystem of data collection includes three elements, connected into the process of data collection in the following order (Figure 56):

- Element #1 Data acquisition (main function: to collect data is data input)
- Element #2 Data processing (main function: to extract information from the data)
- Element #3 Data output (main function: to form data into the thematic reports)

Data acquisition is split into several elements dedicated to the particular sort of data required by the super-system e.g. weather data, historical record of energy consumption data, working parameters of the production units. Acquired data pass to data processing including again several sub-systems dedicated to the particular sort of data e.g. weather data and historical records are used for the heat load forecast preparation. It is in the data processing where the data are converged into the information used in the decision making element of the super system. Major part, of the processed data, is used in the decision making element. The other sets of data e.g. working parameters of production units or data describing the production system’s state, are feed directly to the matrix, the element of the computation system. Both sets of data, the one used in the model and the other used in the decision making, can be named as a database for the PSt preparation process.

The environment of the system can be described with multiple data, therefore the set of data is limited by they relevancy. In order to deal with the relevancy of data, the excessive amount of data is applied. The other boundary is the time of current moment. The collected data can not be more up-to-date then for the current moment, passing this moment we are dealing with forecasts.

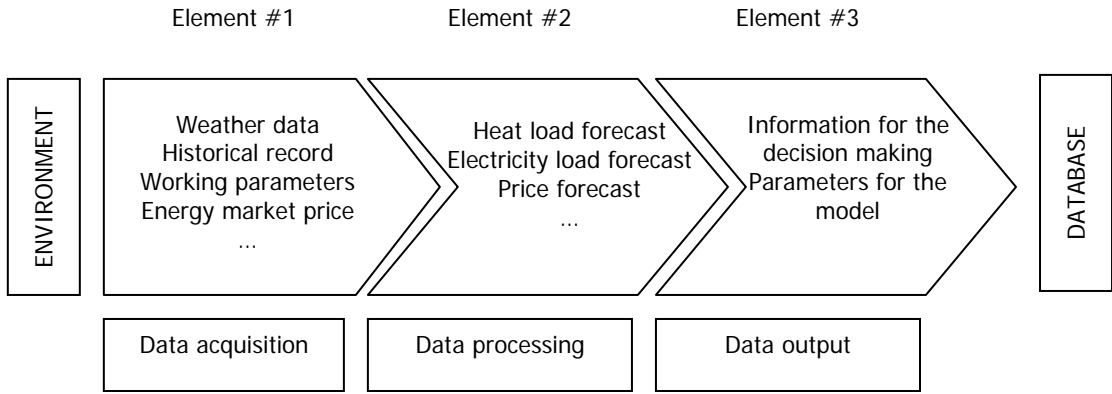

Figure 56. Data collection element - subsystems

Outside the data collection process, it is linked to the following elements – see Table 13

#### Parameter describing the data collection – The number of collected data

This parameter refers directly to the data collection element of the system. The parameter shows the number of data, which are indispensable in the particular PSt preparation process. Increase in number of data increases also the need for service applications to process them. Higher number of data and increased number of processed information, have an impact on the decision making element, which will have to deal with large number of data.

Table 13. Relations with the elements

Element	Description
The super-system, environment	Data acquisition elements are linked at the input end with the super-system, the environment.
Decision making	Data are requested for the preparation of the production scenario.
Scenario computation - output	Computation results of the scenarios computed in the same session are put into the database as a resource for the next production scenario.
Model of the energy production and trading system	Parameters of the production units are put into the model, they are fixed for the whole session i.e. the characteristic parameters of e.g. turbine, boilers

### 3.3. Subsystem of decision making

The information from the data collection element and the knowledge of the system, all together they do not deliver the sufficient information to make directly the production scenario or the PSt. There is a need for the decision making process as a subsystem in the decision making element, to prepare the production scenario. Analysis of the data and preparation of the production scenario is the main function of the decision making element.

The decision making process organized in the loop is closed with the decision maker (DM), who makes a modification to the scenario. The scenario is put for the computation in the next run of the loop. (Kohlmeier, Ressenig et al. 2003) The DM, also called energy expert, is supported with several tools to analyze the results, system conditions, contracts and forecasts. (Scheidt, Jung et al. 2004) The decision making process is using the data collected at the ‘data collection’ element to form the production scenario. (Figure 57)

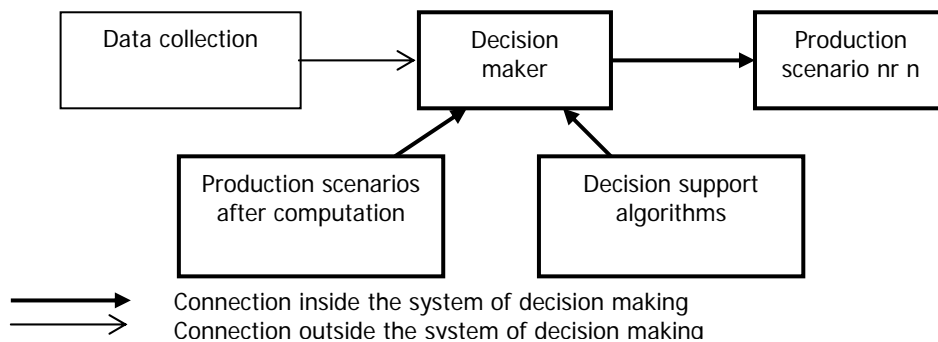

Figure 57. Decision making process – preparation of production scenario nr n

The important boundary of the system of decision making is time. The PSt should be produced during the approximately 1 hour session. The end of time for decision is fixed. Other boundaries for the decision making are the trading options, defined by the energy market and physical limitations of the energy generation system. For instance in the reaction to the increased demand, it is not possible to start-up the turbine quicker then the start-up time e.g. 45' for gas turbine.

Outside the decision making process, it is linked to the following elements – see Table 14.

Table 14. Relations with the elements

Element	Description
Data collection	Connection with the sources of the input data (including results of the scenario computation, the PSt computed in the same session)
Model	Delivery of the production scenario and supplementary instructions e.g. arrangements in the model

Parameters describing the decision making process:

- time – it is limited as a part of the total time,
- number of processes including the human decision (DM element),
- number of repetitions of the PSt preparation process until selection of the final PSt.

### Sub-system of the DM

The DM can be considered as a system including several elements. As DM is a human, the rules applied by him do not follow a strictly defined method. Elements of the DM system, listed in Table 15, include resources as positions #1 through #4. Element #5, the concept of the production scenario, is an output. In order to produce the concept, DM is using the database to create the temporary forecasts and planning. Forecasts are being compared with the planning and enhanced using the data from the database and skills of the DM e.g. experience, analytical skills.

Table 15. The subsystem of the Decision Maker (DM)

Element	Name of the element of the subsystem
#1	Current data evaluation DM reviews data describing the current situation conditions including the conclusions of scenarios already computed in the current session. Parameter: Number of reports from the data collection element. The basic set includes 4 elements: electricity load forecast, heat load forecast, price forecast and system's state.
#2	Historical record DM can learn from the historical record about the production system's behavior e.g. periodical events, particular situations and exceptional events. Parameter: Number of years in the historical record, number of typical events referring to the current situation
#3	Skills (the knowledge with the ability to apply it) Parameter: Measurable by the rank or certified skills.
#4	Experience Experience of the DM gained from the operation of the energy generation system in various situations and periods, increases the ability to produce the production scenario, using the method of scenario analysis.
#5	Concept for the set of scenarios

The process of decision making is closed in the loop repeating the evaluation of forecast and planning plus utilization of the database. (Scott Armstrong 1983) (Figure 58) Concepts formulated in the planning and forecasting are stored in the database which is used in the creation of next alternative planning and required forecast. The final output is the concept of the production scenario, the formalization of the DM's decision. The decision about the production scenario is the main function of the DM. (Figure 59)

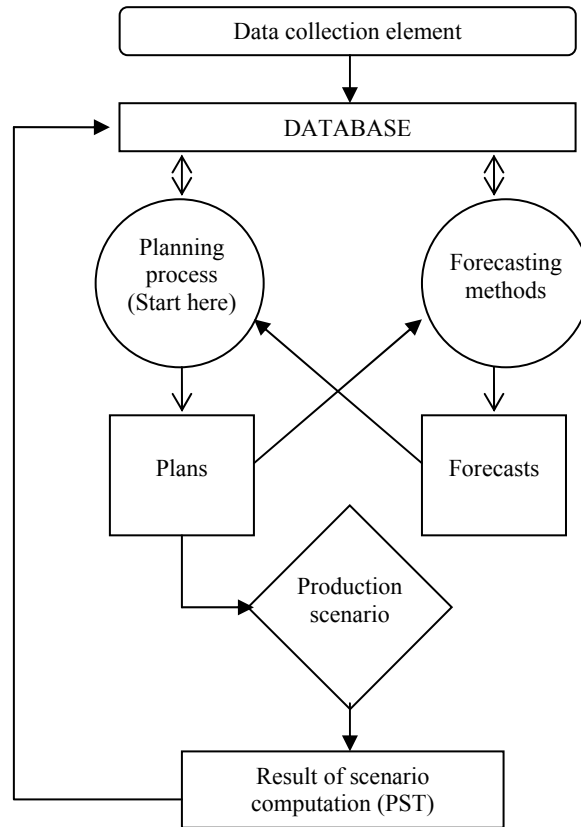

Figure 58. Planning and forecasting (Scott Armstrong 1983)

As the DM is a human, the limitations of DM include skills, experience and the human capacity for analytical reasoning. The other human limitations include also: need of high level training, temporal exchange of the staff, specific training and experience assigned to the particular type of energy plant, ability to learn, personal biases, situational awareness, mental inertia.

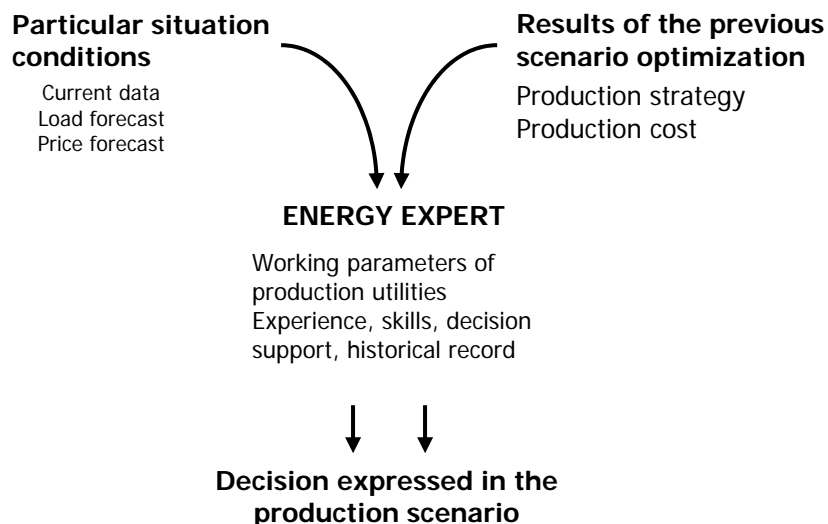

Figure 59. Position of the DM – data flow diagram

The DM is required in the decision making process because he provides the fastest evaluation of the capabilities of the energy generation system under the current conditions



described by e.g. heat and electricity load forecasts, price forecast, weather conditions. The evaluation made by the human DM is not optimal. The replacement of the human DM by the decision making algorithm is one of the subjects for the further research.

### 3.4. The subsystem of scenario computation

The system of production scenario computation includes 7 elements described in Table 16. They are linked by the process presented on the (Figure 60).

Table 16. Elements of the subsystem to Scenario computation

#	Element	Description
1.	Model	Representation of the real system of GENCO including trading elements.
2.	Matrix setup	The matrix contains the mathematical representation of the model in the form of functions and arguments organized into the rows and columns. The matrix setup is a process where all data from the model are transformed into the form of functions and arguments.
3.	Simplifications	Simplifications, is the process performed on the functions representing the elements of the production system, in order to reduce the amount of data e.g. two boilers of the same parameters working at the same time, are represented by one function instead of two. (Icking, Lucht et al. 1994)
4.	Aggregation	Aggregation is a mathematical preparation of the matrix before the data are put into solver.
5.	Solution	Solution is computed in the mathematical solver using the up-to-date technology e.g. CPLEX. The main function of this system is to find the optimized solution for a task in the form of mixed integer problem (MIP) given in the matrix.
6.	De-aggregation	Transformation of the optimization result in order to read the result for the particular functions.
7.	Result interpretation	Results are delivered in the form requested in the model. (Scheidt, Jung et al. 2004)

#### Element #1 – Model

The main function of the model is representation of the real system for energy generation and trading. Elements of the generation system are represented as mathematical functions. The elements of the model include places for all necessary data to describe the real system and the particular situation conditions e.g. parameters of the production units, production load. The model becomes complete when the data from production scenario are put into the model.

Elements of the model can be put in two groups, one is the group of technology elements e.g. energy generation units, energy transportation utilities etc, second group is the trading group composed of trading elements e.g. fuel contracts, electricity selling options (e.g. block contracts). These two groups have also a reflection in the production scenario, which includes the data about the technology and elements of trading. However the trading part of the model is not sufficient to control the solution in energy market trading, it has here a complementary role.

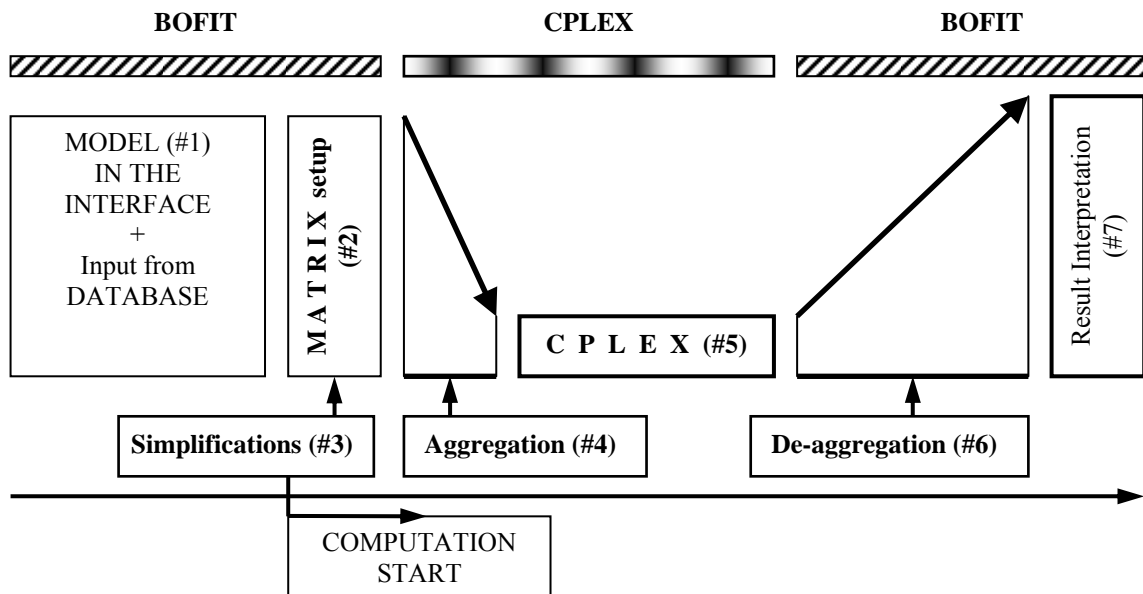

Figure 60. The computation process decomposed into stages (The numbers correspond to the Table 16)

#### Subsystem of the Matrix Setup – The Matrix

Before the model is put into the matrix, it is accessible through the user interface with graphic representation of elements linked with the database (here a data storage). Matrix contains the mathematical form of the model. Functions describing the system's elements and data setup for the particular production scenario are put into the matrix as functions and arguments.

Parameters describing the matrix (example):

Number of columns 20 000

Number of rows 60 000

Number of nonzeros 5÷10%.

#### Subsystem of the Solution

The subsystem in the Solution element is the mathematical solver. Solver is a commercial product applying the state-of-the-art optimization algorithms to find the solution of the problem presented in the matrix e.g. CPLEX.

Boundaries of the system of scenario computation are linked with the limitations of the mathematical solver and the computation hardware. However these boundaries are moving i.e. optimization algorithms are being developed and the performance of the computation hardware keeps on growing.

### 3.5. The summary of systems and sub-systems

The complete description of the system and its elements is presented in Table 17.

Table 17. System and subsystems with elements

System reference: System Level	Name of the system- function of the system (or properties)	List of elements of the system	Relations with semantic meaning of relation between elements
S1L1	System for PSt preparation	<ol style="list-style-type: none"> <li>1. Data collection</li> <li>2. Decision making</li> <li>3. Scenario computation</li> </ol>	#1&#2 transfer data in the processed form between elements #1→#2→#3. #3 delivers the product of the system and sends it to #2.
S1L2	Data collection	<ol style="list-style-type: none"> <li>1. Data acquisition</li> <li>2. Data processing</li> <li>3. Data output</li> </ol>	#1 supplies data in groups to specific analysis in #2. #2 produces results sorted in #3.
S2L2	Decision making	<ol style="list-style-type: none"> <li>1. Scenarios computed in the same session</li> <li>2. Decision support algorithms</li> <li>3. Decision maker (DM)</li> <li>4. Production scenario</li> </ol>	#1 collects products of the S1L1 to deliver additional data for #2&#3. #2 uses the products of S1L2 to support #3. #3 requires the data from #2,#3 and S1L2 to produce #4.
S1L3	Decision Maker (DM) – decides on the production scenario	<ol style="list-style-type: none"> <li>1. Current data evaluation</li> <li>2. Historical record</li> <li>3. Skills</li> <li>4. Experience</li> <li>5. Concept for the set of production scenarios</li> </ol>	#1 through #4 have to be present to be used by the DM system (S1L3) to produce #5.
S2L3	Production Scenario – expression of the DM decision	<ol style="list-style-type: none"> <li>1. Technology efficiency</li> <li>2. Trading efficiency</li> </ol>	#1&#2 are objectives in contradiction with each other
S3L2	Production scenario computation	<ol style="list-style-type: none"> <li>1. Model</li> <li>2. Matrix Setup</li> <li>3. Simplifications</li> <li>4. Aggregation</li> <li>5. Solution</li> <li>6. De-aggregation</li> <li>7. Result interpretation</li> </ol>	#1 is a destination of the S2L2 product. #2 puts the #1 of S3L2 into the form of matrix. #3,#4 are the algorithms acting on the matrix one after another. #4,#5,#6,#7 are activated in presented order. Each use the output of the previous element.
S1L4	Matrix Setup – setup of the mathematical form of the model	<ol style="list-style-type: none"> <li>1. Matrix</li> </ol>	#1 collects data from #1 in S3L2 and #4 in S2L2. #1 is formed to fit the requirements of the solver in #5 of S3L2.
S2L4	Solver – applies advanced mathematical algorithms to compute the solution	<ol style="list-style-type: none"> <li>1. Advanced mathematical algorithms</li> </ol>	#1 uses the processed task from #4 in S3L2 to deliver the result which is interpreted in #6&#7 of S3L2

#### 4. Strengths and weaknesses in the application of analysis tools

The strengths and weaknesses perceived in the utilization of the particular analysis tools during the research performed in the thesis, are arranged using the SWOT concept (Strengths Weaknesses Opportunities Threats). The SWOT concept is organized into the Table 18 presented in Appendix 2 page 162.



---

## Chapter 5. Synthesis and generalization: proposed approach

---

This chapter presents the contribution of the thesis to the problem of analysis of the complex system of problem and comprehension of the system of problem based on the physical system of the energy production strategy preparation. The proposed method integrates several analysis tools in order to increase the knowledge about the analyzed system returned from the proposed analysis process. (Figure 61)

Part one: proposes the new approach to the analysis of the complex system of problem.

Part two: conception of utilization of the method

Part three: validation of the research performed in the frame of the thesis

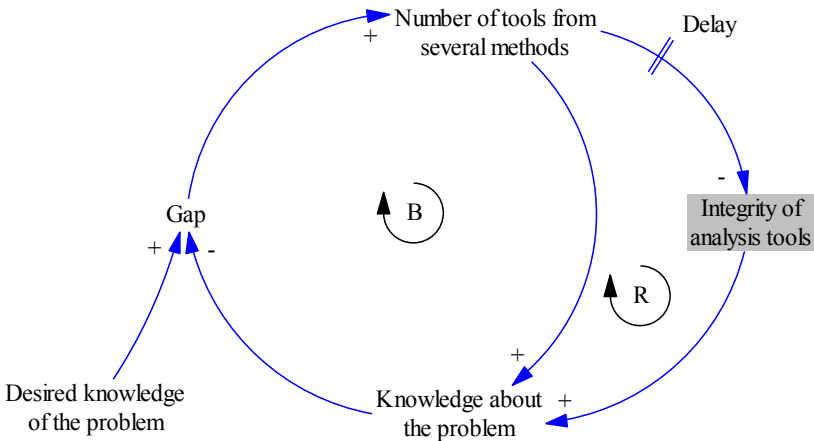

Figure 61. Causal Loop Diagram (CLD): Utilization of various analysis tools; Archetype: Fixes that fails

### 1. New approach

#### Origin

It had been decided at the beginning that the analysis of the complex system will not be performed by the means of single approach as it is usually done, but rather by the means of several approaches applied according to the particular needs. It had been also decided, that the set of the analysis tools is not restricted before the analysis begins. With these rules, the analysis starts with the most convenient analysis tools and continues applying the tools which are the most useful. In this way the method for analysis of the complex system, is created gradually throughout the process of the analysis.

The analysis is performed on the physical system of the process of preparation of the energy production strategy. The analysis of the system is supported by the example software with models of the energy production systems for urban areas, available thanks to the ProCom GmbH. The software BoFiT TEP and the procedures of its application have been used as means to learn about the system for energy strategy preparation.

The conditions created for the analysis of the system of problem can be described by three features. First, the new analysis method applies several analysis tools in order to satisfy the incentive to benefit from the advantages of diversified tools. Second, the set of the analysis tools which are applied inboard of the method is open, it is possible to use analysis tools chosen individually for the particular situation. Third, the application of the chosen tools outside of the procedure of some complete method may require to use them repeatedly.

These three points show that, although there is an advantage of such approach, there is a lack of the system of control. The proposed method introduces the system of control to the method of the complex system analysis.

### Principle

The principle of the new approach to the analysis of the system is the introduction of the means to control the process of the analysis. The control is required for efficient use of the several analysis tools composing the method and to manage the information generated by the entire method of analysis.

The control over the analysis process has three foundations. The first one is the utilization of analysis tools for the exploration of the complex system. The second is the utilization of the analysis tools for the guidance of the analysis process during the analysis. The third fundamental element is the management of the information obtained throughout the analysis process. An additional rule of the method says that the set of the analysis tools is not restricted. During the application of the method, several analysis tools can be used and their application can be repeated according to the need.

The proposed method of analysis of the complex system of problem is based on the three principles:

1. Utilization of unrestricted group of simple analysis tools for the exploration of the system.
2. Guidance of the analysis process by the means of analysis tools to collect and organize the knowledge.
3. Management of the results for the comprehension and operation of the analysis of the entire system.

The analysis tools which serve the first principle are presented in Chapter 4 in points: 1.1 and 1.2 with the inclusion of second principle in 'knowledge capitalization sections' located respectively in 1.1.3 and 1.2.5. The utilization of the third principle is realized in point 2.

### User

The user of the method should build the initial knowledge database about the system which he/she is going to analyze. The construction of the knowledge starts from the analysis of the initial problem. In order to understand the initial problem and to start to describe it, the knowledge base starts to be constructed. The knowledge is consolidated thanks to the particular pattern of the applied analysis tools. The knowledge base is a background for the system of problem, because it is used to describe and position problems in the system.

The user, basing on his/her experience chooses the analysis tools which are applied in course of the analysis. The extent of the application of the analysis tools from three groups, at the basis of the method, is also up to the user. The analysis tools from three groups have to be used in order to maintain control on the process, but the user decides how much focus on the particular group in order to obtain the best effect.

### Objective

The subject of the thesis is to construct the method for the complex system analysis, using the example of the complex system for the energy production strategy preparation. The solution in the proposed method has the following objectives:

- Provide the control on the application of the several analysis tools and on the results from their application.
- Help in the comprehension of the system for energy production strategy preparation.

### Functions

The functions introduced by the method works on the three defined foundations of the method and the knowledge database:

- Guidance of the analysis tools used for the exploration of the system,
- Collection and organization of the information generated through the guided application of the analysis tools,
- Operation of the results from the analysis – to guide the analysis, in order to communicate internally and externally for the better understanding of the system containing problems from different domains (multidisciplinary).

### Structure

The structure of the proposed method can be described by the three features: analysis tools, organization and process of application.

#### Analysis tools

Analysis tools are chosen according to the need during the analysis process, the example set of tools, used for the analysis of the case in this thesis is presented in Table 7 and Table 18.

#### Organization

The method is organized around three points, the exploration of the system, guidance of the analysis and the management of the results.

#### Process of application

Application of the proposed approach is conducted by the user who controls the progress of the analysis by the operation of three basis of the method. The application of the method provides the progress in the analysis and comprehension of the analyzed system of problem.

## 2. Utilization of the method

### Capturing the information

Collection of the information takes place especially at the beginning of the analysis process. The knowledge base has to be constructed. It is recommended to use simple analysis tools

with short procedure of application. The information is captured through the following activities:

- Collection of the data in order to describe the problem,
- The description of the problem e.g. using the model of contradiction,
- Utilization of the analysis tools, which stimulate the collection of information along the sequence of application of the particular tool,
- Utilization of the guidance tools and the information management tools e.g. Multi Screen Scheme of Inventive Thinking, Network of problems.

### Work on the information – analysis and guidance

The progress in analysis is achieved by the acquisition of logical connections in the pieces of information about the system. This includes the information about the elements of the system, involved in the particular situation where problem appears and information about the relations between elements. During the exploration part of the method, the user works on the information using the results from one analysis tool to the following analysis tool. The picture of this process is obtained thanks to the application of the guidance tools e.g. Multi Screen Scheme or CLD, proposed in point 1.1.3 and 1.2.5. The ultimate overview and work on data obtained through the analysis is realized by the information management tools e.g. network of problems, IDEFØ, network of contradictions, presented in point 2.3 and 2.4.

### Capitalization

The knowledge capitalization has two objectives. One is the collection of the results from the application of the analysis tools for the reuse within the analysis process. The second objective is the management of information about the entire system. These objectives are performed by the tools from second and third foundation part of the method:

- Utilization of the guidance tools
- Utilization of the information management tools

Moment at which the knowledge is capitalized:

- Application of the analysis tool,
- Integration of the result into the knowledge base,
- Construction of the knowledge management structures e.g. network of problems, IDEFØ.

### Reutilization

The information about the system, elements, constraints and relations, are constantly reutilized:

- during the exploration stage when using the results from one analysis tool to continue the analysis with the other analysis tool,
- in the utilization of the guidance tools, the results and knowledge base are used to build a picture of the explored system,
- management of information builds a map to operate the knowledge about the system and also stimulates the research in new directions in order to complete the picture.

### Management of information

The flagship examples of the information management tool used in the research presented in the thesis are the Multi Screen Scheme of Inventive Thinking (System operator) and the



Network of problems. Both come from the OTSM-TRIZ. They can be constructed during the analysis of the system. The system operator is used mainly for its guidance feature. The network of problems performs two functions:

- it is used to collect, visualize and stimulate the exploration of information about the system during the analysis,
- it is an intermediate stage to construct the network of contradictions.

The network of contradiction brings the management of information to the next level. This is in fact the work on the collected and managed knowledge about the system. The process of transition to the net of contradictions including selection of key problems, declaration of objectives and formulation of contradictions, consolidates the knowledge and comprehension of the system of problem.

### 3. Validation

We would like to present here the validation of the two major applications of the proposed solution in the method of analysis. First application it is the utilization of the approach to analyze the problem used in the research. Additionally, steps for the validation process, by application to the different problem, are also presented below. Second application is the comprehension effect, which is achieved by the application of the particular tools from OTSM-TRIZ.

#### By application

The proposed solution in the method of analysis is applied to the example case of the process of preparation of the energy production strategy. The analysis of the system of problem presented in the thesis in Chapter 4, has two objectives. First objective is the amelioration and intensification of the idea of the method founded on three basis presented above, by the application to the analysis of the physical system. The second objective is the illustration of the results from application of the proposed method of analysis.

The features realized in the application of the proposed method for analysis of the system of problem:

- combination of the required analysis tools,
- application of several analysis tools,
- solution for the inconvenience in application of several tools, by the introduction of the information management tools,
- construction of the method during the analysis,
- the method is adapted to the particular physical system – the system of the process of preparation of the energy production strategy,
- information management facilitates the comprehension of the system and communication of results.

Useful features recognized in the application of the proposed method to the specific problem:

- IDEFØ was used for the joint presentation in the one scheme (in several layers), of the relations in the developed structure of physical system e.g. technology system, energy trading system and relations with the system of problem e.g. definition of the engineering problem and the problem in the method. (Figure 52 p.117)

- Search for the next bottleneck helped to analyze the structure of several systems e.g. it moved the analysis from the system of computation process to the system of the decision making process.
- Construction of the network of problem and network of contradiction consolidates and guides the development of the knowledge about the different regions of a system e.g. system of the production technology, system of decision making, system of energy trading.
- For the entire method the most useful is the cross-integration of the analysis tools from three proposed groups of problem exploration, analysis guidance and information management, the effect is for instance: operation of the collected knowledge from the level of the network of contradictions.

#### Application to the cases different then the one in the thesis

The proposed solution in the method of analysis can be validated by the application to the analysis of a problem different then the one employed in the thesis. In order to perform such a validation, follow the steps of the method's application process:

1. Define the initial problem.
2. Define the physical system where the problem appears.
3. Use the convenient analysis tools for system exploration.
4. Collect the data.
5. Use the guidance analysis tools which will guide the exploration process of a system of problem.
6. Collect data and organize them with the information management tools.
7. Use the managed information for the further exploration and guided analysis.
8. Complete the information management tools with obtained information.
9. Work on the knowledge organized in the information management tools, select the key problems.

The application of the method of analysis is complete when the information management tools are constructed and used in the course of the analysis. The information management tools support the selection of the key problems and description of their role in the constructed system of problem. In the further step, key problems are used to prepare the propositions of solutions.

#### By comprehension effect

The application of the method for problem system analysis, according to the proposed solution, provides the control over the knowledge of the analyzed system, its elements and relations between elements. This effect gives the user the ability to understand the problems which appear in the system or which will appear in the future. It proposes also the tools to look for the solution of analyzed problems. The description of the last stage of the information management, which in this case was the construction of the network of contradictions, presented in point 2.4 Chapter 4, presents the operation of the knowledge about the system of problem, from the level of network of contradictions. The ability to comprehend the system has been achieved thanks to the utilization of the particular analysis tools from the OTSM-TRIZ. The tools were used in all three regions fundamental for the proposed method. The

most important for the comprehension ability was the utilization of the model of contradiction, technique of construction of the network of problems and the network of contradictions. The ability to comprehend the analyzed system, the user achieves at the end of the analysis process with the construction of the network of contradictions, which is also used as an analysis tool for the information management.

The effect of the system comprehension can be observed and followed from the end of the analysis process presented in Chapter 4, from the point of view of the network of contradictions.



---

## Chapter 6. Conclusion and perspectives

---

The contribution of the presented work is divided into two parts. One of them is in the methodology for the analysis of the complex system of problem. Second is in the comprehension of the analyzed system of problems.

### Method for the analysis of the complex system

#### Synthesis

The solution in the method for the analysis of the complex system has been proposed in the thesis. The objective of the method is to deal with the complexity of the system of problem by the application of several analysis tools instead of the utilization of a single approach. Organized application of the unrestricted set of analysis tools creates in fact the new approach, but without limits of the single method. The analysis process presented in the thesis applies mainly the analysis tools from the OTSM-TRIZ theory, with the support of CLD from System Dynamics and the concept of the IDEFØ diagram. The individually constructed method deals with the following aspects of the complex system analysis:

- This method addresses the complex system including many smaller systems from different domains, which require the specific knowledge to work with them.
- It organizes the analysis process in order to address the problems located in different domains and to capture the big picture of the analysis and the system.
- It provides the control over the knowledge base built during the analysis process.

The construction of the method was supported by the analysis of the real physical system of the process for preparation of the energy production strategy. The process was analyzed basing on the example models of the urban energy production systems built and operated in the software tool BoFiT TEP. The information about the localization of the process in the larger scale was based on the procedure of utilization of the BoFiT TEP and similar software tools.

#### Contributions

This method answers to the needs formulated in the scope and aim of the thesis:

- It is constructed during the analysis process.
- It introduces the joint utilization of various analysis tools inboard of the one method.
- It maintains the control over the analysis process, by the application of the guidance tools during the process and construction of the information management tools used to work with the complete picture of the results from analysis.

Comparing to the compact approaches presented in the introduction (Chapter 1, point 6), the proposed method is better adjusted to the needs of the physical system analyzed in the

thesis. These objectives are realized by the introduction of the new rule, to use the analysis tools providing three described features i.e. system exploration, analysis guidance and the information management.

This solution in the method construction imposes the regulation in the process of analysis but at the same time it leaves the free choice in what sort of analysis tools will be applied and how many of them. In this way the process of analysis can be freely adjusted to the different kinds of systems and smaller systems (smaller systems coming from different domains) included into the main system. Information management plays an important role in the proposed method. Towards the end of the analysis process, the analysis is focused on the operation of the information management tools. Thanks to these tools it is possible to see through the whole knowledge about the system of problem and to focus on the key issues, key problems and their solution.

### Limits

During the analysis process performed on the physical system of the preparation of the energy strategy, a limitation has been noticed. The set of the analysis tools selected for the application depends on the individual preferences of the user. The user will apply the most likely the tools which he/she is familiar with, then the other recognized tools. The current solution does not provide the list of proposed analysis tools which can help in diversifying the choice of tools and thus offering the better fit to the analyzed system. In the current form the method relies on the experience of the user in the selection of the analysis tools.

The other limitation can be also the pace of the analysis, which is not determined. The tempo of the analysis process is not set because of the free choice of analysis tools. It is up to the user how many analysis tools he/she applies and how many times.

### Perspectives

The first perspective for the further research concerns the preparation of the rules which support the construction of the method profiled for the analysis of the particular kind of the complex system. Such a method may propose the utilization of the particular analysis tools, which set up the basis for the method in order to make it more efficient for the particular category of system e.g. designing process, production process management.

The other perspective is to work on the preparation of the algorithm form of the method. The objective of this direction of development would be to describe in the form of rules and concepts, the activities of the user of the method. The formulation of the algorithm may reduce the role of the human element in the basic activities and hence improve the focus of the user on the key decisions in the utilization of the analysis approach.

### Comprehension of the analyzed system

The second part of the contribution is the utilization of the method for system analysis as a set of tools and procedure to achieve the comprehension of the system of problem of the preparation process of the energy production strategy in a GENCO.

### Synthesis

Proposed method for the system analysis provides the systematic way to analyze the complex system of problem. In the course of this analysis we have applied tools for the

information management. Information management improves the quality of the analysis method in management of results and the understanding of the analyzed system. In consequence the knowledge about the system acquired from the application of analysis tools is organized into the comprehensible structures e.g. system operator, IDEFØ, network of problems. The knowledge is reused in the further analysis tools and capitalized in order to create the map of knowledge of the analyzed system.

Comprehension of the system is based on the knowledge about the:

- elements of the system involved,
- relations between the elements.

In order to build this knowledge, the proposed method for complex system analysis applies the analysis tools with the scheme of three functions which have to be provided i.e. exploration, guidance, information management as it was described in the first part of this chapter.

### Contribution

One of the foundations of the solution introduced in the proposed method for complex system analysis, is the information management. Throughout the analysis process the information management tools together with the guidance tools, provide the following features:

- construction of the map of the analyzed system of problem – basing on the described problems and the relations between problems associated with the problem situation – See point 2.4 Chapter 4,
- support in the communication with experts i.e. it is possible to explicitly explain the existing situation, demand the particular information and then integrate it into the map of knowledge about the analyzed system of problem – See point 2.2, 2.3 in Chapter 4,
- it systematizes the links from the key problems to the background data used previously during the analysis - utilization of the network of contradictions presented in point 2.4 Chapter 4.

Comprehension of the system is based on the utilization of the structure created by the information management tools. Thanks to these structures i.e. network of problems, network of contradictions, the essence of the results of analysis, operated by the means of such network, allows at the same time to re-link this information to the data which were used in the upstream of the analysis process. In this way operating the ultimate representation of the problems in the analyzed system the user sees also the large view with interconnections and interrelations in the system.

Together, the analysis tools used for the exploration of the system and the information management, as described above, they gradually present to the user, the picture of the elements and relations in the system of problem. This picture can be used not only for the analysis of the system but also to understand the system of problem with the objective to solve the problem in the current situation. The ensemble of the analysis tools used in the board of the proposed method provides the user with the ability to:

- make the decision concerning the problem or problems in the system,
- construct the tactic to solve the problem,
- adapt the constructed method to the system and use the method in the iterative way in order to improve the understanding of the system and problem solving process.

## Limits

Construction of the tools for the information management depends on the individual approach of the user. In the result the map of problems in the analyzed system presents the individualized view of the user. Moreover it depends on the form of the cooperation with experts and the number of experts who benefited for the system analysis. Individualized construction of the information management makes it sometimes difficult to read by the people not involved in its construction process.

## Perspectives

The ability to build the comprehension of the system can be used to improve the decision making process inside the process of preparation of the energy production strategy. As a result of the analysis of the system of problem of the preparation of the energy production strategy, used in the thesis in order to build the method, the element of Decision Maker (DM) has been pointed as a bottleneck in the existing solution. The key problems described in the information management tools also point on the features related with the human DM. Therefore the method for the improved and applied comprehension of the system of problem may be developed further in order to decrease or eliminate the roles of the human decision maker in the process of the preparation of the energy production strategy for the energy generation system.



---

## References

---

- (1993). Integration Definition for Function Modeling (IDEF0). S. o. Commerce, National Institute of Standards and Technology.
- (2006). "SmartGrids Vision and Strategy for Europe's Electricity Networks of the Future." European Technology Platform. Directorate-General for Research Sustainable Energy Systems:EUR 22040.
- Altshuller, G. (1956-1985). "Algorithm of Inventive Problem Solving (ARIZ-85C)." In English: prepared by OTSM-TRIZ Technologies Center (Minsk, Belarus), 1998-2002.
- Altshuller, G. (1988). Creativity as an Exact Science. New York, Gordon and Breach.
- Altshuller, G. (1989). ARIZ - this is victory. Rules of a game without rules. Petrozavodsk, Karelia: p. 11-50.(In Russian)
- Altshuller, G. (1991). To find an idea: introduction to the Theory of Inventive Problem Solving. Novosibirsk, Nauka. (in Russian)
- Altshuller, G. (1999). The Innovation Algorithm: TRIZ, systematic innovation, and technical creativity. Worcester, Massachusetts, Technical Innovation Center.
- Altszuller, H. (1975). Algorytm wynalazku. Warszawa, Wiedza Powszechna. (in Polish)
- Andersen, A. N. and H. Lund (2007). "New CHP partnerships offering balancing of fluctuating renewable electricity productions." Journal of Cleaner Production(15): 288-293
- Bhattacharya, K., M. H. J. Bollen, et al. (2001). Operation of Restructured Power Systems. Norwell, Springer.
- Bixby, R. E. (2002). "Solving real-world linear programs: a decade and more of progress." Operations Research **50**(1): 3-15
- Bixby, R. E., M. Fenelon, et al. (2000). MIP: Theory and practice - closing the gap. System Modelling and Optimization: Methods, Theory, and Applications. M. J. D. Powell and S. Scholtes, Kluwer Academic Publishers: 19-49
- Bixby, R. E., M. Fenelon, et al. (2004). Mixed-Integer Programming: A Progress Report. The Sharpest Cut: The Impact of Manfred Padberg and His Work. M. Grötsche: 309-327
- Brand, H., E. Thorin, et al. (2001). "Methodology to identify the relevant uncertainties." 5 Framework Programme Contract No. ENK5-CT-2000-00094. (OSCOGEN Deliverable 3.1.). OSCOGEN Deliverable 3.1., <http://www.oscogen.ethz.ch/>
- Brand, H. and C. Weber (2002). "Report on the optimum bidding strategy derived and performance evaluation." 5 Framework Programme Contract No. ENK5-CT-2000-00094. (OSCOGEN Deliverable D 5.2). OSCOGEN Deliverable D 5.2, <http://www.oscogen.ethz.ch/>

- Cavallucci, D., N. Khomenko, et al. (2005). Towards inventive design through management of contradictions. World Conference CIRP 2005, Shanghai, China.
- Dettmer, H. W. "Theory of Constraints: A System-Level Approach to Continuous Improvement." from <http://www.rogo.com/cac/dettmer1.html>.
- Dongarra, J. (2006). "Performance of various computers using standard linear equations software." University of Tennessee:CS-89-85. <http://www.netlib.org/benchmark/performance.ps>
- Fink, L. e. and F. Galiana (1998). Power Systems Restructuring: Engineering and Economics, Springer: 86-88
- Fröck, C., T. Jung, et al. (2003). "Wärmeerzeugung, Gesamtausrichtung der Vattenfall Europe AG, Integrierte Einsatzoptimierung des Kraftwerksparks." Euroheat & Power 32(12): 36-41.(in German)
- Hatchuel, A., P. Le Masson, et al. (2004). C-K Theory in Practice: Lessons from Industrial Applications. International Design Conference - DESIGN, Dubrovnik.
- Hatchuel, A. and B. Weil (2002). La théorie C-K : Fondements et usages d'une théorie unifiée de la conception. Colloque « Sciences de la conception », Lyon.
- Hatchuel, A. and B. Weil (2003). A new approach of innovative design: an introduction to C-K theory. International Conference on Engineering Design ICED 03. Stockholm.
- Hlouskova, J., S. Kossmeier, et al. (2005). "Real options and the value of generation capacity in the German electricity market " Review of Financial Economics(14): 297–310
- Hobbs, Rothkopf, et al. (2001). The Next Generation of Electric Power Unit Commitment Models. New York, Springer.
- Icking, M., M. Lucht, et al. (1994). Unit Commitment and economic Dispatch for large DH-Systems by MILP. International Symposium on Simulation and Operational Optimization of District Heating Systems. Köpenhamn.
- Icking, M., L. Tröster, et al. Dynamic simulation of large DH-systems with regard to heat storage, Universität Dortmund Abteilung Chemietechnik Lehrstuhl für Thermische Verfahrenstechnik.
- Janssen, P., J. Frazer, et al. (2002). "Evolutionary Design Systems and Generative Processes." Applied Intelligence(16): 119–128
- Jayabarathia, T., K. Jayaprakasha, et al. (2005). "Evolutionary programming techniques for different kinds of economic dispatch problems." Electric Power Systems Research(73): 169–176
- Jost, G. (2001). "Untersuchung zur Wirtschaftlichkeit der KWK-Anlagen in Greifswald Gasturbinen-Heizkraftwerk wieder in Betrieb." Euroheat & Power - Fernwärme international(7-8): 56-57.(in German)
- Kaleta, M., W. Ogryczak, et al. (2003). "On Multiple Criteria Decision Support for Suppliers on the Competitive Electric Power Market." Annals of Operations Research(121): 79–104
- Kaplan, S. (1996). An introduction to TRIZ, Ideation International Inc.
- Khomenko, N. and R. De Guio (2005). Utilisation de la theorie TRIZ dans les metiers du BTP. Les cahiers de l'INSA de Strasbourg. R. e. de Guio and S. Dubois. Strasbourg. 1: 10-33.(in French)

- Khomenko, N. and R. De Guio (2007). OTSM Network of Problems for representing and analysing problem situations with computer support. 2nd IFIP Working Conference on Computer Aided Innovation. Delphi Corporation, Technical Center Brighton, USA.
- Khomenko, N., R. De Guio, et al. (2007). "A Framework for OTSM-TRIZ Based Computer Support to be used in Complex Problem Management." International Journal of Computer Applications in Technology In Press, Corrected Proof
- Khomenko, N., E. Schenk, et al. (2006). OTSM-TRIZ Problem Network technique: application to the history of German high-speed trains. ETRIA 2006.
- Kohlmeier, H., A. Ressenig, et al. (2003). "Stadtwerke München optimieren Energieerzeugung." BWK Das Energie-Fachmagazin(3): 32-36.(in German)
- Kucharavy, D. (2003). "TRIZ: Techniques." Workshop printed materials. OTSM-TRIZ Technologies Center, Minsk, Belerus; Laboratoire de recherche en productique de Strasbourg (ENSAIS), France.
- Kucharavy, D. and R. De Guio (2007). Application of S-shaped curves. ETRIA Conference TRIZ Future 2007. Frankfurt am Main, Germany.
- Kucharavy, D., R. De Guio, et al. (2007). Problem mapping for the assessment of technological barriers in the framework of innovative design. International Conference on Engineering Design, ICED'07, Paris, France.
- Lan, Z., P. B. Luh, et al. (1994). "Optimization-based inter-utility power purchases." IEEE Transactions on Power Systems 9(2): 891 - 897
- Makkonen, S. and R. Lahdelma (2006). "Non-convex power plant modeling in energy optimization." European Journal of Operational Research(171): 1113–1126
- Nayak, R. and J. D. Sharma (2000). "A hybrid neural network and simulated annealing approach to the unit commitment problem." Computers and Electrical Engineering(26): 461-477
- Paravan, D., H. Brand, et al. (2002). Optimization of CHP plants in a liberalised power-system. Balkan Power Conference, Belgrade.
- ProCom (2005). User manual: TEP Day Ahead Optimization Version 2.11. Aachen, ProCom GmbH.
- Richardson, G. and A. Pugh (1981). Introduction to System Dynamics Modeling. Waltham, Pegasus Communications, Inc.
- Roa-Sepulveda, C. A. and M. Herrera (2000). "A solution to the economic dispatch problem using decision trees." Electric Power Systems Research(56): 255-259
- Sage, A. P. e. and W. B. e. Rouse (1999). Handbook of Systems Engineering and Management, John Wiley & Sons.
- Salamatov, Y. (1991). System of evolution of technique laws. /Chance for adventure. Petrozavodsk, Karelia, Russia. (in Russian)
- Salamatov, Y. (1999). TRIZ: The right solution at the right time, Insytec B.V.
- Scheidt, M., T. Jung, et al. (2004). Integrated power station operation – BoFiT and Vattenfall Europe case study. The European electricity market EEM-04, Lodz, Poland, Politechnika Lodzka Instytut Elektroenergetyki.

- Scheidt, M. and H.-J. Sebastian (2001). Simulating day-ahead trading in electricity market with agents. The Second Asia-Pacific Conference of International Agent Technology (IAT-2001), Maebashi City, Japan.
- Scott Armstrong, J. (1983). Strategic Planning And Forecasting Fundamentals. The Strategic Management Handbook. A. e. Kenneth. New York, McGraw Hill: 2-1 to 2-32
- Senge, P. M. (1990). The Fifth Discipline: The Art & Practice of the Learning Organization. New York, Doubleday Currency.
- Song, Y. and X. Wang (2003). Operation of Market-Oriented Power Systems, Springer: 83-106
- Stock, G. and M. Henle (2002). "Virtuelle Kraftwerke, Optimierte Betriebsführung Integration »Virtueller Kraftwerke« in Querverbundsysteme." Euroheat & Power **31**(3): 58-63.(in German)
- Stone, P. and M. Veloso (2000). "Multiagent Systems: A Survey from a Machine Learning Perspective." Autonomous Robots(8): 345–383
- Sun, D., X. Ma, et al. (2005). The application of optimization technology for electricity market operation. 2005 IEEE/PES Transmission and Distribution Conference & Exhibition, Asia and Pacific Dalian, China.
- Tegeler, C. E-mail correspondence, From:te@procom.de, To:mateusz.slupinski@insa-strasbourg.fr.AW: technical questions. Sent on:Nov 21 2005 - 10:12am
- Thorin, E., H. Brand, et al. (2001). "Summary of specified general model for CHP system." (OSCOGEN Deliverable D1.4). OSCOGEN Deliverable D1.4, <http://www.oscogen.ethz.ch/>
- Wang, S. J., S. M. Shahidehpour, et al. (1995). "Short-term generation scheduling with transmission and environmental constraints using an augmented lagrangian relaxation." IEEE Transactions on Power Systems **10**(3)
- Wolstenholme, E. F. (2003). "Towards the definition and use of a core set of archetypal structures in system dynamics." System Dynamics Review **19**(1): 7-26
- Wood, A. J. and B. F. Wollenberg (1996). Power Generation Operation and Control. New York, John Wiley&Sons.
- Yamin, H. Y. (2004). "Review on methods of generation scheduling in electric power systems." Electric Power Systems Research(69): 227–248
- Yan, J. H. and G. A. Stern (2002). "Simultaneous Optimal Auction and Unit Commitment for Deregulated Electricity Markets." The electricity journal **15**(9): 72-80

---

# Appendix

---

Appendix 1. AIS – Analysis of initial situation

Appendix 2. SWOT (Strengths Weaknesses Opportunities Threats)

Appendix 3. Network of problems

---

## Appendix 1. AIS - Analysis of initial situation

---

Explanations:

**Algorithm** – internal part of the model, managing selected group of elements arranged to represent the reference case.

**Big** – referring to model/algorithm/MIP, it means the model/algorithm in current solution – current solution uses maximum set of data as a point of reference for the new solution.

**LP** – Linear Programming

**Marginal cost** – in economics and finance, marginal cost is the changes in total cost that arises when the quantity produced (or purchased) changes by one unit.

**Model** – it is an algorithm with applied data from the database.

**MIP** – Mixed Integer Programming

**Small** – referring to model/algorithm/MIP, indicating the new model/algorithm after solution's application, desired result.

The AIS was performed during the research at the stage when the problem was focused on the two objectives which have to be realized together in the successful production strategy. One is the optimization of the production strategy (PSt) for the technological system of energy production. Second is the optimization of the production strategy (PSt) considering the optimal configuration of the energy buy/sell contracts on the energy market.

### 1. By-pass approach

Imagine that the problem in principle can not be solved: it is impossible to deliver the robust model for 2 objectives mentioned above. The by-pass approach is to obtain the result without the model. The model is the structure to reflect and simplify the reality in order to solve the complex problem for the hypothetic conditions. If we learn how to examine our hypothesis (the production scenario) without the model, the model will be no longer needed.

The proposition of the by-pass can be also to make the calculation more reliable instead of making it faster as it is expressed in the initial problem.

## 1.1. Super-system

### Develop the static marginal cost

There is a gradient in the daily operation. One power plant runs stable, the other is changing to follow the variations in energy demand. The delay effect will occur. Delay has an influence on the marginal cost.

For GENCO it is desired to develop the static margin cost curve.

### Develop efficient energy storage for electricity

Efficient storage of the energy especially in the form of electricity or heat, will enable to suppress the delay, picks and mistakes in the daily schedule.

## 1.2. Sub-system

### Deliver better forecast

The best forecast decreases the risk. In this solution, technology data maintain the desired level of details. Result reports for traders will have longer permanence and lower trading risk. Therefore the model may be executed less often and there is no need to reduce the time of computation.

### Build a data record and generate various scenarios in advance

It is quite unrealistic, telling from the level of complexity of the model.

## 1.3. Opposite action

Opposite action – solution does not decrease time for the single computation cycle, but it increases it.

- It means that solution have to provide results with low risk, and then for majority of operations will require the result less often.
- Time for one computation cycle may rest unchanged, but model will provide results, which are valid for longer period.

Reminder – the main problem can not be solved – it is impossible to deliver the robust model for 2 objectives.

- The decrease in calculation time is not the point, the solution focuses on the low risk of data.

## 2. Which problem, original or by-pass, makes the most sense to solve?

By-pass proposed with the opposite action is not interesting for development. Lower risk should be provided anyway. The universal approach is already applied in the currently applied model.

In the sub-system, better forecast does not provide the shorter computation times. The risk of the results is decreased and the time step may be extended.

By-pass in the super-system:

- Application of the effective energy storage for electricity would solve the problem for daily operation, but it does not exist yet,
- development of static marginal cost would cause that any additional produced unit of energy will have the same price, therefore there will be no change in the price per unit of energy (MWh) in the market bid (market bid – price per unit and quantity) (Figure 62).



Figure 62. Marginal cost curve

- a. A typical Marginal Cost Curve
- b. Static Marginal Cost curve

It will be the best to find the solution to the original problem, where one model has to be customized for 2 objectives.



### 3. Use operator STC (Size, Time, Cost).

#### 3.1. Change dimension of the object gradually from given value to infinity.

Object: Model

Let's imagine that the database is 3 times as big as it used to be. The computation time increases with exponential relation. (Figure 63)

$$t_e = X^a$$

Figure 63. Time of optimization, exponential dependence

$t_e$  – time expense [s]

$X$  – number of parameters and constraints in the model

$a$  – increase in the number of parameters and constraints

e.g.: There are introduced twice as many parameters and constraints into the model.

$a=2$

$t_e = X^2$

Using the same algorithm, the number of computed scenarios decreases.

Necessary changes:

- time schedules reorganization
- reduce data's risk level – when the results are more certain it is valid for longer period

When we still increase the size of model, then it will be better to split the reference case into sub-models and calculate them separately, e.g. create an internal energy market, apply rules previously utilized to select the best scenario.

#### 3.2. Change dimension of the object from its giving value to zero.

Decrease of the model's size is the main goal. If the model is decreased very much, it will be possible to make it a part of the simulation program for traders. The model will be executed many times to find the best result. (This is under the conditions of the utilization of the scenarios analysis method, where the evaluation of higher number of results ameliorates the final result.)

(The objective is to satisfy both end-users of the model, then unless two of them are satisfied, it is not a solution to our problem.) The decreased model should not only serve the simulation for traders, but also take into account all technology parameters.

### 3.3. Changing the time of the process from its given value to infinity.

The time of computing increases. The only way to receive the acceptable result is to deliver correct forecasts and ensure reduced risk of data.

### 3.4. Changing the time of the process from its given value to zero.

See 3.2

### 3.5. Changing the cost (resources) from its given value to infinity.

We can multiply the computing units by  $X$ ,  $X \in \mathbb{N}$ , then in a one computing time we will receive  $X$  results for different scenarios.

### 3.6. Changing the cost (resources) from its given value to zero.

We can consider here the system and the nearest super-system, which includes data acquisition and human resources. We can use only what we already have, or we have to reduce resources. The algorithm should be changed to fulfill both objectives and additionally reduce the expense of the planning process. Except from the electricity to run the computing units, there is a cost of employment of energy experts. In order to reduce the cost it is necessary to replace energy experts with the modified decision making algorithm.

---

## Appendix 2. SWOT

---

## Appendix 2. SWOT

SWOT – Strengths, Weaknesses, Opportunities, Threats. The SWOT concept is used to evaluate the features of the analysis tools used in the construction of the method for analysis of the system of problem.

Table 18. SWOT analysis and comparison (Explanation of the acronyms: M-method, T-technique, column 1 indicates the symbol of the analysis tool in order to facilitate the reference)

1.	2.	3.	4.	5.	6.
	Analysis tool	Strengths (S)	Weaknesses (W)	Opportunities (O)	Threats (T)
A	M: AIS (Analysis of Initial Situation)	<ol style="list-style-type: none"> <li>1. It is an established method.</li> <li>2. It includes a described set of techniques.</li> <li>3. It deals with mental inertia.</li> <li>4. It stimulates to make description with quantitative characteristics.</li> <li>5. It analyses the life cycle.</li> </ol>	<ol style="list-style-type: none"> <li>1. Limited number of techniques</li> <li>2. Does not consider the evolution of the technical system.</li> <li>3. It does not systematize the output from the analysis.</li> </ol>	<ol style="list-style-type: none"> <li>1. Can be applied as a module, repeatedly for new problems, situations.</li> <li>2. It can be applied not necessarily at the beginning but also later in order to overcome the mental inertia at different stages of analysis.</li> <li>3. Some techniques can be more focused on.</li> </ol>	<ol style="list-style-type: none"> <li>1. Presentation of the output, could be more efficiently solved by the integration of the technique of presentation or organization of the thinking process.</li> <li>2. Other approach is adjusting to the situation by using larger set of techniques where some of them are applied and some are not, depending on the need.</li> </ol>
B	M: Method for the system exploration	<ol style="list-style-type: none"> <li>1. It is a method created for a need.</li> <li>2. It is based on laws of technical system evolution.</li> <li>3. It includes the organization of the thinking process.</li> </ol>	<ol style="list-style-type: none"> <li>1. It is assembled for individual situation.</li> <li>2. It requires good knowledge of the system elements.</li> </ol>	<ol style="list-style-type: none"> <li>1. It can be expanded with the application of other laws of technical system evolution.</li> <li>2. It can be applied for the prediction of the future development of the system.</li> </ol>	<ol style="list-style-type: none"> <li>1. Basic application may not return powerful results.</li> <li>2. Advanced analysis require development of the method.</li> </ol>
C	M: elements of ARIZ-85C	<ol style="list-style-type: none"> <li>1. It is element of the established algorithm for problem solving.</li> <li>2. It is based on easy to apply techniques.</li> <li>3. It helps in problem formulation, reformulation and intensification.</li> <li>4. It helps in preparation of good basis in problem definition and organization of thinking process.</li> </ol>	<ol style="list-style-type: none"> <li>1. It is a fragment of the larger method.</li> <li>2. It requires a training to apply.</li> </ol>	<ol style="list-style-type: none"> <li>1. It can be expanded if there is a need for deeper analysis.</li> <li>2. Techniques from the method can be used separately e.g. for organization of the thinking process.</li> </ol>	<ol style="list-style-type: none"> <li>1. Without training it may take more time to deliver the desired effect.</li> <li>2. It may require other elements of the ARIZ to boost the result.</li> </ol>

D	T: Pace of development in different parts of the system	<ol style="list-style-type: none"> <li>1. It links the analysis of different elements of the system.</li> <li>2. Gather the information about the solutions in the past.</li> <li>3. Introduces the measure of the development.</li> <li>4. Discloses irregularities in development.</li> </ol>	<ol style="list-style-type: none"> <li>1. It needs the organization of the analysis results.</li> <li>2. It requires the historical record on the development of the system's elements.</li> </ol>	<ol style="list-style-type: none"> <li>1. It helps to disclose the bottlenecks.</li> <li>2. It shows the elements which need development.</li> <li>3. It helps to battle the mental inertia.</li> </ol>	<ol style="list-style-type: none"> <li>1. It drives the attention away from the initial problem.</li> <li>2. It develops into the large separate analysis.</li> </ol>
E	T: Level of development analysis	<ol style="list-style-type: none"> <li>1. Stimulates the broader view on the organization of the system's elements.</li> <li>2. Uses the results of the tool D.</li> </ol>	<ol style="list-style-type: none"> <li>1. It needs the organization of the analysis results.</li> <li>2. It requires the historical record on the development of the system's elements.</li> </ol>	<ol style="list-style-type: none"> <li>1. Offers the alternative approach to the analysis of the system's elements.</li> <li>2. Supports the construction of the evolution chart.</li> </ol>	<ol style="list-style-type: none"> <li>1. It generates many data which unorganized may be not used efficiently.</li> <li>2. The wrong construction of the evaluation parameters leads to wrong conclusions</li> </ol>
F	T: Harmonization analysis	<ol style="list-style-type: none"> <li>1. Links the different elements of the system.</li> <li>2. Supports the view of the 'big picture'.</li> <li>3. Stimulates the utilization of the measurable parameter.</li> <li>4. Underlines the interrelations in the system.</li> </ol>	<ol style="list-style-type: none"> <li>1. Need to define the measurable parameter of harmonization.</li> <li>2. It is necessary to define which pair or group of elements have to be harmonized.</li> </ol>	<ol style="list-style-type: none"> <li>1. Increase in the performance of the existing solution.</li> <li>2. Offers the alternative approach to the analysis of the system's elements.</li> </ol>	<ol style="list-style-type: none"> <li>1. It generates many data which unorganized may be not used efficiently.</li> <li>2. It discloses new problems which have to be described.</li> </ol>
G	T: Energy flow analysis	<ol style="list-style-type: none"> <li>1. Links the different elements of the system.</li> <li>2. Focuses on the energy flow.</li> <li>3. Applies the fixed model of the energy flow diagram.</li> <li>4. It allocates the certain role to the elements of the system e.g. control, engine.</li> </ol>	<ol style="list-style-type: none"> <li>1. The one analysis has to consider single flow of energy.</li> <li>2. The user decides on the integration of this technique into a method of analysis.</li> </ol>	<ol style="list-style-type: none"> <li>1. It can be applied repeatedly on the different scale of the system.</li> <li>2. It stimulates to describe larger set of system's elements.</li> </ol>	<ol style="list-style-type: none"> <li>1. The concept of the energy flow can be misinterpreted.</li> <li>2. The energy flow is often associated strictly with the technology process.</li> </ol>
H	T: Construction of the Multi Screen Scheme of thinking	<ol style="list-style-type: none"> <li>1. Organizes the thinking process.</li> <li>2. Drives the thinking about the analysis process.</li> <li>3. It is constructed independently from other analysis processes.</li> </ol>	<ol style="list-style-type: none"> <li>1. It does not provide an easy to read representation of the analyzed system.</li> <li>2. It does not support the representation of the feedback loops.</li> </ol>	<ol style="list-style-type: none"> <li>1. It can be used in connection with the tools representing the system using different concept.</li> <li>2. It can be constructed in parallel with the process of system analysis.</li> <li>3. It suggests the direction in the analysis with different tools.</li> </ol>	<ol style="list-style-type: none"> <li>1. It will not substitute the system demonstration tools.</li> <li>2. The scheme is entirely readable for the user, it is individualized way of representation of the thinking process.</li> </ol>

I	T: By-pass analysis	<ol style="list-style-type: none"> <li>1. It expresses the by-pass tendency in the form of analysis.</li> <li>2. Describes the problem situation and the outside constraints.</li> </ol>	<ol style="list-style-type: none"> <li>1. Description of the by-pass is a concept.</li> <li>2. Requires additional description of elements used in the by-pass proposition.</li> </ol>	<ol style="list-style-type: none"> <li>1. Helps to overcome the mental inertia.</li> <li>2. It may be an impulse to the analysis of the problem which solved by the proposed by-pass.</li> </ol>	<ol style="list-style-type: none"> <li>1. It may drive the analysis to the region which was excluded due to the lack of resources.</li> <li>2. It requires the support of the other tools in order to do it in the systematic way.</li> </ol>
J	T: Size Time Cost (STC) operator application	<ol style="list-style-type: none"> <li>1. Helps to overcome the mental inertia.</li> <li>2. Generates the solution propositions.</li> </ol>	<ol style="list-style-type: none"> <li>1. It requires the wise way to capture the results from the analysis.</li> <li>2. Relation between the increased/decreased value and the real system</li> </ol>	<ol style="list-style-type: none"> <li>1. It may begin the new thread in the research following the one of the factors: size, time or cost.</li> <li>2. It may propose the solution for similar problem or for some particular situation conditions different from considered in the analysis.</li> </ol>	<ol style="list-style-type: none"> <li>1. The analysis will help to overcome the mental inertia but the results from the analysis will be lost.</li> <li>2. The solution in the increased/decreased scale should be transformed back to the particular situation conditions.</li> </ol>
K	T: Analysis of life time cycle	<ol style="list-style-type: none"> <li>1. Helps to gather the information about the system.</li> <li>2. Underlines the interrelations in the system.</li> <li>3. Gather information on the larger time scale.</li> </ol>	<ol style="list-style-type: none"> <li>1. Requires additional data about the design and disposal stages.</li> <li>2. In case of long lasting cycle late stages are based on the current knowledge.</li> </ol>	<ol style="list-style-type: none"> <li>1. It can be applied repeatedly on the different scale of the system.</li> <li>2. Provide the indications to form the sustainable features of the system.</li> <li>3. The state of the system at other stages may show the next bottleneck in the system.</li> </ol>	<ol style="list-style-type: none"> <li>1. Frequently repeating life cycle undergoes also the evolution.</li> <li>2. The analysis of the life cycle should also refer to the sub-components.</li> </ol>
L	T: Problem redefinition	<ol style="list-style-type: none"> <li>1. Helps in redefinition of the research area.</li> <li>2. Intensifies the problem.</li> </ol>	<ol style="list-style-type: none"> <li>1. It is repeated utilization of the same model for the problem definition.</li> <li>2. Necessary to keep in mind the principle of intensification</li> </ol>	<ol style="list-style-type: none"> <li>1. Increase the understanding of the problem.</li> <li>2. Discovers the conditions describing the problem necessary to intensify its definition.</li> </ol>	<ol style="list-style-type: none"> <li>1. It requires additional tools to support the problem intensification e.g. tool A.</li> <li>2. The problem may be redefined but not intensified.</li> </ol>
M	T: Step back analysis	<ol style="list-style-type: none"> <li>1. Discloses the problem which was solved by the solution applied in the system or in a similar system.</li> <li>2. Solution used in the other system may have the same problem at the origin as our system.</li> </ol>	<ol style="list-style-type: none"> <li>1. It requires the already existing solution to start with.</li> <li>2. The description of the original problem is not clear basing on present description.</li> <li>3. The original problem may have been described for the particular problem conditions which are not clear.</li> </ol>	<ol style="list-style-type: none"> <li>1. The solution to the problem in the origin to an existing partial solution may be more powerful for current problem.</li> <li>2. It is possible to learn the approach to the problem solving in the past, identify the major problem and address it with new data.</li> </ol>	<ol style="list-style-type: none"> <li>1. It may lead to very general problems.</li> <li>2. The root problem may be very particular and not applicable to our case.</li> </ol>

N	T: Construction of the network of problems	<ol style="list-style-type: none"> <li>1. Underlines the interrelations in the system.</li> <li>2. Supports the view of the 'big picture'.</li> <li>3. It links the analysis of different elements of the system.</li> <li>4. It is possible to build it in parallel to the collection of the data about the system.</li> </ol>	<ol style="list-style-type: none"> <li>1. For the presentation, focus on particular region.</li> <li>2. The identification of the problems depends on the user or the group of experts.</li> </ol>	<ol style="list-style-type: none"> <li>1. It helps in the construction of the network of contradictions.</li> <li>2. It builds the map of the knowledge about the system.</li> <li>3. It drives the analysis, give directions where to apply the analysis tools in order to describe the further elements.</li> </ol>	<ol style="list-style-type: none"> <li>1. It may become individualized by the user.</li> <li>2. The number of elements and links requires organization in regions.</li> </ol>
O	T: Construction of the network of contradictions	<ol style="list-style-type: none"> <li>1. Supports the view of the 'big picture'.</li> <li>2. Contradictions are united under the common objectives.</li> </ol>	<ol style="list-style-type: none"> <li>1. There is a need to choose properly the key problems.</li> <li>2. Operation of the network of contradictions does not have clear rules.</li> <li>3. Construction of the network is based on the individual technique.</li> </ol>	<ol style="list-style-type: none"> <li>1. Selection of the key contradiction.</li> <li>2. Direct support for the problem solving in the complex system.</li> <li>3. Relation with the key problems in the network of problems.</li> <li>4. Organization and management of the knowledge.</li> </ol>	<ol style="list-style-type: none"> <li>1. Operation of the network requires good knowledge of all stages of its creation.</li> <li>2. Selection of the key contradiction may lead to re-think of the construction of the network of contradictions.</li> </ol>
P	T: Construction of the IDEFØ graph	<ol style="list-style-type: none"> <li>1. Links the different elements of the system.</li> <li>2. Supports the view of the 'big picture'.</li> <li>3. It links the analysis of different elements of the system.</li> <li>4. Presents the feedback loops.</li> </ol>	<ol style="list-style-type: none"> <li>1. Construction of the diagram is restricted by many rules.</li> <li>2. Size of the diagram presented on one page is limited.</li> <li>3. It does not support the presentation of the process sequence.</li> </ol>	<ol style="list-style-type: none"> <li>1. It serves as a presentation tool.</li> <li>2. It improves the understanding of the system.</li> </ol>	<ol style="list-style-type: none"> <li>1. The diagram may become understandable only for the experts in the domain or people who participated in the creation process.</li> <li>2. It requires the written explanation.</li> </ol>
R	T: Construction of the Causal Loop Diagram (CLD)	<ol style="list-style-type: none"> <li>1. Underlines the interrelations in the system.</li> <li>2. Links the different elements of the system.</li> <li>3. Supports the view of the 'big picture'.</li> <li>4. Presents the feedback loops.</li> <li>5. Size of the diagram is not limited.</li> </ol>	<ol style="list-style-type: none"> <li>1. Large diagrams become difficult to read.</li> <li>2. Variables need to be carefully named.</li> </ol>	<ol style="list-style-type: none"> <li>1. It helps in the construction of the stock and flow diagrams.</li> <li>2. It is possible to derive the archetypes of the solutions to the analyzed problem. (Wolstenholme 2003)</li> <li>3. It is possible to individualize the CLD for the particular situation by addition of new variables.</li> </ol>	<ol style="list-style-type: none"> <li>1. The key problem is not directly visible.</li> <li>2. The structure is not truly dynamic.</li> </ol>

S	T: Construction of the stock and flow diagram	<ol style="list-style-type: none"> <li>1. Underlines the interrelations in the system.</li> <li>2. Links the different elements of the system.</li> <li>3. Supports the view of the 'big picture'.</li> <li>4. Presents the feedback loops.</li> <li>5. It is possible to identify leverage points and synergy effect.</li> </ol>	<ol style="list-style-type: none"> <li>1. There is a need to recognize flows and stocks in the CLD diagrams built at the first stage.</li> <li>2. It requires to describe the relations by the means of equations.</li> <li>3. Identification of positive and negative relations in flows.</li> </ol>	<ol style="list-style-type: none"> <li>1. It provides the system modeling function.</li> <li>2. It shows the dynamic operation of the system.</li> </ol>	<ol style="list-style-type: none"> <li>1. The stability may be fragile.</li> <li>2. Identification of the leverage points and synergy requires experimentation.</li> </ol>
---	---	---	---	--	--





---

## Appendix 3. Network of problems

---

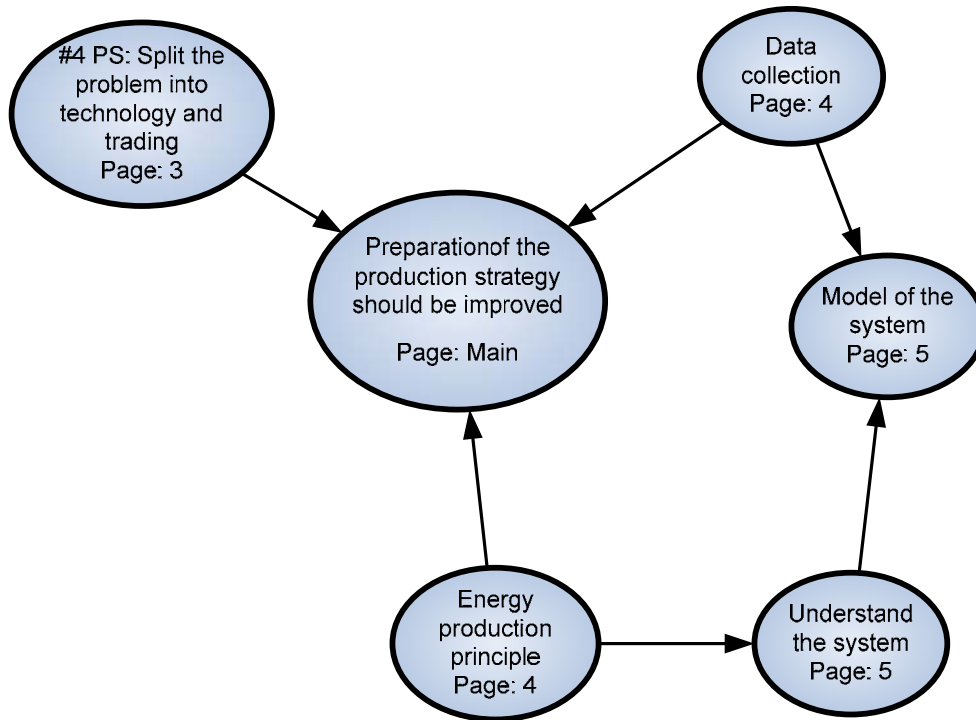

Figure 64. Network of problems - map

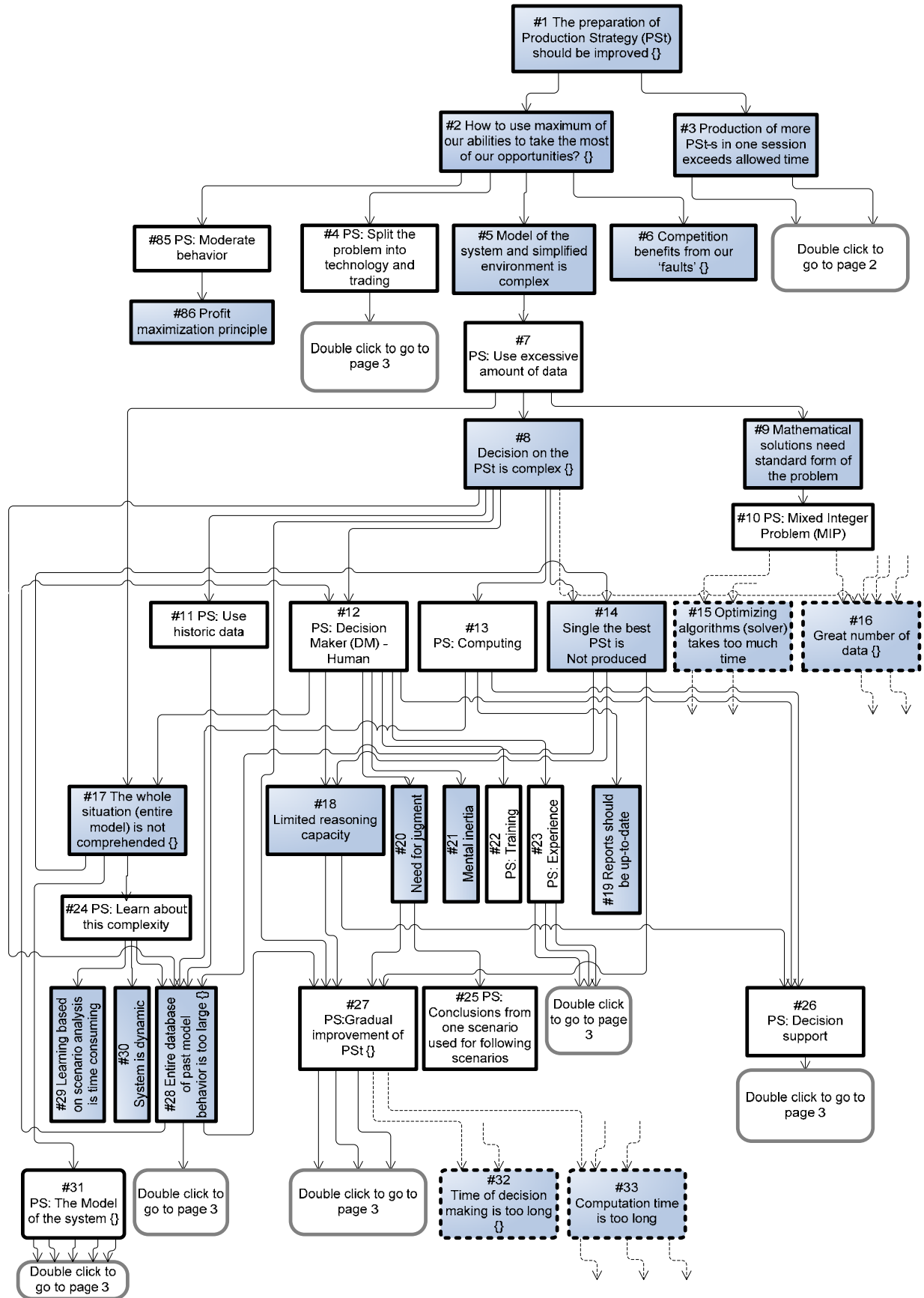

Figure 65. Network of problems – page ‘Main’

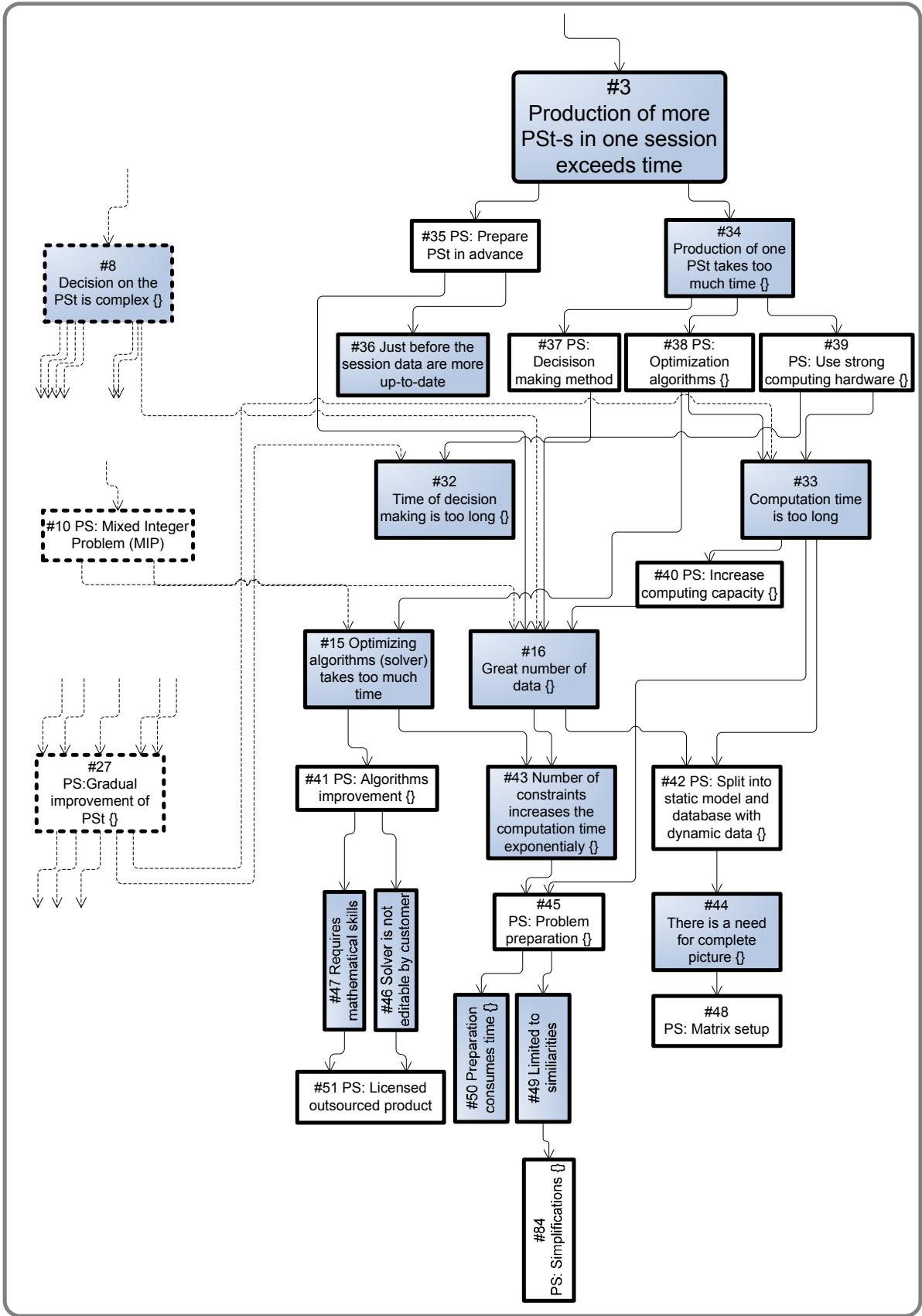

Figure 66. Network of problems; Page 2

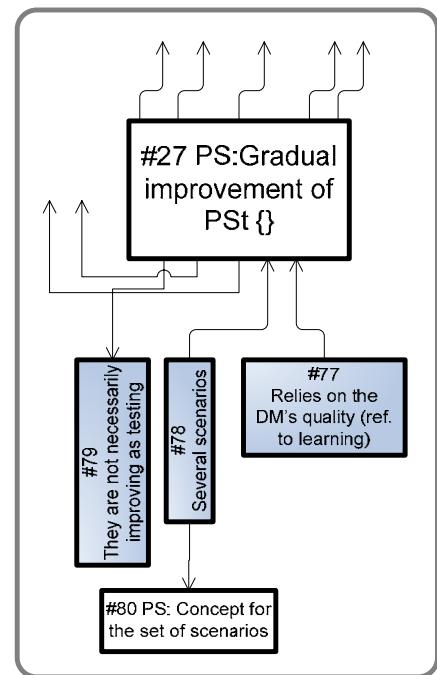
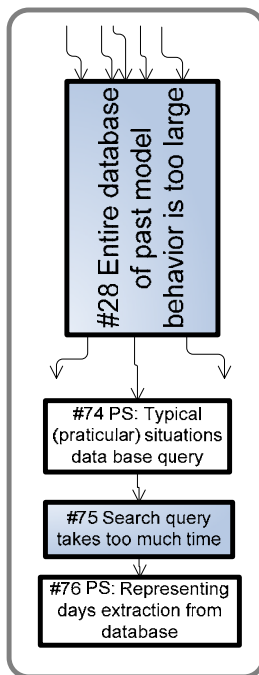
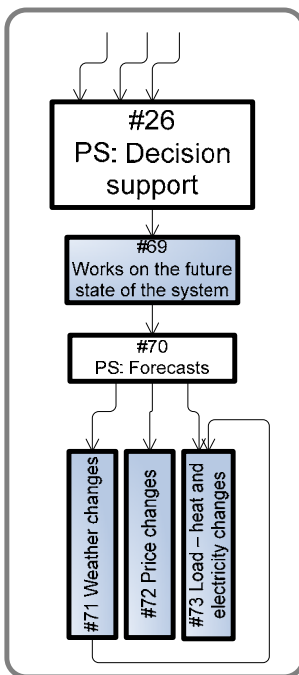
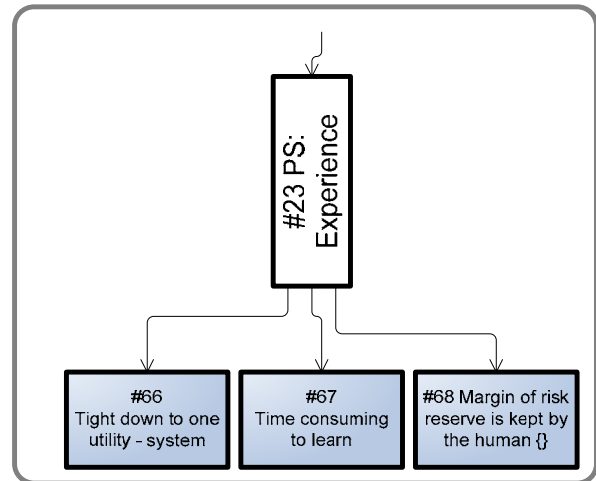
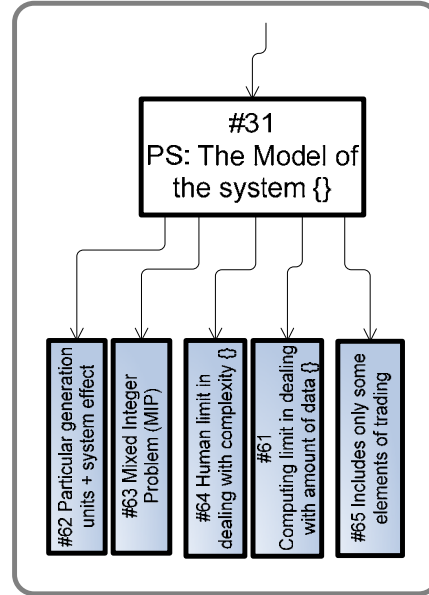
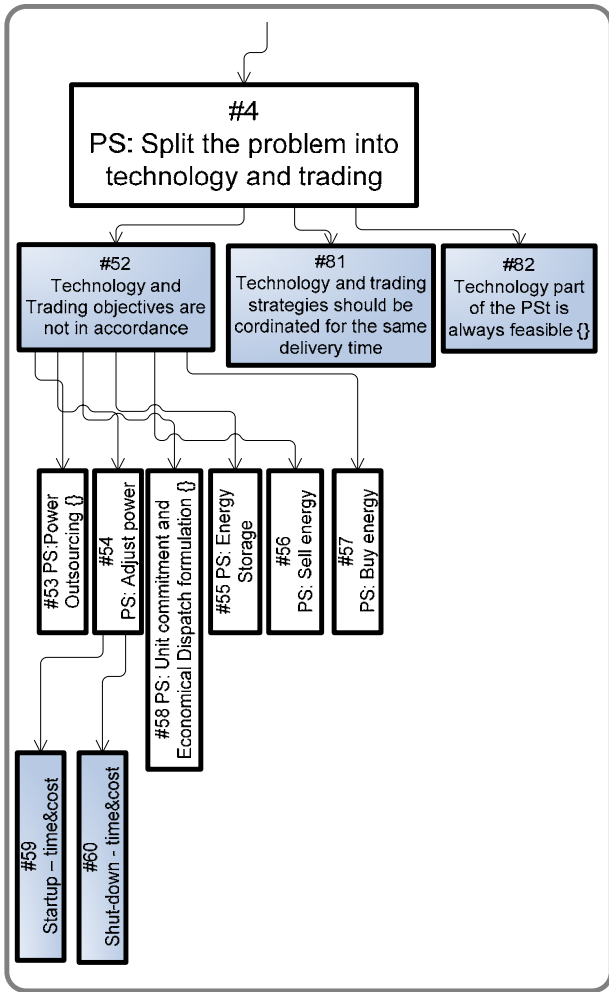

Figure 67. Network of problems; Page 3

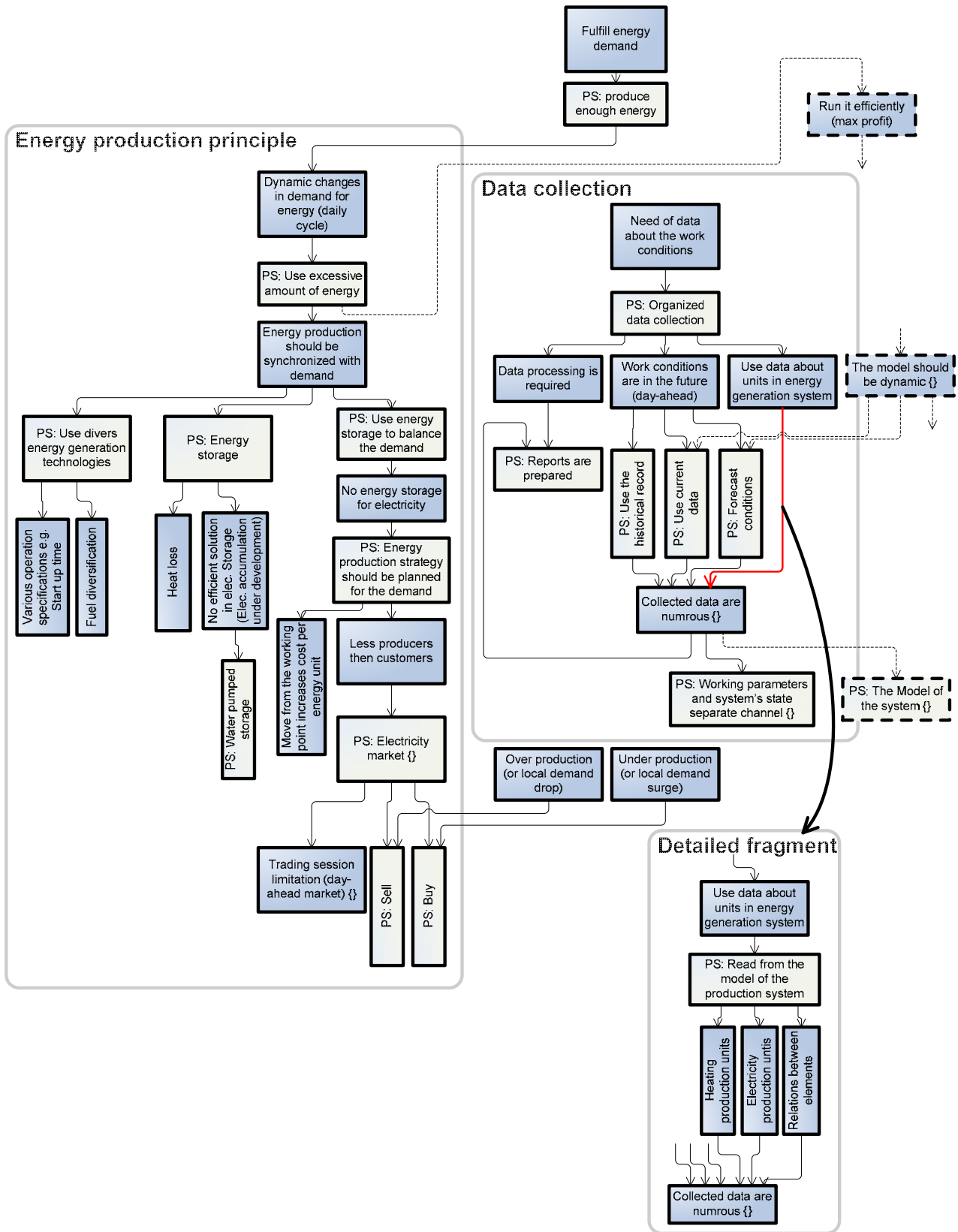

Figure 68. Network of problems; Page 4

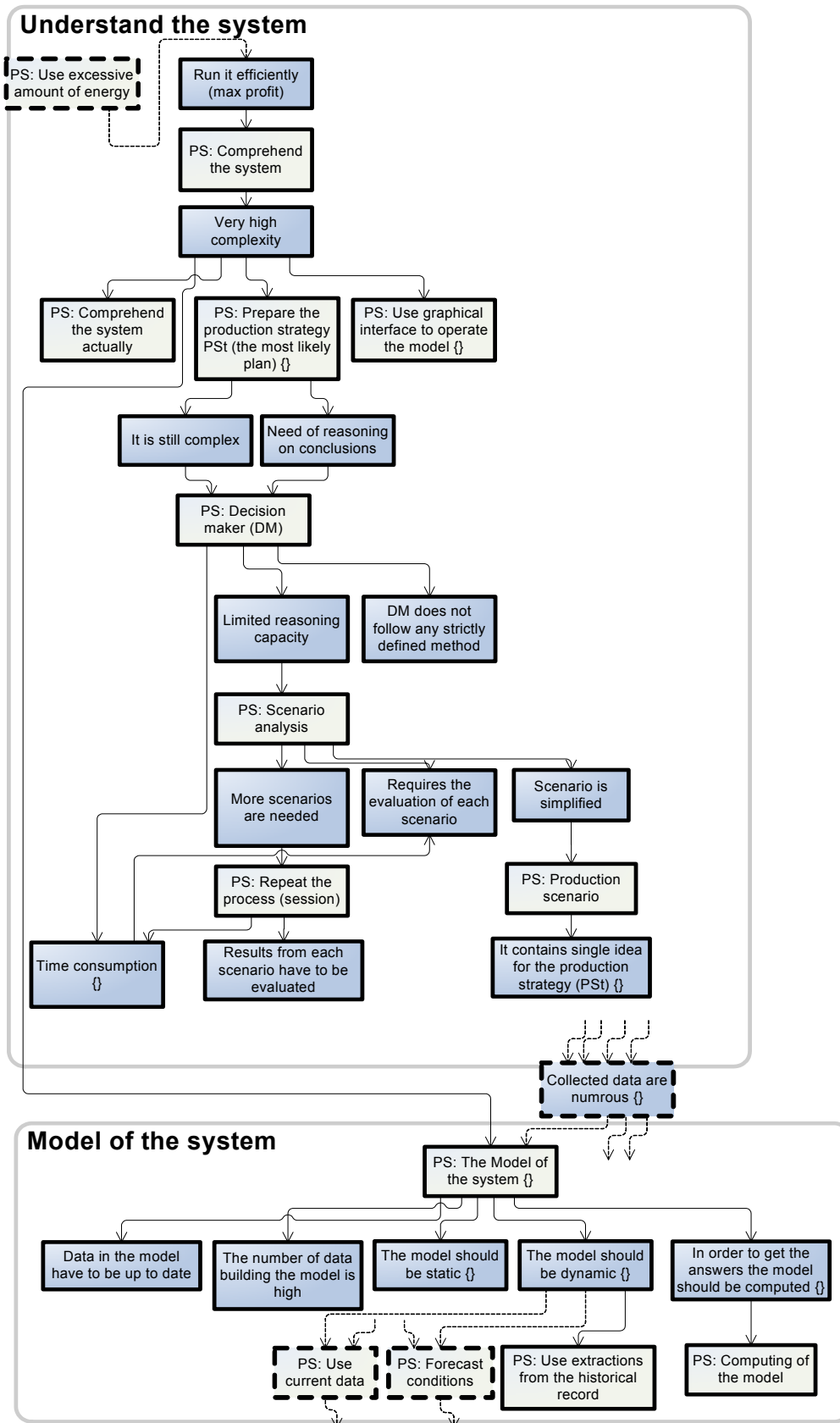

Figure 69. Network of problems; Page 5